



ELECTRIC SERVICE STANDARDS



2021 EDITION

TO OBTAIN LOCATION OF UNDERGROUND GAS AND ELECTRIC LINES

Before DIGGING call: 1(800) Dig Test or 811 "One Call"

TO REPORT DAMAGE TO UNDERGROUND GAS AND ELECTRIC LINES

Telephone: (210) 353-HELP (4357)

Toll Free: (800) 870-1006

TDD for Hearing-Impaired Customers: (210) 353-2224

TO REPORT DAMAGE TO OVERHEAD ELECTRIC LINES

Telephone: (210) 353-HELP (4357)

Toll Free: (800) 870-1006

TDD for Hearing-Impaired Customers: (210) 353-2224

TO REPORT TREE TRIMMING AROUND POWER LINES

Telephone: (210) 353-2222

TO REPORT GAS OR ELECTRIC TROUBLE, ALL HOURS

Telephone: (210) 353-HELP (4357)

Toll Free: (800) 870-1006

TDD for Hearing-Impaired Customers: (210) 353-2224

WHEN PLANNING NEW CONSTRUCTION, SERVICE, AND METER INSTALLATIONS

Telephone: (210) 353-4050

TDD for Hearing-Impaired Customers: (210) 353-2224

WHEN PLANNING UPGRADES, OR CHANGE POSITIONS FOR EXISTING SERVICES ABOVE 300 kVA (INDUSTRIAL, LARGE COMMERCIAL, MULTI-FAMILY)

Telephone: (210) 353-4050; Email: LargeCommercial-CE@CPSEnergy.com

WHEN PLANNING UPGRADES, CHANGE POSITIONS, OR REROUTES FOR EXISTING SERVICES BELOW 300 kVA (SMALL COMMERCIAL, RESIDENTIAL)

Telephone: (210) 353-4975; Email: CPSEWW@CPSEnergy.com

WHEN PLANNING INSTALLATION OF DISTRIBUTED GENERATION (DG)

Telephone: (210) 353-2700 or website at www.cpsenergy.com, *Simply search for "Distributed Generation"*.

TO ORDER METER SOCKETS AND/OR METER ENCLOSURES

Telephone: (210) 353-2734

Equipment Pickup at 511 S. Salado Street. (210) 353-4245

ATTACHING ANY UTILITY FACILITIES OR BANNERS TO UTILITY/STREETLIGHT POLES

An online version of the "Pole Attachment Standards" is available at www.cpsenergy.com. Simply search for "Pole Attachment Standards".

TO REQUEST CPS ENERGY INSPECTIONS ON TRANSFORMER SLABS AND DUCTLINE INSTALLATIONS

Call CPS Energy Customer Service Representative whose name and telephone number is on the CPS Energy Job Sketch, or call (210) 353-3373 (24-hour notice required).

NOTE: An online version of the "Electric Service Standards" is available at www.cpsenergy.com. Simply search for "Electric Service Standards".

CPS ENERGY SERVICE BOUNDARY LINES

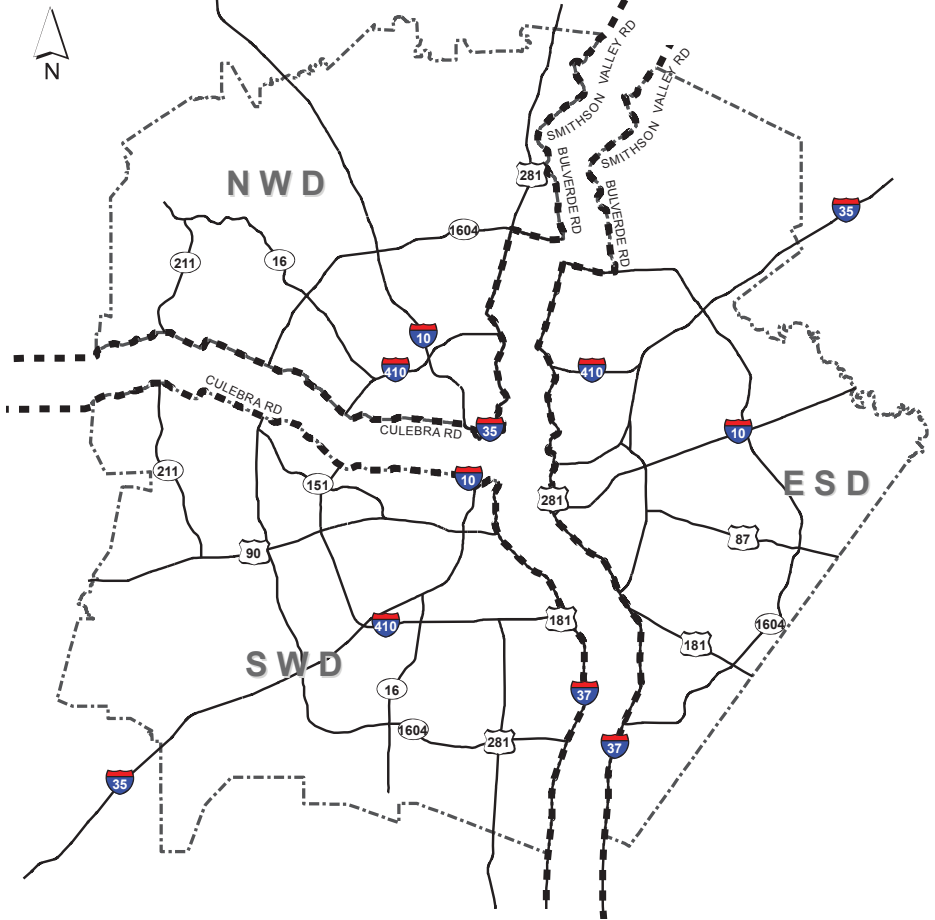



INTRODUCTION TO ELECTRIC SERVICE STANDARDS

The 2021 edition of CPS Energy's Electric Service Standards presents for the convenience of Electrical Contractors, Architects, Engineers, and others, the current standards and requirements for electric service and meter installations. It supersedes all previous editions of the Electric Service Standards.

These service standards are intended to supplement the City of San Antonio Electrical Code, National Electrical Code, and National Electrical Safety Code, and to establish certain requirements that are based on experience for maintaining safe and reliable service for CPS Energy Customers. This book of standards does not attempt to cover in detail all the various situations that might be encountered with the numerous combinations possible in the construction of electric service installations. The illustrations are of a general nature to show the more important features in construction. Where conditions arise that are not covered in this book, the Customer is requested to contact a CPS Energy Customer Service Representative to discuss the particular installation.

By providing these service standards, CPS Energy and Electrical Contractors, Architects, and Engineers can continue to work cooperatively to complete service installations in a safe and proper manner in order to provide electric service and metering installations for our mutual Customers with the highest degree of user satisfaction.

REVISIONS TABLE

CPS ENERGY ELECTRIC SERVICE STANDARDS REVISIONS – 2021 EDITION

The revisions table included herewith is comprised of only major revisions in the 2021 edition of the CPS Energy Electric Service Standards. Minor changes include text rewording, grammatical revisions, spellings, and corporate name changes which are not included or considered noteworthy.

<u>SECTION</u>	<u>TITLE</u>	<u>REVISION SUMMARY</u>
SECTION 70	SAFETY	No changes to this section.
SECTION 80	SUPPLY AND UTILIZATION FACILITIES	No changes to this section.
SECTION 90	GENERAL INFORMATION	Connected load changed to calculated load. Distributed Energy Resource (DER) changed to Distributed Generation (DG). Article 90.4.2 – Note added regarding when instrument transformer rated metering equipment will be required.
SECTION 100	DEFINITIONS	Revised Definitions: Connected Load changed to Calculated Load, Distributed Energy Resources (DER) changed to Distributed Generation (DG), Grid-Tied Disconnect, Interconnection Facilities, Meter Disconnect Switch, Point of Common Coupling, Point of Interconnection, Service Raceway.
SECTION 200	CHARACTERISTICS, TYPES AND AVAILABILITY OF ELECTRIC SERVICE	Basic formatting and language clarification of existing rules. Article 203.6 – New language added regarding service supplied by multiple transformers, including transformers required for load capacity and redundancy. Article 208 – New language added regarding separately platted properties and property lines.
SECTION 300	USE OF ELECTRIC SERVICE	Article 304.3 – New language added regarding motors greater than 100-horsepower. Article 306.2 – Changed to Interconnected Distributed Generation. New language added regarding net metered DG Facilities and grid tied DG Facilities.

REVISIONS TABLE

<p>SECTION 400</p>	<p>SERVICE EQUIPMENT</p>	<p>Article 402 - Note added regarding feeder and branch circuits in gutters or wireways containing service-entrance conductors. New Article 403.8 - Equipment Connected to Supply-Side of Service Disconnect. Article 404 - Means of Identifying Grounded and Ungrounded Conductors moved from Article 509.7 and Article 509.8. Numbering of Articles changed respectively. Article 407.1 - Note added regarding grouping of fire pump meter with other metering equipment. Article 408.1 - Language added regarding short-circuit rating of meter disconnect. Article 408 - Changed to Article 409 Meter Disconnects for Distributed Generation (DG).</p>
<p>SECTION 500</p>	<p>OVERHEAD SERVICES (SERVICE DROPS UNDER 600 VOLTS)</p>	<p>Basic formatting and language clarification of existing rules. Article 506.4 - Exception removed and language added regarding paralleling service-entrance conductors in a single conduit. Article 509.7 - Means of Identifying Grounded Conductors and article 509.8 Means of Identifying Ungrounded Conductors moved to Article 404. Numbering of Articles changed as a result respectively. Article 509 - Changed to Article 510 and note added regarding service disconnecting means. New Figure 500.9 added to show two or more meters served from one gutter. New Figure 500.10 added to show a 320-amp meter socket supplying a gutter.</p>
<p>SECTION 600</p>	<p>OVERHEAD TO UNDERGROUND SECONDARY SERVICE</p>	<p>Basic formatting and language clarification of existing rules. Article 603 - Note and exception removed. Article 604.1 - Revised to clarify conduit type for above and below ground service lateral. Article 604.2 - Exception added regarding minimum elbow radius on residential installations.</p>

REVISIONS TABLE

SECTION 600	OVERHEAD TO UNDERGROUND SECONDARY SERVICE	Figure 600.1 - Revised to show Customer installing 10-ft length metal conduit riser. New Figure 600.2 added to show an underground multi-meter installation served from overhead facilities. Numbering of Articles changed respectively.
SECTION 700	UNDERGROUND RESIDENTIAL DISTRIBUTION (URD) SERVICE	New Figure 700.2 - Added to show an underground residential distribution servicing two meters.
SECTION 800	UNDERGROUND SERVICE IN APARTMENT COMPLEXES	Basic formatting and language clarification of existing rules. Article 805.2 (D)- Changed to Junction/Pull Box (Underground Installations). Figure 800.1 - Revised to better depict typical electric distribution for an apartment complex. Figure 800.2 - Revised to reflect updated information.
SECTION 900	SERVICE IN HIGH-RISE RESIDENTIAL BUILDINGS	New Article 904.1 - Meter Room Disconnecting Means (Device). New Article 904.2 - Metering Equipment.
SECTION 1000	COMMERCIAL OR INDUSTRIAL SERVICES FROM PADMOUNT TRANSFORMERS	Basic formatting and language clarification of existing rules. Article 1002.4 - Specified cable lug and tap box specifications. Article 1002.6 - Note added regarding conduit type for metering control cable. Figure 1000.1 - Revised to better depict Customer service-entrance lateral. Figure 1000.2 - Revised to indicate clearance in front of padmount transformer.
SECTION 1100	SERVICE FROM DOWNTOWN NETWORK SYSTEM	Basic formatting and language clarification of existing rules. Article 1102.1 - Note added regarding PVC type for service lateral conduits. Article 1102.2 - Revised to clarify party responsible for furnishing and installing grid-tied disconnect along with proper fuses. Article 1103.2 - Specified cable lug specifications and new language added regarding conductors on the load-side of fuse pad.

REVISIONS TABLE

SECTION 1200	COMMERCIAL SERVICES FROM SINGLE-PHASE UNDERGROUND RESIDENTIAL DISTRIBUTION PADMOUNT TRANSFORMERS	Incorporated Section 1200 Primary Voltage Service Overhead into Section 1300 Added New Type of Service that would permit a Commercial Facility to be Served from a Single-Phase URD transformer.
SECTION 1300	PRIMARY VOLTAGE SERVICE	Incorporated Primary Voltage Service - Overhead and Underground into Section 1300. Basic formatting and language clarification of existing rules. Article 1302 - New language added to note regarding the point of delivery. Article 1303 - Changed to CPS Energy Primary Voltage Overhead or Underground. Article 1303 covers Overhead Voltage Service and Article 1304 covers Underground Voltage Service. Article 1304.1 Clarifies Ductline and Primary Voltage Cable and language to better depict existing rules. Article 1304.3 - Clarified language to better depict existing rules.
SECTION 1400	SERVICE TO CUSTOMER OWNED METER POLE	Article 1405 - Language added regarding telecommunication systems. Exception added for telecommunication systems in accordance with Section 1900. Figure 1400.1 - Revised to reflect updated information.
SECTION 1500	SERVICE IN MANUFACTURED HOME COMMUNITIES	Article 1502 - Note added to reflect that only single meter pedestals will be permitted. Article 1503 - Note added to clarify requirements for overhead to underground services. Figure 1500.1 - Revised to reflect updated information.
SECTION 1600	TEMPORARY SERVICE	Basic formatting and language clarification of existing rules. Article 1602 - Note added regarding temporary three-phase overhead services. Figure 1600.2 - Revised to reflect updated information regarding three-phase temporary services.
SECTION 1700	GROUNDING OF SERVICES	No changes to this section.
SECTION 1800	METERING EQUIPMENT AND ITS INSTALLATION	Basic formatting and language clarification of existing rules.

REVISIONS TABLE

<p>SECTION 1800</p>	<p>METERING EQUIPMENT AND ITS INSTALLATION</p>	<p>Article 1801.2 - Language added regarding securing of unmetereed conductors.</p> <p>Article 1802.2 - Condensed to remove information needed only for specific installations.</p> <p>Article 1802.4 - Updated metering equipment pickup location.</p> <p>Article 1803 - Language added regarding metering equipment furnished by CPS Energy and/or Customer.</p> <p>Article 1803.1 - Language added regarding conductor size limitations and parallel conductors in individual raceways.</p> <p>Article 1803.2 - Note added regarding Customer furnished metering enclosures. Language added regarding transocket sizing standards, connectors installed on the load-side of CT's on overhead to underground services, location of instrument transformers on overhead service drops, self-contained metering sockets used to measure services supplied by 300 kVA or less transformers, code 12 CT enclosure installation above an auxiliary gutter.</p> <p>Article 1804.1 - Notes added regarding wiring of single-phase, self-contained meter sockets and CPS Energy furnished metering equipment.</p> <p>Article 1804.2 - Language added regarding house loads exceeding 200 amperes served from modular metering equipment.</p> <p>Article 1804.3 - Language added regarding more than one-meter socket per pedestal.</p> <p>Article 1804.4 - Note added regarding service drops supported by stand-alone meter racks.</p> <p>Article 1804.5 - Language added regarding neutral passing through meter compartment ground bonding terminal in meter compartment.</p> <p>Article 1805.1 - Expanded upon prohibited locations of metering equipment.</p> <p>Article 1806 - Language revised regarding heights of modular metering equipment.</p>
----------------------------	--	--

REVISIONS TABLE

<p>SECTION 1800</p>	<p>METERING EQUIPMENT AND ITS INSTALLATION</p>	<p>Article 1807.5 - Language added regarding clearances from CPS Energy gas regulator. New Article 1807.6 - Clearance from Receptacles. Article 1808.1 - Language added regarding house loads exceeding 200 amperes. Article 1808.2 - Clarification regarding termination of conductors onto bus in bussed gutter. Language added regarding bus gutters rated 600 Amps or less. Note added regarding the ganging or extending of bussed gutters. Article 1808.3 - Language added regarding wire gutter dimensions for meters grouped with an auxiliary wire gutter and termination of service lateral conductors in Customer furnished and installed junction box. Lettering of articles changed, respectively. Article 1808.3 (B) Changed to Article 1808.3 (C) Underground Installations (Junction/Pull Box). New Article 1808.4 - Adding Meters for Fire Pumps. Numbering of Articles changed, respectively. Article 1808.6 - Language added to include the two installation options for cell tower site services. Table 1800.1 - Revised to include code 32 320-amp meter socket. Table 1800.2 - Revised to show Code 32 320 Amp meter sockets and associated minimum and maximum calculated loads. Figure 1800.1 - Code 03 320 Amp meter socket removed. Updated allowable conductors for Code 31, 320 Amps meter socket. Figure 1800.2 - Code 32, 320 Amp meter socket added. New Figure 1800.7 added to show meter socket wiring for 320 Amp three-phase 208Y/120-volt, 4-wire service. Numbering of figures changed, respectively. New Figure 1800.9 added to show meter socket wiring for 200 Amp three-phase, 480Y/277-Volt, 4-wire service. Numbering of figures changed, respectively.</p>
----------------------------	--	---

REVISIONS TABLE

<p>SECTION 1800</p>	<p>METERING EQUIPMENT AND ITS INSTALLATION</p>	<p>New Figure 1800.10 added to show meter socket wiring for 320 Amp three-phase, 480Y/277-volt, 4-wire service. Numbering of figures changed, respectively. Figure 1800.14 - Revised to reflect updated information. Figure 1800.19 - Changed to Figure 1800.21. Revised to better reflect gas service equipment clearances.</p>
<p>SECTION 1900</p>	<p>CELL TOWER SITE AND WIRELESS COMMUNICATION SYSTEM</p>	<p>Article 1901 - Language added to include wireless and communication systems. Article 1902 - Changed to New Service for Cell Tower Sites. New Article 1904 - New Service Installations for Wireless Communication Services. Numbering of Articles changed respectively. Article 1904 - Changed to Article 1905. Language added regarding meter pedestal equipment specifications. New Figure 1900.2 - Added to show underground service, self-contained meter pedestal for wireless communication system. New Figure 1900.3 - Added to show overhead service for wireless communication system facing the sidewalk. New Figure 1900.4 - Added to show overhead service for wireless communication system facing the sidewalk and traffic. New Figure 1900.5 - Added to show underground service for wireless communication system. New Figure 1900.6 - Added to show underground service, self-contained meter(s) for wireless communication systems.</p>
<p>SECTION 2000</p>	<p>DISTRIBUTED GENERATION (DG)</p>	<p>Distributed Energy Resources (DER) changed to Distributed Generation (DG). Basic formatting and language clarification of existing rules. Article 2002 - Language added to include additional types of DG Facilities. New Article 2003 - Downtown Network System Interconnection of DG.</p>

REVISIONS TABLE

<p>SECTION 2000</p>	<p>DISTRIBUTED GENERATION</p>	<p>Numbering of Figures Changed, respectively. Article 2003 - Changed to Article 2004 CPS Energy Facilities and System Modifications. Article 2005.2 - Article 2010 Solar Power (Photovoltaic) General relocated to Article 2005.2 Design Considerations of DG Facilities. Note added regarding disconnect to isolate PV meter when interconnection is made at a remote location. Language added regarding load-side and line-side interconnections, rapid shutdown of DG Systems, grounding of DG Systems, and PV conductors in attic spaces. New Figure 2000.1 - Added to show a residential generator system. Numbering of figures changed, respectively. Figure 2000.2 - Revised to reflect updated information. Figure 2000.3 - Revised to reflect updated information. Figure 2000.4 - Revised to reflect updated information. Figure 2000.5 - Revised to reflect updated information. Figure 2000.6 - Reflects new requirements outlined by the NEC.</p>
----------------------------	-------------------------------	--

TABLE OF CONTENTS

<u>SECTION/ARTICLE</u>	<u>TITLE</u>	<u>PAGE NO.</u>
SECTION 70	SAFETY	16
Article 70.1	General	16
Article 70.2	Safety around Buried Lines	16
Article 70.3	Safety around Overhead Lines	17
Article 70.4	Safety Tips for the Public	18
Article 70.5	Safety, Safety, Safety	19
SECTION 80	SUPPLY AND UTILIZATION FACILITIES	20
Article 80.1	Supply Facilities	20
Article 80.2	Utilization Facilities	20
Article 80.3	Defining Responsibilities at the Point of Delivery (POD)	20
Article 80.4	Referenced Codes and Standards	20
Article 80.5	Supplemental Provisions	20
Article 80.6	Informational Purposes Only	20
SECTION 90	GENERAL INFORMATION	21
Article 90.1	To Architects, Consulting Engineers and Electrical Contractors	21
Article 90.2	Customer Charges and Agreements	21
Article 90.3	Coordination of Service Installation Requirements	21
Article 90.4	Metering Equipment Design	22
Article 90.5	Access for CPS Energy Employees and Agents	23
Article 90.6	Easements	23
Article 90.7	Meter Tampering	23
Article 90.8	Attachment to CPS Energy Poles	23
Article 90.9	Discontinuous or Interruption of Service	23
Article 90.10	Requests for Deviation from Standards	24
SECTION 100	DEFINITIONS	25-38
SECTION 200	CHARACTERISTICS, TYPES AND AVAILABILITY OF ELECTRIC SERVICE	39
Article 201	Characteristics of Service	39
Article 202	Types of Electric Service, Overhead and Underground Distribution	39
Article 203	Sizing of CPS Energy Transformers	40
Article 204	Availability of Electric Service to Non-Residential Customers from an Underground Residential Distribution System	42
Article 205	Types of Electric Service and Demand Loads from Downtown Network System	42
Article 206	Number of Services	43
Article 207	Separate Services Supplied	44
Article 208	One Building or Other Structure Not to be Supplied Through Another	45
Article 209	Metering	45
SECTION 300	USE OF ELECTRIC SERVICE	47
Article 301	General	47

TABLE OF CONTENTS

Article 302	Continuity of Service.....	47
Article 303	Load Balancing and Voltage Drop.....	47
Article 304	Interference.....	47
Article 305	Induced Current in Metal Enclosures.....	48
Article 306	Interconnection of Power Sources on Customer Side of Point of Delivery.....	48
SECTION 400	SERVICE EQUIPMENT	50
Article 401	General.....	50
Article 402	Service-Entrance Conductors.....	50
Article 403	Service Disconnecting Equipment.....	50
Article 404	Means of Identifying Grounded and Ungrounded Conductors.....	51
Article 405	Location of Customer Service Disconnecting Equipment....	52
Article 406	Maximum Number of Disconnects.....	53
Article 407	Grouping of Disconnects.....	53
Article 408	Meter Disconnects for Self-Contained 480Y/277-volt Meters.....	54
Article 409	Meter Disconnects for Distributed Generation (DG).....	55
Article 410	Service Raceway Types Permitted	55
Article 411	Raceway Seal.....	55
Article 412	Downtown Network System.....	55
SECTION 500	OVERHEAD SERVICES (SERVICE DROPS UNDER 600 VOLTS)	56
Article 501	General.....	56
Article 502	Vertical Clearances.....	56
Article 503	Clearances on Buildings from Final Span of Service Drop Conductors.....	57
Article 504	Length.....	57
Article 505	Point of Attachment.....	57
Article 506	Service Raceway.....	58
Article 507	Service Masts.....	59
Article 508	Service Head.....	60
Article 509	Service-Entrance Conductors.....	60
Article 510	Metering.....	62
SECTION 600	OVERHEAD TO UNDERGROUND SECONDARY SERVICE	73
Article 601	General.....	73
Article 602	Standard Installation.....	73
Article 603	CPS Energy Riser Pole.....	74
Article 604	Service Lateral Conduits.....	74
Article 605	Service Lateral Conductors.....	77
Article 606	Service-Entrance Conductors.....	78
Article 607	Metering.....	79
SECTION 700	UNDERGROUND RESIDENTIAL DISTRIBUTION (URD) SERVICE	83
Article 701	General.....	83
Article 702	Standard Installation	84
Article 703	Transformers.....	84
Article 704	Service Lateral Conduits.....	85
Article 705	Service Lateral Conductors.....	87
Article 706	Service-Entrance Conductors.....	87
Article 707	Metering.....	88

TABLE OF CONTENTS

SECTION 800	UNDERGROUND SERVICE IN APARTMENT COMPLEXES	91
Article 801	General	91
Article 802	Standard Installation	91
Article 803	Transformers	92
Article 804	Service Lateral Conduit	93
Article 805	Service Lateral Conductors and Load	96
Article 806	Service-Entrance Conductors	97
Article 807	Approved Meter Locations	97
SECTION 900	SERVICE IN HIGH-RISE RESIDENTIAL BUILDINGS	101
Article 901	General	101
Article 902	Secondary Voltage Distribution System	101
Article 903	Primary Voltage Distribution System	102
Article 904	Electric Meter Rooms	108
SECTION 1000	COMMERCIAL OR INDUSTRIAL SERVICES FROM PADMOUNT DISTRIBUTION TRANSFORMERS	112
Article 1001	General	112
Article 1002	Standard Installation	112
SECTION 1100	SERVICE FROM DOWNTOWN NETWORK SYSTEM	128
Article 1101	General	128
Article 1102	Secondary Grid Service	128
Article 1103	Transformer Vault/Room Service	130
Article 1104	Services Located Outside of Building	138
Article 1105	Metering	138
SECTION 1200	COMMERCIAL SERVICES FROM SINGLE-PHASE UNDERGROUND RESIDENTIAL DISTRIBUTION PADMOUNT TRANSFORMERS	144
Article 1201	General	144
Article 1202	Sizing of CPS Energy Transformers	146
Article 1203	CPS Energy Job Sketch	146
Article 1204	Standard Installation	146
Article 1205	Secondary and Service Lateral	150
Article 1206	Metering	152
SECTION 1300	PRIMARY VOLTAGE SERVICE	156
Article 1301	General	156
Article 1302	Three-Phase Primary Voltage Service	156
Article 1303	Multiple Primary Voltage Services (Primary Circuits)	
Article 1304	Primary Voltage Service - Overhead	156
Article 1305	Primary Voltage Service - Underground	157
SECTION 1400	SERVICE TO CUSTOMER OWNED METER POLE	160
Article 1401	General	160
Article 1402	Installation of Meter Pole	160
Article 1403	Service Equipment	161
Article 1404	Metering Equipment	161
Article 1405	Other Equipment Not Permitted on Meter Pole	161
SECTION 1500	SERVICE IN MANUFACTURED HOME COMMUNITIES	165
Article 1501	General	165
Article 1502	Underground Residential Distribution System (URD)	165
Article 1503	Overhead Distribution System	166

TABLE OF CONTENTS

SECTION 1600	TEMPORARY SERVICE	169
Article 1601	General.....	169
Article 1602	Construction of Temporary Meter Structure.....	169
Article 1603	Temporary Service Laterals in URD Areas.....	169
Article 1604	Temporary Service Drops in Overhead Areas.....	170
SECTION 1700	GROUNDING OF SERVICES	174
Article 1701	General.....	174
Article 1702	Services Supplied by CPS Energy.....	174
Article 1703	Grounded Conductor (Neutral) Brought to Service Equipment.....	174
Article 1704	Grounding Electrode System.....	174
Article 1705	Customer's Equipment Grounding Conductor.....	175
Article 1706	Bonding of Service Equipment	175
Article 1707	Bonding for Other Systems (Intersystem Bonding)	176
Article 1708	Grounding of CPS Energy Service Drops and Laterals.....	176
SECTION 1800	METERING EQUIPMENT AND ITS INSTALLATION	178
Article 1801	General.....	178
Article 1802	Applications.....	178
Article 1803	CPS Energy Furnished Metering Equipment and General Installation Requirements.....	179
Article 1804	Customer Furnished Metering Equipment and General Installation Requirements.....	185
Article 1805	Location of Metering Equipment	192
Article 1806	Heights of Metering Equipment.....	193
Article 1807	Minimum Clearances and Working Space Required at Metering Equipment.....	194
Article 1808	Grouping of Meters.....	195
Article 1809	Use of Metering Equipment.....	202
Article 1810	Communication Provisions for Metering.....	204
SECTION 1900	CELL TOWER SITE AND WIRELESS COMMUNICATION SYSTEM	230
Article 1901	General.....	230
Article 1902	New Service Installations for Cell Tower Sites.....	230
Article 1903	Existing Service Installations.....	230
Article 1904	New Service Installation for Wireless Communication Systems.....	230
Article 1905	Technical Submittal Information.....	231
SECTION 2000	DISTRIBUTED GENERATION	240
Article 2001	General.....	240
Article 2002	Scope and Applicability.....	240
Article 2003	Downtown Network Systems Interconnection of DG.....	240
Article 2004	CPS Energy Facilities and System Modifications.....	240
Article 2005	Customer DG Facilities.....	241
Article 2006	Technical Information Required.....	244
Article 2007	Commissioning of DG System.....	244
Article 2008	Access to DG Sites.....	244
Article 2009	Operational Requirements for DG.....	245

SECTION 70

SAFETY



70.1 General:

CPS Energy's most important resource is its employees. Therefore, it is our responsibility to ensure the safety and well-being of each and every employee as well as the public at large. CPS Energy is committed to the development and implementation of Safety and Health Policies, Plans, Programs, and Procedures, which provides a safe environment where our employees can work without accident or injury, and in doing so, protects our community members. It is a priority and core value to inspire and ensure a culture of safety throughout our organization.

70.1.1 Leadership's Commitment:

CPS Energy Executives, Managers, and our Union are all committed to helping create a safe working environment free from hazards. Leaders promote safety through their engaged leadership inspiring safe actions at all levels of our organization.

70.1.2 Employees' Commitment:

To ensure safety when working around electric utility equipment, CPS Energy personnel must understand electrical safety standards and regulations, adhere to established electrical safety policies and programs, understand electrical hazards, safe work procedures, proper donning of Personal Protective Equipment (PPE), and be committed to improving electrical system safety through design. All employees are accountable for their safety, the safety of others who work with them, and the public's safety.

70.1.3 Impact on Customer Safety:

By establishing safety as one of our core values, our Customers as end users can be assured that they are being delivered a quality, reliable, and safe service from CPS Energy.

70.1.4 Working on CPS Energy Electric Lines Not Permitted:

For safety reasons, only authorized CPS Energy personnel may install, operate, maintain, or access electric lines. Any unauthorized access or work on electric lines may result in injury or death.

70.2 Safety around Buried Power Lines:

As a Customer, it is impossible to know where underground power lines may be located or to judge how deep they may be buried. Coming into contact with these lines with a shovel or other equipment can cause serious injury or death.

In accordance with the Damage Prevention Bill for Texas (House Bill 2295), Customers and/or Contractors are required to contact the "One-Call" Center telephone number and follow the four-step process of the "Dig Safely" program prior to beginning any excavation in order to have buried utility lines located and marked for their safety (Refer to "Helpful Numbers" listed on the inside front cover page).

70.2.1 "One-Call" (Electric and Gas Line Locator Service):

The Damage Prevention Bill for Texas (House Bill 2295) took effect October 1998, and is known as the Texas Utilities Code, Title 5, Chapter 251 "Underground Facility Damage Prevention and Safety". This law requires facility owners to join a notification "One-Call" Center and requires excavators to call 48 hours prior to digging. It also requires any notification ("One-Call") center operating in Texas to share messages they

receive between the notification centers. This provision is to ensure that excavators need only make one call to notify most facility owners with buried utilities.

70.2.2 The "Dig Safely" Program:

This program was introduced nationwide in June 1999. Its purpose is to help protect underground utility lines from damage by excavators and protect excavators from the hazards of damaging energized underground lines. The "Dig Safely" program stresses that safe excavation is a four-step process:

(1) Call Before You Dig:

The "One-Call" Center is an integral part of the damage prevention process. Customers may contact the One Call Center by dialing 811 from anywhere in the country a few days prior to digging, and their call will be routed to a local One Call Center. Tell the operator where you are planning to dig and what type of work you will be doing; CPS Energy as your local utility company will be notified about your intent to dig. CPS Energy will coordinate to locate and mark the approximate location of your underground lines, pipes, and cables, so you will know what is below and be able to dig safely (Refer to "Helpful Numbers" listed on the inside front cover page).

(2) Wait the Required Amount of Time:

Texas law requires at least two working days' notice before beginning excavation. This means a homeowner who is putting in a fence on Saturday must call no later than Wednesday.

(3) Respect the Marks:

CPS Energy or its agents will mark the approximate location of buried electric and gas facilities using paint, flags, stakes, or a combination. During the project, it is the excavator's responsibility to make sure the utility marks remain visible. If the utility locate markings are removed, missing or not clearly visible, the excavator must call for a re-mark.

(4) Dig Safely:

Once the work begins it is up to the excavator to use safe and accepted digging practices. Regardless of how careful the preparation has been the excavation work must be performed in a prudent and careful manner. The "Dig Safely" campaign is the result of cooperation between the National Transportation Safety Board, Office of Pipeline Safety, and representatives from the industries that own and operate underground facilities. These industries include communications (local, long distance, and CATV), electric power and gas utilities, pipelines, municipalities, and local, state, and federal regulatory agencies.

70.3 Safety around Overhead Power Lines:

Overhead power lines are for the most part not insulated; therefore, extreme care must be taken to ensure that safe distances are maintained by all personnel and equipment. TEXAS LAW, Texas Health and Safety Code, Chapter 752 forbids all activities in which, persons or things may come within 10 feet of live overhead high voltage lines. The law also forbids the operation of equipment such as: cranes, derricks, drilling rigs, hay loaders or similar equipment, any part of which is capable of vertical, lateral, or swinging motion within 10 feet of live overhead high voltage lines.

Note: *To arrange for electric lines to be de-energized, temporarily relocated, temporarily marked or for other arrangements, contractors shall contact the CPS Energy Customer Service Representative (Refer to "Helpful Numbers" listed on the inside front cover page).*

70.3.1 Minimum Clearance from Overhead Lines:

CPS Energy maintains minimum clearances from overhead electric transmission and distribution lines to any building or other structure in accordance with the provisions of the National Electric Safety Code (NESC) and regulations established by CPS Energy's Transmission and Distribution Engineering Departments.

(A) Customer Buildings or Structures:

Customers constructing buildings and/or any other structures shall not cause minimum clearances to be compromised. Customers shall coordinate with CPS Energy where constructing buildings or structures near overhead transmission or distribution lines.

(B) Relocation of Overhead Electric Lines:

If relocation or modification of CPS Energy transmission or distribution facilities is necessary to prevent violation of minimum clearances, Customer shall be responsible for expenses associated with any actions taken by CPS Energy.

(C) Safety of Workers:

Contractors and owners are legally responsible for the safety of construction workers. This law carries both criminal and civil liability.

(D) Tree Trimming Near Power Lines:

Where performing tree trimming near energized power lines, Customers shall contact CPS Energy prior to trimming or cutting trees to avoid possible injury and/or damage to electric distribution lines and equipment.

70.3.2 Downed Power Lines:

Customers should contact CPS Energy immediately where witnessing a downed power line. Assume that all downed power lines are energized and stay away. Call 911 immediately if it is a medical or life-threatening emergency.

Never touch someone who may be in contact with a power line; touching them can cause you to become a victim yourself. Instead contact CPS Energy or the fire or police department immediately (Refer to "Helpful Numbers" listed on the inside front cover page).

70.4 Safety Tips for the Public:

Electricity in the home or business can be dangerous and Customers should take every precaution to use it safely. As parents and community leaders we need to continue to talk to children about the dangers of electricity. The following are some basic safety rules that everyone should follow:

- (1) Never climb or play in trees that are located near overhead power lines.
- (2) Only fly kites in an open field and never near overhead power lines. Should your kite get tangled with a power line, call CPS Energy immediately. Never try to get it untangled as this can cause serious injury.

SECTION 70 - SAFETY

- (3) Remote-controlled model airplanes and drones can cause serious damage and power outages if they come in contact with overhead power lines. Never operate these around overhead power lines.
- (4) Do not touch someone that may be in contact with an energized electric line. Instead you should call the police or fire department immediately for help.
- (5) Stay clear of power substation fences and electrical equipment. Never attempt to climb power substation fences or other CPS Energy equipment.
- (6) Be careful with electrical outlets and never attempt to insert anything other than approved electrical plugs.
- (7) Electricity and water do not mix. Never touch any electrical equipment or cords when you are wet or in contact with water.
- (8) Never pour water onto an electrical fire. This can cause serious injury and does not work to extinguish the fire.

70.5 Safety, Safety, Safety:

There are literally hundreds of ways to practice safety in our everyday lives. Whether you work in the field or in an office or even if you are home relaxing, safety should always be a priority. Customers may contact CPS Energy for more electric and gas safety information (Refer to the "Helpful Numbers" listed on the inside front cover page).



SECTION 80

**SUPPLY AND UTILIZATION
FACILITIES**



80.1 Supply Facilities:

CPS Energy designs, installs, and operates its electric supply facilities in accordance with sound engineering practices and policies by CPS Energy and in accordance with the National Electrical Safety Code (NESC) and the Occupational Safety and Health Administration (OSHA).

80.2 Utilization Facilities:

On the load-side of the point of delivery, electric utilization facilities and equipment, including service equipment, are generally designed and installed in accordance with the requirements of the National Electrical Code (NEC) and applicable codes adopted by municipalities and the state of Texas.

80.3 Defining Responsibilities at the Point of Delivery (POD):

Supply facilities up to the point of delivery are governed by the NESC and CPS Energy. Utilization facilities are governed by the NEC and respective municipalities. CPS Energy has established requirements in these Service Standards that extend beyond the POD for those cases where CPS Energy metering equipment and/or the main service equipment is installed beyond this point.

80.4 Referenced Codes and Standards:

The codes and standards referenced in this code shall mean the current edition of the NEC as adopted by the City of San Antonio, State of Texas or other municipal inspection authority at time of construction and the current edition of the NESC. These codes and standards shall be considered part of the requirements of this code to the prescribed extent of each such reference. Where conflicts occur between provisions of this code, referenced codes, and standards, the provisions of this code shall apply.

80.5 Supplemental Provisions:

The provisions provided herein are intended to supplement the requirements of the NEC and NESC, along with any other applicable codes, at the POD. Many of the definitions and terminologies herein are matched to referenced codes and standards including the NEC. However, in some cases the definitions and terminologies have been modified or amended to incorporate specific requirements deemed necessary by CPS Energy.

Note: Reprinted with permission from NFPA 70-2017, National Electrical Code®, Copyright © 2016, National Fire Protection Association, Quincy, MA 02169. The reprinted material is not complete and official position of the NFPA on the referenced subject, which is represented only the standard in its entirety.

80.6 Informational Purposes Only:

This publication is for information purposes only and in no way shall this publication be construed to impose any liability upon CPS Energy. CPS Energy makes no warranties or representations herein expressed or implied, including but not limited to merchantability and fitness for a particular purpose.



SECTION 90

**GENERAL
INFORMATION**



90.1 To Architects, Consulting Engineers and Electrical Contractors:

These standards are issued by CPS Energy to provide minimum technical standards for materials and construction practices utilized in the installation of electric service. CPS Energy documents entitled: "Policy for Electric Line Extensions and Service Installations" and "Rules and Regulations Applying to Retail Electric and Gas Service" will outline conditions for service.

90.1.1 Revisions:

The standards herein supersede all previous publications of "CPS Energy's Electric Service Standards".

90.1.2 Supplemental Rules and Regulations:

The standards herein are supplementary to the rules and regulations of the City of San Antonio, other municipalities' adopted codes, county ordinances, the NESC, and the NEC.

90.2 Customer Charges and Agreements:

Customer charges, including estimates associated with electric line extensions, new service installations, and modifications to existing services are in accordance with CPS Energy documents entitled: "Policy for Electric Line Extensions and Service Installations" and "Rules and Regulations Applying to Retail Electric and Gas Service". Copies of these documents are available from CPS Energy's Customer Service Representative.

90.3 Coordination of Service Installation Requirements:

Service installations and modifications must be coordinated with CPS Energy's Customer Service Representative. Customer will be required to furnish electrical drawings deemed necessary by CPS Energy's Customer Service Representative. The Customer is encouraged to stay in contact with CPS Energy's Customer Service Representative during the design stages of a project to ensure that all electric service installation requirements are met.

90.3.1 Coordination with Customer Service Representative:

The CPS Energy Customer Service Representative will coordinate all service installation requirements between the Customer and internal CPS Energy Engineering and Construction Departments. This coordination will include: arranging meetings when required, communicating technical standards and specifications, and furnishing final construction sketches, if applicable.

90.3.2 Plans and Specifications Prepared by Engineer:

New electric service installations or modifications to existing electric services involving Customer calculated loads rated over 600 amperes at 250 volts to ground or less, or rated at over 400 amperes and greater than 250 volts to ground, or any system above 600 volts nominal shall have the electrical plans sealed by a professional engineer, licensed or registered with the State of Texas.

The following list identifies the service voltages offered by CPS Energy and the corresponding ampere values that will require a licensed or registered professional engineer:

SECTION 90 - GENERAL INFORMATION

- 480Y/277-volt, Four-Wire, Three-Phase, 400 Amperes (333 kVA)
- 208Y/120-volt, Four-Wire, Three-Phase, 600 Amperes (216 kVA)
- 240/120-volt Delta, Four-Wire, Three-phase, 600 Amperes (250 kVA)
- 120/240-volt, Three-Wire, Single-phase, 600 Amperes (144 kVA)

Exception 1: Where designs involve the installation or modification of CPS Energy supply facilities on the line-side of the point of delivery, CPS Energy may require documents to be prepared by a licensed or registered engineer at lesser kVA values when deemed necessary due to special conditions or other considerations (Refer to Definition of "Supply Facilities").

Exception 2: Where Distributed Generation (DG) systems are designed to be interconnected on the line-side or load-side of the Customer's service disconnecting means, CPS Energy will require documents to be prepared by a licensed or registered engineer for all designs of 25 kWAC and above for any voltage (Refer to Section 2000).

Exception 3: Where otherwise required by the Texas Engineering Practice Act the electrical plans shall be sealed by a licensed or registered engineer.

90.4 Metering Equipment Design:

CPS Energy no longer provides single-phase, self-contained meter sockets to electrical contractors. Single-phase, self-contained meter sockets approved by CPS Energy are listed on Figure 1800.1 and may be purchased through local distributors. All other metering equipment listed in Table 1800.1 will be furnished by CPS Energy. Customer may order CPS Energy furnished metering equipment at completion of application for service. The Customer is advised to plan their job in accordance with these Standards and to specify code numbers from Table 1800.1 when ordering metering equipment.

Customer must coordinate with CPS Energy's Customer Service Representative to order necessary metering equipment before wiring is started. Where Customer design requires the use of metering instrument transformer enclosures larger or different than those listed in Table 1800.1, Customer must submit manufacturer's shop drawings and specifications for review by CPS Energy. Such enclosures must be approved by CPS Energy prior to installation and be furnished and installed by Customer at Customer's expense (Refer to Section 1800).

90.4.1 Meter Locations:

Customer shall consult with CPS Energy's Customer Service Representative regarding the location of metering equipment. CPS Energy's Customer Service Representative will make final determination on the location of metering equipment (Refer to Section 1800).

90.4.2 Instrument Transformer Rated Metering Equipment:

Estimated three-phase demand or calculated loads over 288 amperes on 208Y/120-volt, 240/120-volt closed-delta, or 480Y/277-volt services will require the use of instrument transformer rated metering equipment.

Estimated single-phase demand or calculated loads over 288 amperes on 120/240-volt service will require the use of instrument transformer rated metering equipment.

Note 1: Services with single or parallel conductors that exceed the self-contained meter sockets' cable specifications and all services with voltages greater than 480 volts will require the use of instrument transformer rated metering equipment (Refer to Section 1800).

Note 2: *The Customer, when coordinating any service installation or modification, should always consider the possibility that instrument transformer rated metering equipment may be needed in the design of the meter loop.*

90.5 Access for CPS Energy Employees and Agents:

The Customer shall give employees of CPS Energy and its authorized agents, when properly identified, access to the premises of the Customer at all reasonable hours and any time during an emergency. This access will be for installing, reading, inspecting, adjusting, repairing, maintaining, replacing, or removing any CPS Energy equipment on Customer's premises, or for any other purpose incidental to the electric service supplied by CPS Energy.

90.6 Easements:

Customer shall furnish CPS Energy, without charge, appropriate easements as specified by CPS Energy's Customer Service Representative. Customer shall be responsible for providing unrestricted access and making all CPS Energy equipment readily accessible to CPS Energy.

90.6.1 Types of Easements:

CPS Energy's Customer Service Representative will coordinate with Customer and specify appropriate types and locations of easements necessary for the provision of electrical service to Customer's premises.

90.6.2 Use Restrictions:

Buildings, signs, swimming pools, decks, equipment, or any other permanent structures within electrical easements are prohibited. CPS Energy easements must comply with the provisions established by CPS Energy.

90.7 Meter Tampering:

The Customer shall not bypass, tamper with, or otherwise interfere with the proper operation and registration of CPS Energy metering equipment.

Note 1: *Equipment and wiring shall not be connected to facilities in such a manner as to bypass metering equipment required by CPS Energy.*

Note 2: *Violations of the provisions outlined in this Section will cause service to be disconnected and those responsible to incur criminal and civil penalties as provided for by the City of San Antonio and State of Texas Statutes.*

90.8 Attachment to CPS Energy Utility/Streetlight Poles:

Attaching any Utility facilities or Banner equipment to utility/streetlight poles shall be prohibited without first obtaining approval from CPS Energy's Pole Attachment Services (Refer to "Helpful Numbers" listed on the inside front cover page).

90.9 Discontinuous or Interruption of Service:

CPS Energy reserves the right to discontinue, interrupt or curtail service to any Customer or refuse service to any Customer, when in the judgment of CPS

SECTION 90 - GENERAL INFORMATION

Energy, supply of service would constitute a safety or health hazard, for any condition outlined in CPS Energy's document entitled: "Rules and Regulations Applying to Retail Electric and Gas Service" or in accordance with any other policies adopted by CPS Energy.

90.10 Requests for Variance from Standards:

Requests for variance from CPS Energy's Electric Service Standards and specifications (service voltage, minimum and maximum loads, etc.) which are defined, described, detailed, or otherwise noted herein, will be evaluated on a case by case basis. Consultation with CPS Energy's Customer Service Representative will be required prior to a variance request being reviewed and considered by CPS Energy. If a variance is not approved, the Customer will be required to redesign their installation to comply with these Standards.

SECTION 100

DEFINITIONS



SECTION - 100 DEFINITIONS

Accessible: (As applied to equipment)

Admitting close approach: Not guarded by locked doors, elevation, or other effective means.

Accessible: (As applied to wiring methods)

Capable of being removed or exposed without damaging the building structure or finish, or not permanently closed in by the structure or finish of the building.

Accessible, Readily:

Capable of being reached quickly for operation, renewal, or inspections, without requiring those to whom ready access is requisite to climb over or remove obstacles or to resort to portable ladders, chairs, and so forth.

Ampacity:

The maximum current, in amperes, a conductor can carry continuously under the conditions of use without exceeding its temperature rating.

ANSI:

American National Standards Institute.

Authority Having Jurisdiction (AHJ):

An organization, office or individual responsible for enforcing the requirements of a code or standard, or for approving equipment, materials, and installation or a procedure on the load-side of the point of delivery.

Bonding:

The electrical interconnecting of conductive parts designed to maintain a common electrical potential.

Bonding Jumper:

A reliable conductor to ensure the required electrical conductivity between metal parts required to be electrically connected.

Bonding Jumper Main:

The connection between the grounded circuit conductor and the equipment grounding conductor at the service.

Building:

Building referred to in these standards includes all occupancies within the same outside walls under a common roof. Individual occupancies or buildings separated by firewalls or fire barriers do not constitute separate buildings for the purpose of receiving electric service drops or laterals.

Calculated Load:

The term "calculated load" as used herein shall mean the maximum load in kVA on the load-side of the point of delivery as calculated in accordance with the National Electrical Code (NEC) and other applicable codes. Calculated load may be expressed in terms of amperes, or volt-amperes.

City Electrical Code (CEC):

The latest edition of the Electrical Code of the City of San Antonio (COSA), Texas; that code incorporates and makes a part thereof the CPS Energy's Electric Service Standards.

SECTION - 100 DEFINITIONS

CPS Energy:

The gas and electric utility supplying principally the City of San Antonio, Texas, and County of Bexar.

Concealed:

Rendered inaccessible by the structure or finish of the building. Wires in concealed raceways are considered concealed, even though they may become accessible by withdrawing them.

Conductor:

A material, usually in the form of a wire, cable, or busbar, suitable for carrying an electric current.

Conductors Considered Outside of Building:

Conductors shall be considered outside of a building or other structure under any of the following conditions:

- (1) Where installed in conduit that is encased in not less than 2 inches of concrete beneath a building or other structure.
- (2) Where installed within a building or other structure in a raceway that is encased in concrete or brick not less than 2 inches thick.
- (3) Where installed in any vault that meets the construction requirements of the NEC and CPS Energy specifications.
- (4) Where installed in conduit and under not less than 24 inches of earth beneath a building or other structure.

Conduit:

A single channel designed and approved specifically for electrical conductors (Refer to definition of Raceway).

Continuous Load:

A continuous load is a load where the maximum current is expected to continue for three hours or more (as defined by the NEC for design calculations).

Customer:

Any individual, partnership, association, joint venture, firm, public or private corporation or governmental agency who is an applicant for, or who is receiving the benefit of electric service at a specified point of delivery from CPS Energy. The term will also include any authorized representative who designs or constructs the service and meter installation.

Customer's Installation:

In general, all wiring, devices, apparatus and appliances of any kind or nature on Customer's side of the point of delivery (POD), except CPS Energy meter installation, useful in connection with Customer's ability to take electric service. Customer's installation shall be terminated at a suitable location as determined by CPS Energy.

Customer's Responsibility:

Customer assumes all responsibility on Customer's side of the point of delivery, excluding CPS Energy's meter, for the service supplied or taken, as well as

SECTION - 100 DEFINITIONS

for the Customer's installation including appliances and apparatus used in conjunction therewith.

Demand Load:

The term "demand load" as used herein shall mean the maximum load in kilowatt per phase on the line-side of the point of delivery during any time interval use. The maximum demand will be determined by appropriate CPS Energy personnel and will be used to determine the size and rating of all equipment used in the CPS Energy service installation. Demand load may be expressed in terms of amperes or volt-amperes.

Distributed Generation (DG):

An electrical generating facility located within the CPS Energy service territory of less than 10 MW and connected at a voltage of 35 kV and below which may be connected in parallel operation to the CPS Energy system. The facility may include energy storage technologies as well as conventional generation technologies.

Downtown Network System:

This system is totally underground and consists of multiple parallel circuits on the primary and secondary sides of the system. There are two types of services provided to Customers in the Downtown Network System: Secondary Grid Service and Transformer Vault/Room Service.

Duct:

An underground channel including one or more conduits encased in concrete used for conductors and constructed in accordance with CPS Energy specifications. Duct as used herein, will be applicable to commercial installations only and be referenced within this book as; ductline, ductbank, and underground duct.

Electric Service:

Electric power distributed or made available by CPS Energy at the point of delivery. The availability of electric service to all Customers for all general use irrespective of whether any electric energy is actually taken.

Enclosure:

The case or housing of apparatus, or the fence or wall that surrounds an installation to prevent personnel from accidentally contacting energized parts, and to protect the equipment from physical damage.

Energy, Electrical:

Electrical power (kilowatts) consumed over a given amount of time. The unit of energy as used herein shall be the kilowatt-hour. (Kilowatt-hour is 1000 watt-hours).

Fire Barrier:

A fire resistance rated vertical or horizontal assembly of materials designed to restrict the spread of fire in which openings are protected. Fire barriers shall subdivide floors and be attached to or supported by structural members. Fire barriers shall be rated for 2-hour minimum fire resistance and extend from the floor-to-floor or floor-to-roof. Construction of fire barrier shall be in accordance with the building codes adopted by the City of San Antonio (COSA).

Fire Wall:

A fire resistance rated wall having protected openings, which restricts the spread of fire and extends continuously from the foundation to or through the roof, with sufficient structural stability under fire conditions to allow collapse of construction on either side without collapse of the wall. Construction of fire wall shall be in accordance with the building codes adopted by the City of San Antonio (COSA).

Fuse Pad:

A service rated fuse pad furnished and installed by CPS Energy within a transformer vault or room that will be used by CPS Energy to disconnect the Customer's secondary service conductors from the distribution network. The fuse pad shall be property of CPS Energy.

Garden Style Apartment Complex:

Typically consists of apartment buildings built with landscaped grounds surrounding them. Other than a couple of buildings that may be used for leasing and/or renting purposes and for housing pool related equipment, the apartment buildings are for residential use and often arranged around courtyards that are open at one end. Each apartment typically has its own building entrance, or just a few apartments share a small foyer or stairwell at each building entrance. Modern garden apartment buildings are usually not more than three stories high since they typically do not have elevator or lifts.

Grid-Tied Disconnect:

A service rated disconnect furnished and installed by Customer on their premises that will be used by CPS Energy to disconnect the Customer's secondary service conductors from the Downtown Network System. The grid-tied disconnect shall be under the exclusive control of CPS Energy and remain locked and sealed by CPS Energy personnel at all times.

Grid-Tied Fuse Pad:

A service rated fuse pad furnished and installed by CPS Energy on Customer's premises that will be used by CPS Energy to disconnect the Customer's secondary service conductors from the Downtown Network System. The grid-tied fuse pad shall be property of CPS Energy and remain locked and sealed by CPS Energy personnel at all times.

Ground:

A ground is a connection, either intentional or accidental, between an electrical circuit and the earth or some conducting body serving in place of the earth.

Ground-Fault:

An unintentional electrically conducting connection between an ungrounded (phase) conductor of an electrical circuit and the normally non-current carrying conductors, metallic enclosures, metallic raceways, metallic equipment, or earth.

Ground-Fault Current Path:

An electrically conductive path from the point of a ground-fault on a wiring system through normally non-current carrying conductors, equipment, or the earth to the electrical supply source.

Ground-Fault Protection:

This function trips (opens) a circuit breaker or sounds an alarm in the event that there is an electrical fault between one or more of the ungrounded (phase) conductors and ground (earth). This ground-fault protection function may be incorporated into a circuit breaker.

Grounded:

Connected to or in contact with earth or connected to some extended conductive body that serves instead of the earth.

Grounded Conductor:

A system or circuit conductor that is intentionally grounded.

Grounded Effectively:

Intentionally connected to earth through a ground connection or connections of sufficiently low impedance and having sufficient current carrying capacity to limit the buildup of voltages to levels below that which may result in undue hazard to persons or to connected equipment.

Grounding Conductor:

A conductor used to connect equipment or the grounded circuit of a wiring system to grounding electrode or electrodes.

Grounding Electrode:

A conducting object through which a direct connection to earth is established.

Grounding Electrode Conductor:

A conductor used to connect the system grounded conductor or the equipment to a grounding electrode or to a point on the grounding electrode system.

Harmonics:

Harmonics are voltage or current components which operate at integral multiples of the fundamental frequency of a power system (50 or 60 Hertz). Harmonic currents have the effect of distorting the shape of the voltage wave form from that of a pure sine wave.

Harmonic Distortion (Total Harmonic Distortion):

Total harmonic distortion is an expression of the total harmonic content of a voltage waveform. The harmonic distortion (or harmonic content) of a waveform is usually expressed as the square root of the sum of the squares of each of the harmonic amplitudes (with amplitudes as a percent of the fundamental voltage amplitude).

High-Rise Building:

A residential use building consisting of six or more floors.

Instrument Transformer:

A transformer that reproduces in its secondary circuit in a definite and known proportion, the voltage or current of its primary circuit with the phase relation substantially preserved.

Current Transformer (CT):

A CT is an instrument transformer used for measurement purposes and is designed to have its primary (highest current) winding connected in series

SECTION - 100 DEFINITIONS

with a circuit, the current of which is to be measured. Most CT's are window type (donut-type), with the service conductor passing through the CT opening and serving as the primary winding.

Voltage Transformer (VT):

A VT is an instrument transformer intended for measurement or control purposes which is designed to have its primary winding connected in parallel with a circuit, the voltage of which is to be measured or controlled.

Interconnection Facilities:

All facilities required by CPS Energy as a result of the Distributed Generation (DG) interconnection, to allow the safe and reliable interconnection and parallel operation of the DG system.

Kilovolt Amperes (kVA):

A term used for rating electrical devices. A device's kVA rating is equal to its rated output in amperes multiplied by its rated operating voltage. Kilovolt amperes is the vector sum of the active power (kW) and the reactive power (kVAR) flowing in a circuit.

Kilovolt-Amperes-Reactive (kVAR):

The product of the voltage and the amperage required to excite inductive circuits. It is associated with the reactive power which flows between paralleled generator windings and between generators and load windings that supply the magnetizing currents necessary in the operation of transformers, motors, and other electromagnetic loads. Reactive power does not load the generator set's engine but does limit the generator thermally.

Kilowatt (kW):

This is an abbreviation for kilowatt, an alternate term for rating electrical devices. Generator sets in the United States are usually rated in kW. Sometimes called active power, kW loads the generator set engine.

Kilowatt-Hour (kWh):

This is a unit of electric energy. It is equivalent to one kW of electric power supplied for one hour.

Listed:

Equipment, materials or services included in a list published by a Nationally Recognized Testing Laboratory (NRTL) recognized and approved by the Occupational Safety and Health Administration (OSHA) and concerned with evaluation of products or services, that maintains periodic inspection of production of listed equipment or materials or periodic evaluation of services, and whose listing states that either the equipment, material or service meets appropriate designated standards or has been tested and found suitable for a specified purpose.

Meter, Revenue: (kWh or kWh/kW)

The device or any auxiliary equipment installed by CPS Energy to measure electric energy taken by the Customer.

Note: Meters are classified as either single-phase or three-phase and are either self-contained or transformer rated. Self-contained meters operate directly from the service voltage and load current. Transformer rated meters

SECTION - 100 DEFINITIONS

require current transformers (CT's) or voltage transformers (VT's), or both, to reduce the service current or voltage when they are beyond the measuring capacity of self-contained meters.

Meter Disconnect Switch:

A meter disconnect switch shall be rated not more than 600 volts and have a short-circuit current rating equal to or greater than the available short-circuit current. Meter disconnect switch shall be capable of interrupting the load served. The disconnect housing shall be metal and be grounded and bonded in accordance with applicable codes.

Meter Disconnect Switch, 480 Volt:

A meter disconnect switch that shall be installed ahead of self-contained 480 volt kWh meter sockets.

Meter Disconnect Switch, Distributed Generation (DG):

A meter disconnect switch that shall be installed ahead of a CPS Energy kWh meter in order to isolate from DG power source.

Metering Equipment:

The metering equipment shall consist of self-contained and transformer rated meter sockets, current transformers (CT's), voltage transformers (VT's), primary metering cabinets, transockets, meter pedestals, modular metering equipment, meter disconnects, all necessary enclosures, and associated support equipment as required by CPS Energy.

Metering Equipment Rack (Meter Rack):

A free-standing structure used to support metering and service equipment. Typically, a meter rack consists of a minimum of two, 2-inch rigid capped pipes set in 2 feet of concrete with a minimum of two Kindorf horizontal members. However, size and number of rigid capped pipes and number of horizontal supports will depend on equipment to be supported and length of structure (Refer to Figure 1800.20).

Meter Loop:

The meter loop is all wiring, connections, associated raceways, instrument transformer enclosure or meter socket required to connect metering equipment to a Customer's residence or place of business. This equipment usually consists of service lateral or service-entrance conductors within the meter or instrument transformer enclosure or meter socket for connection to the line- and load-side of metering equipment.

Meter Pole:

A chemically treated wood pole, steel pole, or equivalent, owned and maintained by Customer and used for terminating the service drop and supporting the meter and service equipment (Refer to Section 1400).

Meter Pedestal:

A CPS Energy pre-approved single stand-alone weatherproof electrical enclosure consisting of a utility pull section with optional single meter socket, and a Customer section containing optional distribution and control equipment. All electrical equipment (lug landing, meter socket, distribution, and control equipment) are protected within type 3R cabinet. Utility metering and lug landing compartments are isolated from Customer distribution and optional

SECTION - 100 DEFINITIONS

control section. The unit may be padmount or concrete embedded on or in a minimum 18-inch diameter by 20-inch depth concrete base (Refer to Figure 1500.1).

Meter Room (Electrical):

A dedicated room approved by CPS Energy that is provided and maintained by Customer solely for housing electric meters and service equipment. The room and equipment therein shall be readily accessible to authorized CPS Energy persons. Customer shall provide permanent lighting in the meter room.

Meter Socket:

Meter sockets are classified as either single-phase or three-phase and are either self-contained or transformer rated. Self-contained meter sockets operate directly from the service voltage and load current. Transformer rated meter sockets require current transformers (CT's) or voltage transformers (VT's), or both, to reduce the service current or voltage when they are beyond the ampacity of self-contained meter sockets.

National Electrical Code (NEC) (ANSI/NFPA 70):

An American National Standard published by the National Fire Protection Association for the purposes of safeguarding persons and property from hazards arising from the use of electricity and setting forth provisions considered necessary for safety. Electrical contractors must abide by the NEC, for internal and external wiring of buildings and structures.

This Code shall be referred to herein as the NEC and shall mean the edition of the code approved by the City of San Antonio. In all other areas, the NEC shall mean the edition of the code approved by the State of Texas or the appropriate authority having jurisdiction.

National Electrical Code and NEC are registered trademarks of the National Fire Protection Association, Quincy, MA.

National Electrical Safety Code (NEC) (ANSI C2):

An American National Standard published by the Institute of Electrical and Electronics Engineers, Inc. (IEEE). The purpose of the NEC is the practical safeguarding of persons during the installation, operation, or maintenance of electric supply and communication lines and associated equipment. It shall be the 2017 edition and all subsequent editions.

Nipple:

Shall be rigid metallic conduit (RMC) or intermediate metal conduit (IMC) not exceeding 24 inches in length. Equipment grounding and/or bonding as per applicable requirements.

Note:

The use of the term "Note" in these standards shall be intended to convey general information as well as mandatory requirements specifically referenced within.

Overhead Distribution Area:

All areas within the CPS Energy boundary lines except that area served from the CPS Energy Downtown Network System.

Overcurrent:

Any current in excess of the rated current of equipment or the ampacity of a conductor. It may result from overload, short-circuit, or ground-fault.

Overload:

Operation of equipment in excess of normal full-load rating, or of a conductor in excess of rated ampacity that, when it persists for a sufficient length of time, would cause damage or dangerous overheating. A fault, such as a short-circuit or ground-fault, is not an overload.

Parallel Operation:

Parallel Operation is the operation of two or more sources of AC electrical power whose output leads are connected to a common load. Connection of the power sources is made so that the sources electrically function as a single source of power. Parallel Operation requires that the two sources of electrical power must match in voltage, frequency, and number of phases.

Point of Common Coupling:

From the perspective of the Distributed Generation (DG), this is the nearest point on the CPS Energy system where other Customers can be connected. This is generally the point where system voltages and harmonics are metered, as it best represents the DG's impact on other Customers on the CPS Energy system.

Point of Delivery: (POD)

The point where the electric energy first leaves the conductors or devices owned by CPS Energy, and enters the service-entrance, other conductors or devices owned by Customer, unless otherwise specified in Customer's Service Agreement.

Customer assumes all responsibility on Customer's side of the point of delivery for service supplied or taken, as well as for Customer's installation including appliances and apparatus used in conjunction therewith.

The precise point of delivery is well defined herein and is intended to be applicable to the majority of services. All parties concerned must recognize that isolated circumstances not covered in this document may require delivery at a point other than specified herein.

Common Points of Delivery:

(A) Service Drops:

Where there is a point of junction between CPS Energy service drop conductors and Customer's service-entrance conductors, the point of delivery will be at that junction (service head). Where CPS Energy has existing service conductors continuous and unbroken to a meter socket or enclosure, the point of delivery will be at the load-side of the meter socket or load-side of the metering current transformers.

(B) URD Areas and Apartment Complexes with Underground Service:

On one meter installations, the point of delivery will be at the load-side of the meter socket or load-side of the metering current transformers. Where a main disconnecting device is installed ahead of meters, the point of delivery will be on the line-side of the main disconnect device. Customer shall provide cable terminating lugs appropriate for cable size. When CPS

SECTION - 100 DEFINITIONS

Energy owned service laterals supply two or more meters, the point of delivery will be in a junction box ahead of an auxiliary wire gutter as required and specified by CPS Energy (Refer to Fig. 1800.15).

Exception No. 1: *Where one to six meters are served from a Customer owned Meter Module, the point of delivery will be at the line-side of Meter Module main lug only bus, or line-side of main breaker. Customer shall provide cable terminating lugs appropriate for cable size. Meter Modules are owned and maintained by the Customer.*

Exception No. 2: *Where an auxiliary wire gutter is sized to a minimum of 16" H x 8" D and is used to supply not more than two residential dwelling units or apartments, an external junction box is not required and the point of delivery will be in the auxiliary wire gutter.*

Exception No. 3: *Where step-bus gutters meeting CPS Energy specifications are used by Customer and length is adequate to supply the maximum number of meters that may be supplied from gutter, an external junction box is not required and the point of delivery will be at bus gutter.*

(C) Padmount Transformers:

Where padmount transformers are installed to serve commercial or industrial Customers or high-rise residential use buildings, the point of delivery will be at the secondary transformer spades, regardless of meter location.

Exception: *Where a tap box is required in accordance with Section 1000, the point of delivery will be in the tap box.*

(D) Underground Service from Overhead Distribution:

Where an underground service is taken from a transformer or secondary on a CPS Energy pole in the Overhead Distribution area, the point of delivery will normally be at the meter equipment located outdoors on Customer's building or structure. Where meters are grouped with wire gutters in accordance with Section 1800 and a bussed gutter is used, the point of delivery will be in the bus gutter, or it will be in the main disconnect ahead of the gutter if one is required or installed. (Refer to Section 600 for more detailed information).

(E) Services Supplied from the Downtown Network System:

The point of delivery will be at the point of junction between the CPS Energy cable terminator (load-side of fuse pad, grid-tied disconnect or grid-tied fuse pad) and Customer's service conductors.

(F) Primary Voltage Service - Overhead:

The point of delivery will be at the load-side terminals of the CPS Energy primary metering equipment.

(G) Primary Voltage Service - Underground:

The point of delivery will be in a metering compartment within Customer's switchgear or switchboard, or in a separate primary meter enclosure.

(H) Primary Voltage Cable to High-Rise Residential Buildings:

When CPS Energy owned primary voltage cable serves transformer vaults with transformers supplying secondary voltage service to grouped or individual

SECTION - 100 DEFINITIONS

meters, the point of delivery will be in the transformer vault or room at the secondary spades of the transformer. All CPS Energy owned conductors shall be effectively outside the building (Refer to Definition of "Conductors Considered Outside of Building")

Point of Interconnection:

The point where the Distributed Generation (DG) itself is electrically connected, either directly to the CPS Energy system or to the load side (metered) of the Customer owned equipment for the applicable DG system.

Portable:

A structure that by design is manufactured with the purpose and intent of being moved from one location to another. Manufactured homes installed on permanent foundations are still by design, structures that may be re-located from one site to another.

Raceway:

An enclosed channel of metal or nonmetallic materials designed expressly for holding wires, cables, or busbars, with additional functions as permitted by the NEC. Raceways include, but are not limited to, rigid metal conduit (RMC), rigid polyvinyl chloride conduit (PVC), intermediate metal conduit (IMC), electrical metallic tubing (EMT), surface raceways, wireways, and busways (Refer to Definition of Service Raceway).

Raintight:

Constructed or protected so that exposure to a beating rain will not result in the entrance of water under specified test conditions.

Reactive Power:

Reactive power is power that flows back and forth between the inductive windings of the generator and the inductive windings of motors, transformers, etc., which are part of the electrical load. This power does no useful work in the electrical load nor does it present load to the engine. It does apply load to the generator and limits the capacity of the generator.

Real Power:

Real power is the product of current, voltage, and power factor (the cosine of the angle by which current leads or lags voltage) and is expressed as W (watts).

Seal:

A special padlock or a breakable sealing device installed by CPS Energy on metering equipment and on enclosures located on the line-side of meters. Only CPS Energy personnel are authorized to possess, install, remove, or break CPS Energy seals and locks.

Service Conductors:

The conductors from the service point to the service disconnecting means.

Service Drop:

The overhead service conductors extending from CPS Energy's overhead distribution system to the point of delivery location. The connection is made by CPS Energy to the Customer's service-entrance conductors at the building or other structure.

SECTION - 100 DEFINITIONS

"Triplex" or "Quadraplex" cables are used for most service drops and consist of one bare neutral and two or three insulated aluminum conductors. Larger service drops consist of three or four ethylene propylene rubber (EPR) insulated copper conductors. They may be installed either 'open' (Moused) where each phase conductor is separate and attached to the structure or building separately, or 'cabled' (bundled) where all phase conductors are twisted together and attached to the building or structure at one point.

Service-Entrance Conductors:

On overhead systems, the service conductors between the terminals of the service equipment and a point usually outside the building, clear of building walls, where joined by tap or splice to the service drop.

On underground systems, the conductors between the terminals of the service equipment and the point of connection to the service lateral.

Note 1: Where service equipment is located outside the building walls, there may be no service-entrance conductors, or they may be entirely outside the building.

Note 2: Service-entrance conductors including grounded conductors installed within or ahead of CPS Energy metering equipment shall be insulated.

Service Equipment:

The necessary equipment, usually consisting of a circuit breaker(s) or switch(es) and fuse(s), and their accessories, connected to the load end of service conductors to a building or other structure, or an otherwise designated area, and intended to constitute the main control and cutoff of the supply.

Service Head:

The service head shall be an approved raintight type, properly sized to accommodate the service raceway and service-entrance conductors. It should be positioned within 12 to 24 inches from the anchorage point of the service drop to allow the bottom of the drip loop to comply with minimum clearances specified in Section 500 and shown in Figure 500.1.

Service Lateral:

The underground service conductors between the utility source, including conductors from any risers at a pole or other structure or from padmount transformers, and the first point of connection to the service-entrance conductors in a terminal box, meter or other enclosure inside or outside the building wall.

Note 1: Service lateral conductors including grounded conductors installed within or ahead of CPS Energy metering equipment shall be insulated.

Service Raceway:

The raceway(s) that contains service conductors including service lateral conductors and service-entrance conductors.

Above Ground:

Raceway as used herein for aboveground installations shall be limited to, galvanized rigid metal conduit (RMC), intermediate metal conduit (IMC),

SECTION - 100 DEFINITIONS

electrical metallic tubing (EMT), and busways. The specific raceway types permitted will be as specified in the applicable section of these standards.

Exception: *Where a tap box is approved by CPS Energy in accordance with Section 1000, a throated metal wireway without removable covers shall be furnished by Customer to be used between transformer and tap box.*

Below Ground:

Raceway as used herein for underground installations shall be limited to, galvanized rigid metal conduit (RMC), intermediate metal conduit (IMC), and rigid polyvinyl chloride conduit (PVC) (Schedule 40 and 80 PVC). The specific raceway types permitted will be as specified in the applicable section of these standards.

Note: Junction boxes and/or conduit bodies are not permitted as part of raceway installations containing service conductors.

Shall, Must or Will:

These terms signify mandatory compliance with the provisions outlined in the CPS Energy's Electric Service Standards.

Supply Facilities:

All facilities including the service drops or laterals and meter, together with auxiliary devices and poles, if any, owned and installed by CPS Energy used to connect CPS Energy's electric supply lines to Customer's installation.

CPS Energy will install and maintain the electric supply lines and service installations on CPS Energy's side of the point of delivery. CPS Energy shall not be required to install or maintain any facilities or devices except meters, on Customer's side of the point of delivery.

Supply Lines:

Those conductors used by CPS Energy to transmit electric energy and their necessary supporting or containing structures.

Transfer Switch:

A transfer switch is an electrical device for switching loads between alternate power sources. An automatic transfer switch monitors the condition of the sources and connects the load to the alternate source if the preferred source fails.

Transformer Room:

An approved space within Customer's building or structure for housing CPS Energy owned distribution transformers that supply electric service to Customer's premises. Transformer rooms shall be designed and built by Customer in accordance with NEC and CPS Energy standards and be suitable for the purpose intended.

Transformer Vault:

An approved space for housing CPS Energy owned distribution transformers that supply electric service to Customer's premises. Transformer vaults shall be designed and built by CPS Energy or Customer in accordance with NEC and CPS Energy standards and be suitable for the purpose intended.

Transocket:

A single enclosure containing instrument transformer rated metering equipment that includes meter socket, current transformers, voltage transformers (if required), and test switch. Where the current limitations of a self-contained meter socket are exceeded, a transocket may be installed as standard equipment for applications of 480 volts or less.

Underground Residential Distribution (URD) System:

Those residential areas in the Overhead Distribution District that are served from an isolated underground type electric system.

Voltage Dip:

Voltage dip is the dip in voltage that results when a load is added, occurring before the regulator can correct it, or resulting from the functioning of the voltage regulator to unload an overloaded engine generator.

Voltage, Nominal:

A nominal value assigned to a circuit or system for the purpose of conveniently designating its voltage class (e.g. 240/120-volts, 480Y/277-volt, 600 volts, etc.). The actual voltage that a circuit operates can vary from the nominal value within a range that permits satisfactory operation of equipment.

Note: See ANSI C84.1-1995, Voltage Ratings for Electric Power Systems and Equipment (60 Hz).

Voltage Regulation:

Voltage regulation is a measure that states the difference between maximum and minimum steady-state voltage as a percentage of nominal voltage.

Watertight:

Constructed so that moisture will not enter the enclosure under specified test conditions.

Watt:

The watt is a unit of electric power. In direct current (DC) circuits, wattage equals voltage times amperage. In alternating current (AC) circuits, wattage equals effective (RMS) voltage times effective (RMS) amperage times power factor times a constant dependent on the number of phases. 1,000 watts equal one kW.

Weatherproof:

Constructed or protected so that exposure to the weather will not interfere with successful operation.

SECTION 200

CHARACTERISTICS, TYPES AND AVAILABILITY OF ELECTRIC SERVICE

CHARACTERISTICS, TYPES AND AVAILABILITY OF ELECTRIC SERVICE



201 Characteristics of Service:

The electric service supplied by CPS Energy is alternating current with a nominal frequency of 60 Hertz.

202 Types of Electric Service, Overhead and Underground Distribution:

202.1 Secondary Voltage Service for Lighting and Appliances (Single-Phase):

The standard single-phase nominal voltage at a point of delivery is 120/240-volts supplied by a three-wire, grounded neutral service.

Note: A 120/208-volt, single-phase, three-wire, grounded neutral system may be made available for individually metered loads in multiple occupancy buildings. These loads must be supplied from a 208Y/120-volt, three-phase, four-wire service and be balanced (Refer to Section 1800).

202.2 Secondary Voltage Service for Expressway Lighting (Single-Phase):

The standard single-phase nominal voltage for expressway lighting systems is 240/480-volts supplied by a three-wire, grounded neutral service. This service voltage is only available for expressway lighting systems. These systems are generally not metered. For any systems that are metered, the rules that govern 480Y/277-volt self-contained metered services as outlined in Sections 400 and 1800 shall apply.

202.3 Secondary Voltage Service for Combination Power and Lights (Single-Phase and Three-Phase):

The standard service connection for three-phase loads or a combination of single-phase and three-phase loads is a 4-wire wye with a grounded neutral. The standard nominal voltage at a point of delivery is 208Y/120-volt or 480Y/277-volt. Customers must have a demand load of 25 kVA or greater for 208Y/120-volt service and 45 kVA or greater for 480Y/277-volt service.

Note 1: A four-wire, grounded neutral 240/120-volt open-delta service is normally available but only for loads which can be served from a pole mounted transformer bank. The minimum three-phase load requirement for this service is a 7.5 horsepower motor, and the maximum load is that which can be served from two 100 kVA pole mounted transformers. The largest three-phase motor shall not exceed 60 horsepower.

Note 2: A 240/120-volt three-phase, closed-delta service for new service requests is not permitted.

Note 3: For added load to an existing three-phase 240/120-volt closed-delta service, Customer will have to coordinate with CPS Energy's Customer Service Representative. Where the load exceeds the pole mounted transformer bank rating, CPS Energy engineering will review and determine if load can be served from a closed-delta padmount transformer. Should CPS Energy determine that it is not feasible to supply with a padmount transformer, Customer shall be responsible for changing their service voltage to either 208Y/120-volt or 480Y/277-volt in order to accommodate their added load.

Exception: In no case will CPS Energy install closed-delta transformers (padmount or pole mounted) that must be energized from the 34.5 kV primary distribution systems.

202.4 Primary Voltage Service (Single-Phase):

Service may be supplied at the following nominal primary voltages upon prior approval of CPS Energy:

- (1) 2400 volt, two-wire, (minimum load required, 20 kVA)
- (2) 7620 volt, two-wire, (minimum load required, 70 kVA)
- (3) 19920 volt, two-wire, (minimum load required, 175 kVA)

202.5 Primary Voltage Service (Three-Phase):

Service may be supplied at the following nominal primary voltages upon prior approval of CPS Energy.

- (1) 4160Y/2400-volt, four-wire, (minimum load required, 60 kVA)
- (2) 13200Y/7620-volt, four-wire, (minimum load required, 200 kVA)
- (3) 34500Y/19920-volt, four-wire, (minimum load required, 500 kVA)

Note: Primary voltage services with loads less than the minimums listed above may be permitted in special cases with approval from CPS Energy's Electric Service and Metering Standards Section. The maximum demand load that may be served from a CPS Energy primary voltage service will be determined on an individual basis by CPS Energy's Distribution Planning Section.

203 Sizing of CPS Energy Transformers:

203.1 Demand Loads through 100 kVA (Single-Phase):

The standard method for supplying single-phase demand loads up to 100 kVA at 120/240-volts is from a pole mounted transformer. CPS Energy will determine the appropriate size transformer installation required to serve the Customer's demand load. If Customer requests a larger transformer size than that specified by CPS Energy, Customer will be responsible for the additional cost. Additionally, if Customer requests a padmount transformer when the demand load is less than 100 kVA, then Customer will be responsible for the additional cost.

203.2 Demand Loads over 100 kVA (Single-Phase):

The standard method for supplying single-phase demand loads greater than 100 kVA is with padmount transformers. CPS Energy will determine the appropriate size transformer installation required to serve the Customer's demand load. If Customer requests a larger transformer size than that specified by CPS Energy, Customer will be responsible for the additional cost.

203.3 Demand Loads through 300 kVA (Three-Phase Grounded Wye):

The standard method for supplying three-phase grounded wye demand loads up to 300 kVA is from pole mounted transformer banks. CPS Energy will determine the appropriate size transformer installation required to serve the Customer's demand load. If Customer requests a larger transformer size than that specified by CPS Energy, Customer will be responsible for the additional cost. Additionally, if Customer requests a padmount transformer when the

demand load is less than 300 kVA, then Customer will be responsible for the additional cost.

Exception: *In areas designated for underground systems where overhead systems are not available or are not permitted, CPS Energy will provide padmount transformer service at no additional cost to Customer for demand loads less than 300 kVA.*

203.4 Demand Loads over 300 kVA (Three-Phase Grounded Wye):

The standard method for supplying three-phase grounded wye demand loads greater than 300 kVA is with padmount transformers. CPS Energy will determine the appropriate size transformer installation required to serve the Customer's demand load. Where Customer requests a larger transformer size than that specified by CPS Energy, Customer will be responsible for the additional cost.

203.5 Maximum Demand Load Served at a Single Point of Delivery with One Standard Size Padmount Transformer (480 Volts and Less):

- (1) 480Y/277-volt service-2500 kVA
- (2) 208Y/120-volt service-1000 kVA
- (3) 120/240-volt single-phase service-250 kVA

Where Customer's demand load is larger than what can be served with one standard-size transformer, CPS Energy may install additional transformers as necessary.

203.6 Electric Services Supplied by Multiple Transformers:

Multiple transformers may be required to service Customer load requirements or where Customer requests transformer redundancy. Where multiple transformers are installed, the transformer's service laterals shall be installed as individual service laterals to serve individual units of Customer service equipment. Specific provisions for each of these types of installation are outlined in (A) and (B) below.

Note 1: *Customer shall coordinate with the CPS Energy Customer Service Representative to determine whether or not Customer's demand load can be served with single or multiple transformers.*

Note 2: *Customer equipment with a normally open tie-breaker and individual bus bar sections are considered as individual units for the purpose of this article.*

Note 3: *Serving individual units of Customer service equipment will reduce fault current availability to the Customer.*

(A) Multiple Transformers Required for Load Capacity:

Where Customer's load capacity requires multiple transformers, installation shall be as outlined below:

- (1) Each transformer must be supplied by the same primary distribution circuit.

- (2) Each transformer service lateral shall terminate on an individual bus within Customer service equipment.
- (3) Each transformer service lateral must be installed in accordance with the provisions of the NEC and other applicable codes.
- (4) Transformers shall be located such that the distance between transformers does not exceed 40 feet center to center.

Note: *CPS Energy will not install parallel transformers serving equipment with a common secondary bus.*

Note: *Grouping Customer's individual units of service equipment will eliminate the requirement of having to construct a fire barrier separating the areas served by each (Refer to Article 207).*

(B) Multiple Transformers Required for Redundancy:

Where Customer's service design proposes transformer redundancy, installation shall be as outlined below:

- (1) Each transformer service lateral shall terminate on individual bus within Customer service equipment.

Note: *CPS Energy will not install parallel transformers serving equipment with a common secondary bus.*

- (2) Each transformer service lateral must be installed in accordance with the provisions of the NEC and other applicable codes.
- (3) Transformers shall be located such that the distance between transformers does not exceed 40 feet center to center.

Note: *Grouping Customer's individual units of service equipment will eliminate the requirement of having to construct a fire barrier and separating the areas served by each (Refer to Article 207).*

204 Availability of Electric Service to Non-Residential Customers from an Underground Residential Distribution System:

Electric service to non-residential Customers from an existing Underground Residential Distribution (URD) system may be available. Customer should consult with the CPS Energy Customer Service Representative for service availability prior to proceeding with any property investments or service designs.

205 Types of Electric Service and Demand Loads from Downtown Network System:

A majority of the San Antonio Central Business District is served from the Downtown Network System that is separate and isolated from the rest of the electric distribution system due to its unique design. This system is totally underground and consists of multiple parallel circuits on the primary and secondary sides of the system. Service requirements from the Downtown Network System are outlined generally below and covered in more detail in Section 1100.

205.1 Secondary Voltage Service for Combination Power and Lights:

The standard nominal voltage at a point of delivery is 208Y/120-volts from a four-wire, three-phase grounded wye service. With approval from CPS Energy's Network Engineering Section, a 480Y/277-volt three-phase service voltage or a 120/208-volt single-phase service voltage, may be supplied. If approval is granted for a 480Y/277-volt three-phase service, a Customer built transformer vault or room on or immediately adjacent to Customer's premises will be required (Refer to Section 1100).

205.2 Demand Loads:

Load serving capability on the Downtown Network System is determined on an individual basis and depends on vault or network grid design limitations. Prior consultation to determine service availability should be conducted with the CPS Energy Customer Service Representative (Refer to Section 1100).

206 Number of Services:

CPS Energy will supply service at one point, through one meter, at one voltage class under its rate schedules, rules, and regulations.

A building, other structure or property served shall be supplied by only one service unless otherwise approved by CPS Energy in accordance with Article 206.1 below (Refer to Definition of "Building").

Note 1: CPS Energy will not supply a building with an additional service where CPS Energy supply facilities are capable of supplying Customer's total load at one service location. CPS Energy reserves the right to make final determination on the supply of additional services.

Note 2: A service lateral, whether from a CPS Energy transformer, or approved tap box, shall be considered the same as a separate service for the purposes of these Standards.

206.1 Additional Services:

Where CPS Energy deems it necessary to supply a building or structure with an additional service in accordance with one of the limited conditions outlined in (A) through (D) below, such installation shall also comply with the specific provisions outlined in Article 207.

Note: In all cases, CPS Energy and the respective Authority Having Jurisdiction (AHJ) must be in agreement. CPS Energy will make final determination on the supply of additional services.

(A) Special Conditions:

- (1) Fire pumps that are legally required in accordance with the NEC and applicable codes.
- (2) Redundant service installations approved by CPS Energy where designed for the purposes of enhanced reliability.

Note: CPS Energy will review all other special condition requests for additional services on a case by case basis.

(B) Special Occupancies:

- (1) Multiple occupancy buildings where there is no available space for service equipment accessible to all occupants as determined by CPS Energy and the respective AHJ.
- (2) Commercial buildings whose length equals or exceeds 300 feet and whose services are located a minimum of 300 feet apart.
- (3) Residential apartment buildings whose length equals or exceeds 100 feet and whose services are located a minimum of 100 feet apart.
- (4) Residential properties where buildings or structures are separated by a minimum of 300 feet and the services will be located a minimum of 300 feet apart.

(C) Capacity Requirements:

- (1) Residential apartment buildings where the Customer's service equipment exceeds a rating of 1600 amperes. Services may be located on opposite ends of the building or can be grouped in the same location.
- (2) Where Customer demand loads exceed what can be served by one CPS Energy standard size padmount transformer (Refer to Article 203.6).
- (3) Other instances where CPS Energy deems it necessary to supply the building or structure with a separate service in order to handle Customer demand loads.

(D) Different Characteristics:

- (1) Where a load must be served at a different voltage, phase, or rate class as determined by CPS Energy.

207 Separate Services Supplied:

Where separate services are permitted in accordance with Article 206, Customer shall be required to comply with the provisions of Article 207.1 and 207.2 below.

207.1 Permanent Plaque or Directory:

A permanent plaque or directory shall be installed at each service disconnect location denoting all other services or feeders supplying the building or structure, and the area served by each.

207.2 Fire Barrier Separation:

A minimum two-hour fire barrier is required to separate the areas served by each service. The fire barrier rating and construction shall be based on the building codes adopted by the City of San Antonio, even in those locations outside the San Antonio city limits (Refer to Definition of "Fire Barrier"). Electrical wiring in buildings with multiple services shall not cross the fire barrier. The respective AHJ shall enforce this requirement.

Exception 1: Fire barrier will not be required where an additional service is permitted by CPS Energy to supply legally required fire pumps.

Exception 2: *Fire barrier will not be required where separate services are permitted in accordance with Article 206.1 and all service disconnecting means can be grouped together in a manner approved by CPS Energy. In no case shall grouped service disconnects exceed six handles.*

208 One Building or Other Structure Not to Be Supplied Through Another or From an Adjacent Property:

CPS Energy owned service lateral conductors and/or unmetered Customer owned service lateral conductors supplying a building or other structure shall not pass through the interior or beneath another building or other structure.

CPS Energy will not supply services with proposed designs that have Customer-owned distribution attached to buildings on separately platted properties that are designed to cross property lines.

Property owner with an existing service seeking to replat the property will be required to contact their CPS Energy Customer Service Representative for a new service. Customer owned service conductors are not permitted to cross property lines even when properties are owned by the same Customer.

209 Metering:

All service taken at the same point of delivery will be metered with one meter, or in the case of multiple occupancy buildings, with grouped meters. Additional services permitted in accordance with Article 206.1 may have separate meters as approved by CPS Energy.

209.1 Metering Equipment:

CPS Energy no longer provides single-phase, self-contained meter sockets to electrical contractors. Single-phase, self-contained meter sockets approved by CPS Energy are listed on Figure 1800.1 and may be purchased through local distributors. CPS Energy will continue to provide standard metering equipment such as: self-contained, three-phase meter sockets; transformer rated, three-phase meter sockets; instrument transformers; and standard instrument transformer enclosures at no cost to the Customer. Any requests for non-standard metering equipment will be evaluated by CPS Energy, and if approved, must be furnished and installed by Customer at Customer's expense (Refer to Section 1800 and Table 1800.1).

209.2 Totalized Metering:

Where it is necessary for CPS Energy to supply service with more than one transformer in accordance with Article 203.6, and those transformers are located such that the maximum metering control cable length from each transformer does not exceed 20 feet, CPS Energy may provide totalized metering. If the transformers are located together and totalized metering is approved, additional Customer expenses may apply (Refer to Section 1800).

Note: *Where multiple transformers are installed to supply Customer's demand load, and the transformers are not located together, separate meters will be installed and metering will not be totalized.*

209.3 Metering Location for Service Conductors:

CPS Energy requires that service conductors be metered before entering in or being routed underneath the building or structure being supplied.

Exception: CPS Energy will review proposed designs where special circumstances may require the use of meter rooms within the building for location of multiple metering equipment. Where CPS Energy approves such designs, Customer shall be responsible for that portion of the service lateral conduit(s) under the building or structure. Service conduit(s) shall be installed as required to be considered outside of the building and shall terminate within 4 feet upon entering a CPS Energy approved electric meter room. CPS Energy may require Customer to install spare conduits and to locate meter rooms on exterior walls as close as possible to the transformer poles (Refer to Definition of "Conductors Considered Outside of Building").

SECTION 300

USE OF ELECTRIC SERVICE



USE OF ELECTRIC SERVICE



301 General:

CPS Energy operates its electric distribution system with the highest degree of care and safety for the public and its employees. Sound engineering standards and policies developed by CPS Energy along with the National Electric Safety Code (NESC) are used for design, construction, maintenance, and operation of the electric distribution system by CPS Energy. The most current edition of the NESC at the time of installation will apply unless otherwise specified by CPS Energy.

302 Continuity of Service:

CPS Energy's electric transmission and distribution systems experience disruptions and disturbances due to weather, animals, and other external influences. Therefore, CPS Energy does not guarantee its service voltage against irregularities or interruptions. CPS Energy is not liable to Customer for any damage to their electrical equipment or other property that may result from exposure to irregularities or interruptions.

302.1 Equipment Protection:

Customer is responsible for protecting their equipment against overcurrent, unbalanced load, unbalanced voltage, single-phasing conditions, overvoltage, undervoltage, lightning surges, and any other irregularities or disturbances.

302.2 Rated for Available Fault Current:

Customer's service-entrance equipment must be designed for the fault current that may be available from CPS Energy's electric distribution system. Customer should contact CPS Energy's Customer Service representative to obtain fault current availability for its supply source.

303 Load Balancing and Voltage Drop:

Customer shall balance their load at the point of delivery. Where Customer owned conductors are installed on the line-side of CPS Energy metering equipment, they shall be of sufficient capacity to limit voltage drop to 2.5 percent of nominal service voltage. Factors to be considered are maximum calculated load of circuit, load power factor, length of circuit from source to metering equipment, type of conductors, and the type of conduit. Conductor sizes shall be approved by CPS Energy.

304 Interference:

Customer shall contact CPS Energy's Customer Service Representative for proper coordination when installing equipment, such as large motors, that may create disturbances on CPS Energy's distribution system. CPS Energy may require the installation of corrective equipment to limit the interference that would otherwise be caused by Customer's equipment. Corrective equipment will be furnished and installed by Customer at Customer's expense as a requirement for receiving electric service.

Where CPS Energy deems it necessary to install corrective equipment on its supply facilities to limit the adverse effects of Customer's equipment, the installation may be at Customer's expense. Any equipment installed by CPS Energy to minimize interference may also be used to serve other Customers. To eliminate undesirable effects caused by the operation of Customer's equipment, the Customer's equipment shall be installed in accordance with the provisions outlined in Article 304.1 through 304.3 below.

304.1 Voltage Flicker:

Equipment operation shall not cause excessive voltage flicker on CPS Energy's system and shall not exceed 3 percent voltage dip at the point of common coupling in accordance with the Institute of Electrical and Electronics Engineers IEEE 1543 (Refer to Definitions of "Point of Common Coupling" and "Voltage Dip").

304.2 Harmonic Distortion:

Equipment operation shall not result in a total harmonic distortion (THD) of greater than 5 percent of the fundamental 60Hz frequency nor 3 percent of the fundamental frequency of any individual harmonic measured at the point of delivery in accordance with IEEE 519 (Refer to Definition of "Harmonic Distortion").

304.3 Motors:

Starting currents for large motors may result in excessive voltage sags on the CPS Energy electric distribution system. These sags affect all Customers connected to the same circuit and, therefore, must be limited to an acceptable level. All services involving motors of 100-horsepower or larger will require review and approval from CPS Energy. The levels of voltage sag will be evaluated by CPS Energy based on the motor's starting current, frequency of motor starting, the characteristics of CPS Energy's distribution circuit(s), and any other relevant factors. Where CPS Energy determines that the proposed motor loads will result in excessive voltage sag on the CPS Energy distribution circuit(s), Customer will be required to furnish and install, at their expense, all devices and/or equipment, such as soft-start equipment needed to limit the adverse effects of motor loads to levels acceptable to CPS Energy.

All Motors greater than 10-horsepower and less than 100-horsepower shall be equipped with means to limit the instantaneous starting current to approximately 300 percent of rated full load current.

Motors greater than 100-horsepower shall require review by CPS Energy's Distribution Planning to determine appropriate provisions for motor starting currents.

Exception: *Motors rated between 10 and 25-horsepower that do not start up more than 4 times per hour.*

305 Induced Current in Metal Enclosures:

Customer should be aware that alternating current produces magnetic fields that may cause noise and heat in ferrous metal enclosures and take all necessary precautions to minimize those effects on the equipment installed.

306 Interconnection of Power Sources on Customer Side of Point of Delivery or to CPS Energy's Distribution System:

306.1 Emergency Power Systems:

Emergency electric generators or auxiliary power supplies owned by Customer shall not operate in parallel with CPS Energy's lines or equipment unless specifically approved by Distribution Planning (Refer to Definition of "Parallel Operation").

Customer shall provide the transfer scheme, control schematics, and operating logic for review by CPS Energy's Electric Service and Metering Standards Section. The transfer scheme shall be interlocked to prevent paralleling normal utility power and emergency power sources during normal, test, and maintenance conditions, unless approved otherwise by CPS Energy.

306.2 Interconnected Distributed Generation:

Distributed Generation (DG) is normally installed for one of two business purposes. The business purposes are known as either Net-Metering or Grid-Tied as outlined below:

(A) Net-Metering:

A net meter measures the difference between the amount of energy the DG Facility generates and the amount of energy CPS Energy supplies. The point of interconnection is in the Customer service equipment on the load-side of the Customer's revenue meter. The Customer must also be the DG Facility owner.

(B) Grid-Tied:

A DG Facility designed with the sole purpose to sell all its generated net power to CPS Energy under a power purchase agreement or tariff. The DG Facility is connected to CPS Energy's distribution system at a location and in a manner approved by CPS Energy.

CPS Energy encourages both purposes pursuant to completing the appropriate application and submittal of installation design in compliance with the technical interconnection guidelines established by CPS Energy (Refer to Definition of "Distributed Generation").

All required applications and technical guidelines can be found in the DG Manual available online at www.cpsenergy.com.

Note: *No DG Facility shall be operated in parallel with CPS Energy facilities without first meeting all application, plan review, and field commissioning requirements, and obtaining express written consent from CPS Energy.*

SECTION 400

SERVICE EQUIPMENT



401 General:

This section covers installation requirements for service conductors and equipment used for control and protection of services. This section also contains specific disconnecting means requirements for self-contained meter sockets associated with 480Y/277-volt service and Distributed Generation (DG) Systems.

402 Service-Entrance Conductors:

Generally, only one set of service-entrance conductors can be supplied from a service lateral or service drop. Where additional sets of service-entrance conductors permitted by exceptions in the National Electrical Code (NEC) for multi-occupancy type buildings are installed from an auxiliary gutter ahead of CPS Energy metering equipment, the metering equipment and tenant service disconnects shall be grouped and located immediately adjacent to the gutter. The total number of service disconnecting means shall be in accordance with the NEC and Article 406 (Refer to Definition of "Service-Entrance Conductors").

Note 1: Customer shall use nipples to connect metering equipment and tenant service disconnects to gutter. Where special circumstances require the use of lengths more than a nipple, CPS Energy shall first approve such installation and Customer shall install service-entrance conductors in RMC or IMC conduits and limit the distance to as short as possible.

Note 2: CPS Energy does not permit multiple sets of service-entrance conductors to be connected directly to the service drop.

Note 3: Service-entrance conductors including the grounded conductor shall be insulated. Conductor insulation shall be a type approved by the NEC.

Note 4: CPS Energy will not permit feeder or branch circuit conductors to be installed in auxiliary gutters or wireways containing service-entrance conductors.

403 Service Disconnecting Equipment:

Customer shall provide means to disconnect all conductors in a building or other structure from the service or service-entrance conductors. The service disconnecting means shall be installed in accordance with the NEC and applicable codes (Refer to Definition of "Service Equipment").

403.1 Suitable for Use as Service Equipment:

Service equipment rated 600 volts or less shall be marked to identify it as being suitable for use as service equipment and shall be listed (Refer to Definition of "Listed").

403.2 Suitable for Use Conditions:

Each service disconnecting means shall be suitable for the prevailing conditions. Service equipment installed in hazardous (classified) locations shall comply with the specific requirements of the NEC.

403.3 Available Short-Circuit Current:

Equipment shall be capable of handling the maximum fault current available at its supply terminals in accordance with the NEC. Equipment is required to be marked with the maximum available fault current. Customer shall

SECTION 400 - SERVICE EQUIPMENT

coordinate with CPS Energy's Customer Service Representative to obtain available fault current information.

403.4 Working Space:

In no case shall the workspace in the vicinity of electrical service equipment be less than that required by the NEC and not less than that required in Section 1800 for metering equipment.

403.5 Bonding of Service Equipment:

The non-current carrying metal parts of service equipment shall be bonded in accordance with the NEC and applicable codes. Each service shall be grounded in accordance with the NEC and other applicable codes (Refer to Section 1700).

403.6 Grounded Conductor Brought to Each Service Disconnect:

Where an electrical system operating at less than 1000 volts is grounded at any point, the grounded conductor(s) shall be sized per the NEC and be routed with the ungrounded conductors to each service disconnecting means grounded conductor(s) or terminal bus. A main bonding jumper shall connect the grounded conductor(s) to each service disconnecting enclosure.

Exception: Where more than one service disconnecting means is located in a single assembly listed for use as service equipment, it shall be permitted to connect the grounded conductor(s) to the assembly common grounded conductor(s) or terminal bus. Assembly shall include a main bonding jumper for connecting the grounded conductor(s) to the assembly enclosure.

403.7 Identification Marking:

Service disconnecting means shall be permanently marked to identify it as a service disconnect. Where a building is supplied by more than one service, a permanent plaque or directory shall be installed at each service disconnect location denoting the other service(s).

403.8 Equipment Connected to Supply-Side of Service Disconnect:

Connections permitted by the NEC to be made on the supply side of the service disconnect shall not be made by splicing or tapping within the service disconnect.

Exception: Surge protection and/or current limiting devices.

404 Means of Identifying Grounded and Ungrounded Conductors:

CPS Energy requires grounded and ungrounded conductors to be identified as described below.

404.1 Grounded Conductors:

Customer shall clearly and permanently identify the grounded (neutral) conductor(s) before CPS Energy installs service.

(A) Sizes No. 8 AWG or Smaller:

An insulated grounded conductor of No. 8 AWG or smaller shall be identified by a continuous white or gray outer finish along its entire length on other than green insulation along its entire length.

(B) Sizes Larger than No. 8 AWG:

An insulated grounded conductor larger than No.8 AWG shall be identified either by a continuous white or gray outer finish or on other than green insulation along its entire length, or at the time of installation by a distinctive white marking at its terminations. Such white marking shall remain readily visible after termination of conductors at service.

404.2 Means of Identifying Ungrounded Conductors:

Ungrounded conductors shall be distinctively marked as shown below to identify phasing and voltage but shall not have insulation colors of white, natural gray or green.

(A) Within CPS Energy Metering Equipment:

For proper identification and safe operation of CPS Energy metering equipment, the conductors within CPS Energy metering equipment shall be distinctively marked at their terminations as follows unless otherwise specified by CPS Energy:

Color of Ungrounded Conductor

<u>Type of Service</u>	<u>Phase A</u>	<u>Phase B</u>	<u>Phase C</u>
208Y/120-volt	black	red	blue
480Y/277-volt	purple	brown	yellow
240Δ/120-volt	blue	black	orange (hi-leg) (See 404.2(B) Below)

(B) Within Customer Service Equipment:

When identifying ungrounded conductors in Customer service equipment, identification as shown for metering equipment above would apply with the exception that the hi-leg conductor shall be connected as the center leg in all Customer service equipment (Refer to Section 1800 and Figure 1800.8).

Note: Where conductors are marked as shown above, CPS Energy will connect service for A-B-C phase rotation (clockwise indication on a phase sequence indicator). This color code applies to all three-phase services, overhead or underground. Permanent plaque and/or labeling to indicate this termination within metering equipment enclosures will be required.

405 Location of Customer Service Disconnecting Equipment:

The Customer owned service disconnecting means shall be installed in accordance with requirements established in the NEC and other applicable codes and shall meet the specific provisions outlined by CPS Energy in 405.1 through 405.3 below:

405.1 Readily Accessible Location:

The service disconnecting means shall be installed at a readily accessible location either outside of a building or structure or inside nearest the point of entrance of the service conductors.

Exception 1: One and two family dwellings shall have the service disconnecting means located on the outside of building at the CPS Energy approved meter location (Refer to Section 700).

Exception 2: Multifamily dwellings including apartments shall have the service disconnecting means located on the outside of building at the CPS Energy approved meter location (Refer to Section 800).

Exception 3: Buildings or structures supplied by CPS Energy from an overhead or an overhead to underground service, shall have the service disconnecting means located on the outside of building or structure at the CPS Energy approved meter location (Refer to Section 500 and 600).

Exception 4: Mobile homes and/or manufactured homes shall have the service disconnecting means located on a meter pole (overhead supply) or meter pedestal (underground supply) adjacent to the home and not mounted in or on the home (Refer to Section 1500).

Exception 5: Temporary or portable type buildings or structures shall have the service disconnecting means located on a meter pole (overhead supply) or meter pedestal (underground supply) adjacent to and not mounted in or on the building or structure (Refer to Definition of "Portable" and Section 1400).

405.2 Height of Operating Handles:

The grip center of the service disconnecting means operating handle shall not be more than 6 feet 7 inches above floor or working platform.

405.3 Remote Control:

Where a remote control device(s) is used to actuate the service disconnecting means, the service disconnecting means shall be required to be located in accordance with the provisions of the NEC and applicable codes including this Section.

406 Maximum Number of Disconnects:

The service disconnecting means for each service permitted by the NEC and in accordance with the limited special conditions outlined by CPS Energy in Section 200, shall consist of not more than six switches or sets of circuit breakers, or a combination thereof mounted in a single enclosure, in a group of separate enclosures or in a switchboard.

Exception: Disconnecting means installed as part of listed equipment and used solely for the following shall not be considered a service disconnecting means:

- (1) Power monitoring equipment
- (2) Surge protective device(s)
- (3) Control circuit of the ground-fault protection system
- (4) Power operable service disconnecting means

407 Grouping of Disconnects:

The multiple disconnects permitted by the NEC and Article 405 (up to six) shall be grouped. Each disconnect shall be marked to indicate the load served.

407.1 Additional Service Disconnecting Means (Fire Pump):

The one or more additional service disconnecting means permitted by the NEC and Section 200 for fire pumps, and with special permission, for emergency systems, legally required standby, or optional standby systems shall be installed remote from the one to six service disconnecting means for normal service to minimize the possibility of simultaneous interruption of supply.

Note: Metering equipment for fire pump shall be grouped adjacent to other metering equipment associated with the building service and permanently labeled as fire pump metering equipment.

407.2 Main Disconnecting Device:

Where a main disconnecting device is installed with grouped meters or is required because of more than six disconnects, it shall be located immediately adjacent to the meters. Where a main disconnecting means is located ahead of CPS Energy metering equipment, it shall be locked and sealed by CPS Energy.

407.3 Identification:

Service disconnecting means shall be permanently marked to identify it as a service disconnect. Where a building or structure is supplied by more than one service, a permanent plaque or directory shall be installed at each service disconnect location denoting all other services (Refer to Sections 200 and 1800).

408 Meter Disconnects for Self-Contained 480Y/277-volt Meters:

On 480Y/277-volt services having estimated demand or calculated loads of 200 amperes or less (166 kVA or less), CPS Energy will furnish 200 ampere, self-contained meter sockets (Refer to Figure 1800.2). Customer shall furnish and install a 480Y/277-volt rated meter disconnect switch on the line-side of, and in the same location as the meter socket. The meter disconnect switch shall be labeled permanently as "Meter Disconnect" and not be utilized as a switching device for Customer loads or take the place of Customer's service disconnecting means required by the NEC and applicable codes on the load-side of the meter socket.

408.1 Meter Disconnect Rating:

The meter disconnect switch nominally rated not in excess of 600 volts shall be non-fused for installations with available short-circuit current ratings of 10,000 amps or less and be listed as suitable for service equipment.

408.2 Sealing of Meter Disconnects:

Meter disconnects ahead of 480Y/277-volt self-contained meters shall be sealed by CPS Energy to the extent necessary to protect unmetered conductors. Personnel requiring access to the interior of the meter disconnect switch shall first notify CPS Energy.

408.3 Customer Service Disconnecting Means:

Customer shall install a service disconnect in accordance with the NEC and this Section of the standards on load-side of 480Y/277-volt self-contained meters. Service disconnecting means shall be grouped with meter and meter disconnect switch (Refer to Definition of "Meter Disconnect Switch").

408.4 Provisions for Existing Services:

Where upgrades and/or modifications to existing services are necessary and those existing services are not provided with meter disconnects as required herein, Customer shall be required to comply with the provisions applicable as outlined below:

- (1) On single meter installations where self-contained meter sockets are installed, Customer shall be required to bring service up to current standards by installing a meter disconnect ahead of self-contained meter socket.
- (2) On multiple meter installations where space is available and metering and service equipment can be installed to meet height requirements outlined in the NEC and these standards, Customer shall install newly added meter loops to current standards. Existing meter loops may remain as currently found provided they are deemed to be in safe condition by CPS Energy.

Note: CPS Energy reserves the right to make final determination on whether or not meter loops will be required to be installed to current standards.

409 Meter Disconnects for Distributed Generation:

On all Distributed Generation (DG) Systems, a meter disconnect switch shall be installed ahead of CPS Energy's kWh meter to isolate it from the DG power source. The meter disconnect switch shall be located immediately adjacent to the meter (Refer to Section 2000).

410 Service Raceway Types Permitted:

Service lateral and service-entrance conductors shall be installed in accordance with the NEC and other applicable codes and shall be limited to installation in the raceway type specified in the applicable respective Section of these Standards (Refer to Definition of "Service Raceway").

Note: Junction boxes and/or conduit bodies are not permitted as part of raceway installations containing service conductors.

411 Raceway Seal:

Where service raceways enter a building or structure from an underground distribution system and moisture can enter through them to contact live parts, they shall be sealed or plugged at either or both ends. Spare or unused raceways shall also be sealed. Sealants shall be identified for use with the cable insulation, shield or other components.

412 Downtown Network System:

Customer service disconnecting means for services supplied from CPS Energy's Downtown Network System shall be located and installed in accordance with the specific provisions outlined in Section 1100. Customer may contact the CPS Energy Customer Service Representative for the geographical boundaries of the Downtown Network System and to review service options from the Downtown Network System (Refer to Section 1100).

SECTION 500

OVERHEAD SERVICES (SERVICE DROPS UNDER 600 VOLTS)



OVERHEAD SERVICES
(SERVICE DROPS UNDER 600 VOLTS)



501 General:

An overhead service consists of overhead secondary voltage service conductors from a CPS Energy distribution pole to a Customer owned building or structure, or meter pole. CPS Energy metering equipment will be installed at this location.

501.1 Aesthetic Design Areas:

In areas where overhead service drops are prohibited for aesthetic reasons, CPS Energy will supply with overhead to underground service laterals or from padmount transformers.

501.2 Overhead-to-Underground Conversion Areas:

Overhead services are not available in areas that have been converted from overhead primary distribution to underground primary distribution. Only underground services will be allowed in these areas.

501.3 Underground Distribution Areas:

Overhead services are not available in underground distribution areas such as the South Texas Medical Center, Hemisfair Park, and other underground commercial developments. Only underground services will be allowed in these areas.

501.4 Downtown Network System:

Overhead services are not available in the area served by the Downtown Network System, which is generally in the San Antonio Central Business District. Only underground services will be allowed from the Downtown Network System. Customer may contact the CPS Energy Customer Service Representative for the geographical boundaries of the Downtown Network System and to review service options from the Downtown Network System (Refer to Section 1100).

502 Vertical Clearances:

Service drop conductors, including drip loops, shall comply with minimum clearance requirements of the NEC and NESC and with the specific provisions herein for services not exceeding 600 volts nominal (Refer to Figure 500.1).

502.1 Above Roofs:

Where service-drop conductors must be installed above a building or structure's roof, the service-drop conductors shall be provided with the minimum vertical clearances shown in Figure 500.1. The vertical clearance above the roof shall be maintained for a distance of not less than 5 feet in all directions from the edge of the roof.

Note: Customer shall coordinate with the CPS Energy Customer Service Representative where temporary or permanent structures are to be constructed or placed under existing CPS Energy service-drop conductors. Customer will be responsible for costs associated with clearance poles if minimum requirements of Figure 500.1 are not maintained.

502.2 Above Final Grade:

Service drop conductors and drip loops, where not in excess of 600 volts nominal shall be installed in accordance with the minimum vertical clearances from final grade, or any other platform or standing surface, as shown in Figure 500.1.

Note: *Customer shall install service head 12 inches above the minimum height clearances required in Figure 500.1 to allow for proper connection of service drop conductors and forming of drip loop by CPS Energy.*

502.3 Above Swimming Pools and Similar:

Swimming pools, hot tubs, spas or any other recreational body of water shall not be placed under existing service-drop conductors, nor shall service drop conductors be installed above these types of installations without meeting the minimum vertical and horizontal clearances outlined by CPS Energy in Figure 500.8.

503 Clearances on Buildings from Final Span of Service Drop Conductors:

Where permanent attachment of service drop conductors to a building is necessary for connection to Customer's service-entrance conductors, the final span of service drop conductors shall be installed to meet the following requirements over or along the installation to which the conductors are attached.

503.1 Windows, Doors, Porches, Balconies, etc.:

Service drop conductors and drip loops shall have a horizontal clearance of not less than 5 feet from doors, porches, balconies, ladders, stairs, fire escapes, windows that are designed to be opened or other similar locations.

503.2 Platforms, Projections and Similar Surfaces:

The vertical clearance of final spans of service drop conductors and drip loops above or within 5 feet measured horizontally from platforms, projections, or surfaces from which they might be reached shall be maintained in accordance with Article 502.3 and Figure 500.1.

503.3 Building Openings:

Service drop conductors or drip loops shall not be installed beneath openings through which materials may be moved, such as openings in farm and commercial buildings, and shall not be installed where they obstruct entrance to these building openings.

504 Length:

The maximum length of unsupported service drop conductors is determined by CPS Energy based on the wire size, weight, sag, and tension on the anchor points. Service drop conductors greater than 1/0 AWG may require the use of one or more clearance poles for support. Demand load may limit service-drop conductor length due to voltage drop limitations specified by CPS Energy (Refer to Section 300).

505 Point of Attachment:

The point of attachment of service drop conductors to a building or other structure shall provide the minimum clearances as specified in Articles 502 and 503 and as shown in Figure 500.1. In no case shall this point of attachment be more than 30 feet nor less than 12 feet above finished grade unless otherwise approved by CPS Energy.

Attachments to building walls shall be made such that the horizontal angle between the service drop conductors and the building wall shall be a minimum of 45 degrees. The point of attachment for the service drop conductors shall be so located as to be accessible from a ladder placed firmly on the ground and against the building.

505.1 Location:

The point of attachment for the service drop conductors shall be located on the building service mast or other structure at the nearest practical point to CPS Energy's supply pole.

Exception: Clearance poles may be used to extend service drop conductor distances where approved and deemed necessary by the CPS Energy Customer Service Representative.

505.2 Means of Attachment:

There are various types of hardware used to anchor the service-drop conductors to the building or other structure depending on the type, size, and weight of the conductors. Typical anchoring options and related information are outlined in (1) through (4) below:

- (1) On service-drops such as for residences and small commercial occupancies, a clamp-on type eyebolt for service masts, or a screw type eyebolt for wood structures may be used. CPS Energy installs the anchor during the service drop installation. Customer shall furnish the anchors if the CPS Energy standard type anchor cannot be used.
- (2) On larger service drops, Customer must furnish and install 5/8-inch galvanized all-thread machine bolts for installation in the building or structure during construction, especially for buildings of concrete, masonry, or brick construction. The machine bolts with galvanized washer and nut must be installed by the Customer and protrude 2 inches outside the building wall. CPS Energy will install a clevis and insulator on these bolts when the service drop is installed.
- (3) Anchorage must be designed to withstand 750 pounds of load tension induced from the weight of the service drop conductors. Open (moused) service drops will require an anchor for each conductor. Cabled (bundled) service drops will require only one anchor. Customer must consult with the CPS Energy Customer Service Representative to determine the type of service drop required (Refer to Figures 500.6 and 500.7).
- (4) Where a building is not tall enough to provide anchorage to meet the required clearances, the service raceway may be extended vertically from the metering or service equipment and serve the dual purpose of enclosing the service-entrance conductors and supporting the service drop conductors. CPS Energy will furnish and install a raceway clamp with eyebolt to support the service drop conductors. Service raceways so installed shall meet the requirements for service masts outlined in Article 507 and shown in Figures 500.3 through 500.5.

506 Service Raceway:

The service raceway(s) containing the service-entrance conductors shall be installed in a manner that will ensure proper clearances for the service drop conductors and drip loop in accordance with this Section.

506.1 Location:

Service raceways shall be installed on the outside of the building or structure and be continuous except for couplings. Couplings or fittings

shall be listed and provide no access to unmetered conductors (Refer to Definition of "Listed").

506.2 Approved Types:

Service raceways enclosing service-entrance conductors shall be galvanized rigid metal conduit (RMC), intermediate metal conduit (IMC) or electrical metallic tubing *(EMT) type raceways.

Exception 1: **EMT is not permitted where used as a service mast.*

Exception 2: *Bussed risers are permitted where service-entrance conductors exceed three conductors per phase (Refer to Article 509.5).*

506.3 Size:

The size of service raceways shall be as specified by the NEC and other applicable codes but in no case be less than 1 1/4-inch.

Exception No. 1: *Service raceways used as service masts shall be 2 inches, minimum, RMC or IMC.*

Exception No. 2: *On meter sockets, the size of the service raceway shall be the same size as the hub. On meter sockets with 1 1/4-inch hub that will be used with a service mast riser, the meter socket shall be upgraded to accommodate a 2-inch hub.*

506.4 Number of Conduits:

The number of service raceways permitted to be connected to CPS Energy approved meter sockets and enclosures shall be in accordance with Table 1800.1 and Figure 1800.1. Each conduit shall have the same physical characteristics and contain one each of the ungrounded (phase) and neutral conductors. Where three conductors per phase are insufficient, a bussed service head must be used (Refer to Article 509.5).

Note: *Paralleling of service-entrance conductors in a single conduit is not permitted.*

507 Service Masts:

Where service drop conductor clearances as specified in Article 502 and 503 and shown in Figure 500.1 cannot be obtained by standard anchorage, then a service mast must be used. This type of installation consists of extending the service raceway, through the eaves if necessary, and anchoring the service-drop conductors on the service mast (Refer to Figure 500.3).

507.1 Adequate Strength:

The service mast must withstand the strain imposed on it by the service drop conductors. Conduit used for service masts shall be 2 inches (minimum) and shall be rigid metal conduit (RMC) or intermediate metal conduit (IMC), with no coupling between the roof line and service head. The service mast, or any other service raceway, shall not be used to support other equipment.

507.2 Rise Above Roof:

Where a service mast rises above a roof or roof parapet, it shall extend beyond that point a minimum of 36 inches and maximum of 60 inches measured

to the top of the conduit. The service mast must be designed to withstand 750 pounds of load tension induced from the service drop conductors.

507.3 Roof Penetrations:

The point where a service mast emerges through a roof shall be weatherproof and utilize approved flashing plates and associated hardware including sealing materials. Roof flashing plate shall be installed in accordance with manufacturer's instructions and as shown in Figure 500.3.

507.4 Support of Service Mast:

Where service raceways are used for the support of service drop conductors, they shall be supported in accordance with the respective figure indicated below:

- (1) Service mast for overhead residential single-phase services shall be supported in accordance with Figure 500.3.
- (2) Service masts for overhead commercial three-phase services without overhead CT's shall be supported in accordance with Figure 500.4.
- (3) Service masts for overhead commercial three-phase services with overhead CT's shall be supported in accordance with Figures 500.5, 500.6 and 500.7.

508 Service Head:

The service head shall be an approved raintight type properly sized to accommodate the service raceway and service-entrance conductors. It should be positioned within 12 to 24 inches from the anchorage point of the service-drop conductors to allow the bottom of the drip loop to comply with minimum clearances specified in Articles 502 and 503 and shown in Figure 500.1.

509 Service-Entrance Conductors:

The service-entrance conductors shall be furnished and installed by Customer for connection to CPS Energy's service drop conductors. Conductors shall be installed to meet minimum requirements of the NEC and other applicable codes and the provisions outlined herein.

509.1 Size:

Service-entrance conductors shall have sufficient ampacity to carry the load as determined by the NEC and other applicable codes, and in no case, be smaller than No. 8 AWG copper or No. 6 AWG aluminum. Service-entrance conductor sizes shall not exceed those specified by CPS Energy for meter sockets or other CPS Energy metering equipment (Refer to Section 1800).

509.2 Conductor Insulation:

Service-entrance conductors including grounded conductors entering or on the exterior of buildings or other structures shall be insulated. Conductor insulation must be a type approved by the NEC and other applicable codes for the use intended.

509.3 Connectors, Terminals, and Taps:

The service drop conductors shall be connected by CPS Energy to the service-entrance conductors by means of compression or mechanical connectors furnished by CPS Energy. CPS Energy will not permit connectors, terminals

or taps to be connected to the service-entrance conductors ahead of metering equipment.

Exception 1: *Where Customer installs a bussed service head in accordance with Article 509.5, the Customer shall furnish and install approved connectors for connection to CPS Energy service drop conductors.*

Exception 2: *Where connectors are used to join the service drop conductors and service-entrance conductors.*

Exception 3: *Where connections within metering equipment are used to close the meter loop.*

Exception 4: *Where taps are used within auxiliary gutters or junction boxes required by CPS Energy to energize metering equipment from service lateral or service-entrance conductors.*

509.4 Paralleled Conductors:

Aluminum, copper-clad aluminum, or copper conductors for each phase, neutral or grounded circuit shall be permitted to be connected in parallel (electrically joined at both ends to form a single conductor) only in sizes 1/0 AWG and larger where installed in accordance with (1) through (5) below:

- (1) Be the same length.
- (2) Have the same conductor material.
- (3) Be the same size in circular-mil area.
- (4) Have the same insulation type.
- (5) Be terminated in the same manner.

509.5 Maximum Number of Conductors:

CPS Energy will connect service drop conductors directly to service-entrance conductors where paralleled service-entrance conductors per phase at the service head do not exceed three conductors.

- (1) Where three paralleled service-entrance conductors per phase are used, each cable shall not exceed 500 KCM aluminum or 500 KCM copper.
- (2) Where two paralleled service-entrance conductors per phase are used, each cable shall not exceed 750 KCM aluminum or 500 KCM copper.

Note: *Where more than three paralleled service-entrance conductors per phase are used, a bussed service head approved by CPS Energy shall be furnished and installed by Customer.*

509.6 Exposed Conductors for Connections:

CPS Energy requires 24 inches minimum of free wire ends extending from the service head (except bussed type) for making connections to the service-drop conductors.

On the line-side and load-side of metering equipment, Customer must provide sufficient wire ends for forming wire and making necessary connections to close meter loops. Where window-type CT's are installed in enclosures, CPS Energy will work with Customer in pulling their conductors through the CT's thereby avoiding connections. Ample conductor slack shall be provided for training and forming conductors (Refer to Section 1800 and Figure 1800.13).

509.7 Means of Identifying Grounded and Ungrounded Conductors:

Customer shall clearly and permanently identify grounded (neutral) and ungrounded (phase) conductors before CPS Energy installs service (Refer to Section 400 Article 404).

509.8 Minimum Number of Conductors Required Based on Type of Service Supplied:

The minimum number of service-entrance conductors shall be as specified below depending on the type of service (single-phase or three-phase) supplied by CPS Energy.

- (1) Single-phase power and lighting require three conductors: two-ungrounded, one-grounded.
- (2) Three-phase power and lighting require four conductors: three-ungrounded, one-grounded.

509.9 Line and Load Conductors:

Conductors other than service-entrance conductors shall not be in service raceways. Customer load conductors shall not be permitted in any service raceway, junction box or auxiliary gutter installed ahead of CPS Energy metering equipment.

510 Metering:

All metering equipment shall be installed on the exterior of building or structure at a location approved by the CPS Energy Customer Service Representative and in accordance with Section 1800. Customer shall provide CPS Energy an approved space on the building wall or structure for metering equipment.

Note 1: Where space is not available on building wall, Customer shall provide a suitable metering equipment rack separate from building (Refer to Definition of "Metering Equipment Rack" and Figure 1800.20).

Note 2: For Customer calculated loads requiring instrument transformer rated metering equipment, CPS Energy may install instrument transformers at building wall or on service mast where applicable. CPS Energy will furnish transformer mounting bracket (s) (TMB) for installation by Customer (Refer to Figure 500.5, 500.6 and 500.7).

Note 3: Service disconnecting means shall be located in accordance with Section 400 Article 405.

FIGURE 500.1
SERVICE-DROP CLEARANCES, 600 VOLTS OR LESS

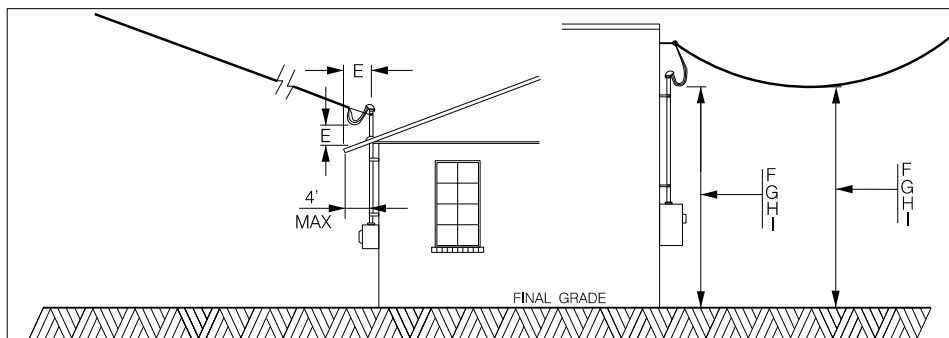

		120/240 VOLTS	208Y/120 VOLTS	240/120 VOLTS	480Y/277 VOLTS
	VERTICAL CLEARANCES ABOVE ROOF				
A	ALL POINTS OF ROOF ABOVE WHICH CONDUCTORS PASS ⁽³⁾	8 FT	8 FT	8 FT	8 FT
B	ROOFS SUBJECT TO PEDESTRIAN TRAFFIC ⁽³⁾	10 FT	10 FT	10 FT	10 FT
C	ROOFS SUBJECT TO VEHICULAR TRAFFIC ⁽³⁾	18 FT	18 FT	18 FT	18 FT
D	ROOFS WITHOUT READY ACCESS TO PEDESTRIANS AND HAVING A PITCH OF 4 INCHES PER FOOT OR GREATER ⁽²⁾⁽³⁾	5 FT	5 FT	5 FT	5 FT
E	ROOFS WITHOUT READY ACCESS TO PEDESTRIANS AND SERVICE-DROP CONDUCTORS WITH MAXIMUM HORIZONTAL DISTANCE OF 6 FT FROM AN APPROVED RACEWAY OR SUPPORT LOCATED NOT MORE THAN 4 FT FROM THE EDGE OF THE ROOF. ⁽¹⁾⁽²⁾⁽³⁾	1 FT 6 IN	1 FT 6 IN	1 FT 6 IN	1 FT 6 IN
	VERTICAL CLEARANCES ABOVE GROUND ,ROADS, ETC.				
F	SPACES AND WAYS SUBJECT TO PEDESTRIANS OR RESTRICTED TRAFFIC ONLY; INCLUDES POINT OF ATTACHMENTS, IF APPLICABLE. ⁽³⁾⁽⁴⁾⁽⁵⁾	12 FT	12 FT	12 FT	12 FT
G	DRIVEWAYS, PARKING LOTS , AND ALLEYS; INCLUDES POINT OF ATTACHMENTS, IF APPLICABLE ⁽³⁾⁽⁶⁾	18 FT	18 FT	18 FT	18 FT
H	ROADS, STREETS, AND OTHER AREAS SUBJECT TO TRUCK ⁽³⁾ TRAFFIC; INCLUDES POINT OF ATTACHMENT, IF APPLICABLE	22 FT	22 FT	22 FT	22 FT
I	OVER TRACKS RAILS OF RAILROADS	24 FT	24 FT	24 FT	24 FT
	OTHER	REFER TO NESC	REFER TO NESC	REFER TO NESC	REFER TO NESC

NOTES

- REMAINDER OF HORIZONTAL DISTANCE TO BE MAINTAINED AT 3 FT AND ONLY APPLICABLE IF ON ROOFS WITHOUT READY ACCESS.
- ROOF,BALCONY,PORCH,OR ATTACHED DECK IS CONSIDERED READILY ACCESSIBLE TO PEDESTRIANS IF IT CAN BE CASUALLY ACCESSED THROUGH A DOORWAY, WINDOW, RAMP, STAIRWAY, OR PERMANENTLY MOUNTED LADDER BY A PERSON, ON FOOT, WHO NEITHER EXERTS EXTRAORDINARY PHYSICAL EFFORT NOR EMPLOYS TOOLS OR DEVICES TO GAIN ENTRY.A PERMANENTLY MOUNTED LADDER IS NOT CONSIDERED A MEANS OF ACCESS IF ITS BOTTOM RUNG IS 8 FT OR MORE ABOVE THE GROUND OR OTHER PERMANENTLY INSTALLED ACCESSIBLE SURFACE.
- MEASUREMENTS APPLY TO DRIP LOOP CONDUCTORS AS WELL AS SERVICE-DROP CONDUCTORS.
- SPACES AND WALKWAYS SUBJECT TO PEDESTRIANS OR RESTRICTED TRAFFIC ONLY ARE THOSE AREAS WHERE RIDERS ON HORSES OR OTHER LARGE ANIMALS, VEHICLES, OR OTHER MOBILE UNITS EXCEEDING A TOTAL HEIGHT OF 8 FT, ARE PROHIBITED BY REGULATION OR PERMANENT TERRAIN CONFIGURATIONS, OR ARE OTHERWISE NOT NORMALLY ENCOUNTERED NOR REASONABLY ANTICIPATED.
- WHERE THE HEIGHT OF A RESIDENTIAL BUILDING DOES NOT PERMIT ITS SERVICE-DROP(S) TO MEET THESE VALUES, THE CLEARANCES MAY BE REDUCED AS FOLLOWS: 150 VOLTS OR LESS TO GROUND – 10 FT FOR BOTH SERVICE-DROP AND DRIP LOOP.
- WHERE THE HEIGHT OF A RESIDENTIAL BUILDING DOES NOT PERMIT ITS SERVICE-DROP(S) TO MEET THESE VALUES, THE CLEARANCES OVER RESIDENTIAL DRIVEWAYS ONLY MAY BE REDUCED AS FOLLOWS: 150 VOLTS OR LESS TO GROUND – 12 FT FOR SERVICE DROP AND FOR 10 FT DRIP LOOP.
- CLEARANCES IN FRONT AND ABOUT METERING AND SERVICE EQUIPMENT SHALL BE IN ACCORDANCE WITH THE NEC AND SECTION 1800 (REFER TO FIGURE 1800.20).
- CUSTOMER SHALL INSTALL TOP OF SERVICE HEAD 12 INCHES ABOVE THE MINIMUM HEIGHT CLEARANCES SHOWN HERE TO ALLOW FOR PROPER CONNECTION OF SERVICE-DROP CONDUCTORS AND FORMING OF DRIP LOOP BY CPS ENERGY.

FIGURE 500.2
OVERHEAD RESIDENTIAL SERVICE, ONE METER

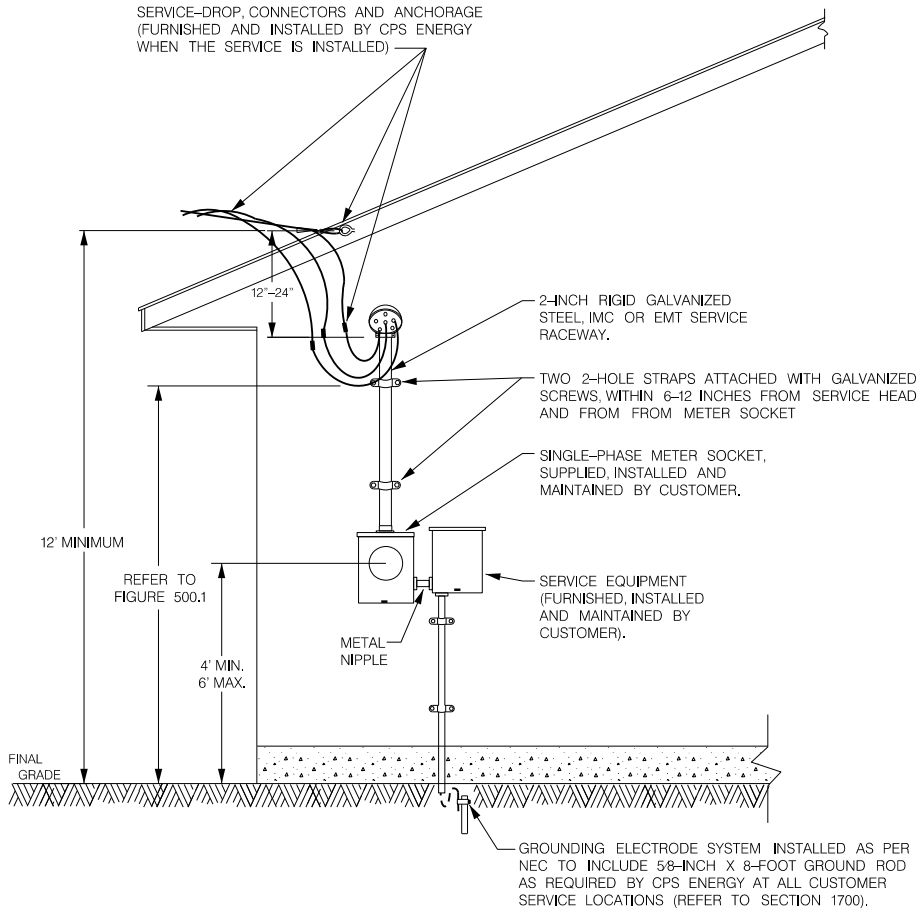

NOTES:

1. SERVICE HEAD AND CONDUIT SHALL BE FURNISHED AND INSTALLED BY CUSTOMER. SERVICE-ENTRANCE CONDUCTORS TO EXTEND A MINIMUM OF 24 INCHES OUTSIDE THE SERVICE HEAD FOR CONNECTION TO SERVICE-DROP.
2. METERING EQUIPMENT SHALL BE LOCATED TOTALLY OUTSIDE OF BUILDING OR STRUCTURE AT CPS ENERGY APPROVED SERVICE-DROP LOCATION.
3. CLEARANCES IN FRONT AND ABOUT METERING AND SERVICE EQUIPMENT SHALL BE IN ACCORDANCE WITH THE NEC AND SECTION 1800 (REFER TO FIGURE 1800.21).
4. CUSTOMER SHALL INSTALL TOP OF SERVICE HEAD 12 INCHES ABOVE THE MINIMUM HEIGHT CLEARANCES SHOWN HERE TO ALLOW FOR PROPER CONNECTION OF SERVICE-DROP CONDUCTORS AND FORMING OF DRIP LOOP BY CPS ENERGY.

FIGURE 500.3
OVERHEAD RESIDENTIAL SERVICE, ONE METER WITH A SERVICE MAST

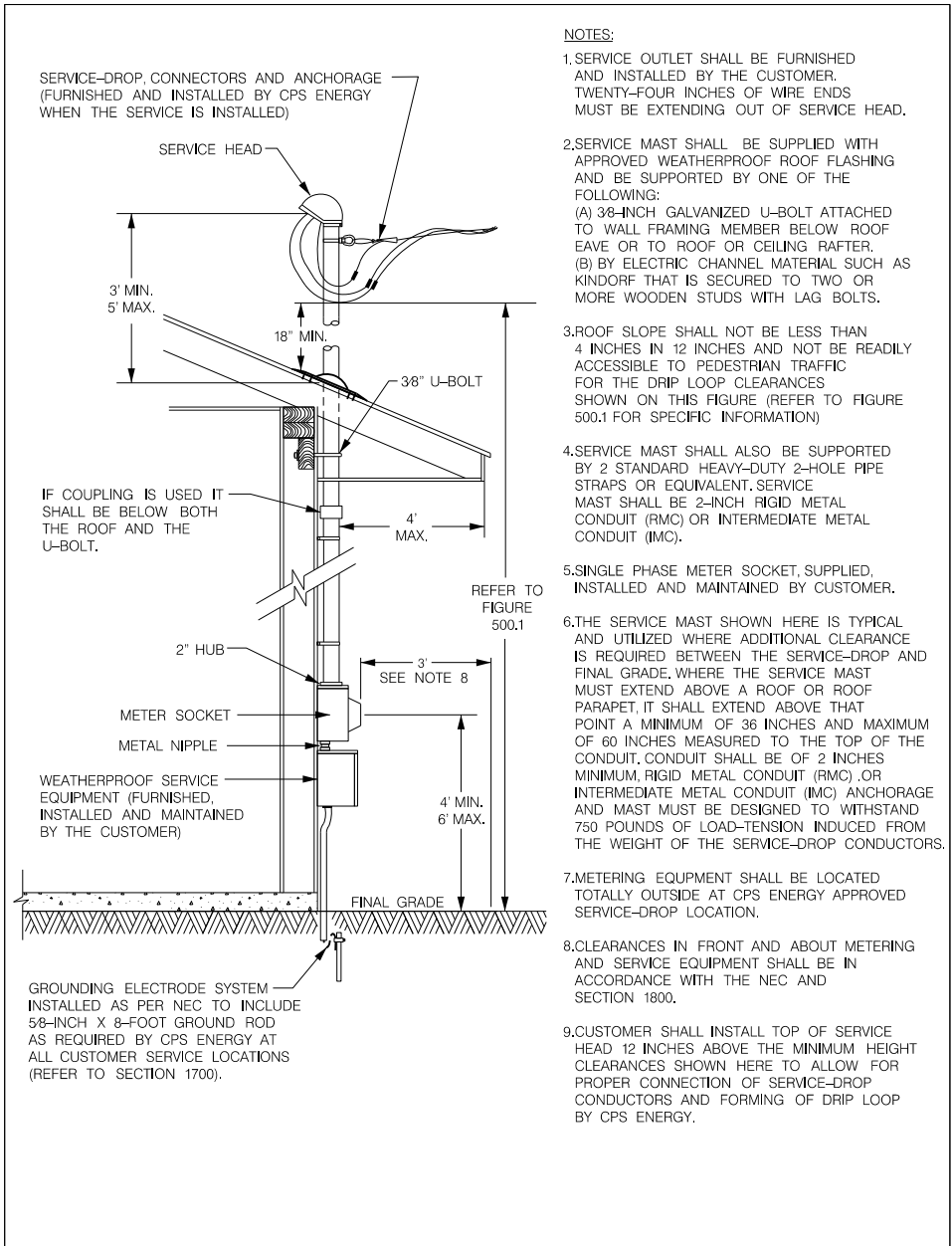

- NOTES:**
- SERVICE OUTLET SHALL BE FURNISHED AND INSTALLED BY THE CUSTOMER. TWENTY-FOUR INCHES OF WIRE ENDS MUST BE EXTENDING OUT OF SERVICE HEAD.
 - SERVICE MAST SHALL BE SUPPLIED WITH APPROVED WEATHERPROOF ROOF FLASHING AND BE SUPPORTED BY ONE OF THE FOLLOWING:
 - 3/8-INCH GALVANIZED U-BOLT ATTACHED TO WALL FRAMING MEMBER BELOW ROOF EAVE OR TO ROOF OR CEILING RAFTER.
 - BY ELECTRIC CHANNEL MATERIAL SUCH AS KINDORF THAT IS SECURED TO TWO OR MORE WOODEN STUDS WITH LAG BOLTS.
 - ROOF SLOPE SHALL NOT BE LESS THAN 4 INCHES IN 12 INCHES AND NOT BE READILY ACCESSIBLE TO PEDESTRIAN TRAFFIC FOR THE DRIP LOOP CLEARANCES SHOWN ON THIS FIGURE (REFER TO FIGURE 500.1 FOR SPECIFIC INFORMATION)
 - SERVICE MAST SHALL ALSO BE SUPPORTED BY 2 STANDARD HEAVY-DUTY 2-HOLE PIPE STRAPS OR EQUIVALENT. SERVICE MAST SHALL BE 2-INCH RIGID METAL CONDUIT (RMC) OR INTERMEDIATE METAL CONDUIT (IMC).
 - SINGLE PHASE METER SOCKET, SUPPLIED, INSTALLED AND MAINTAINED BY CUSTOMER.
 - THE SERVICE MAST SHOWN HERE IS TYPICAL AND UTILIZED WHERE ADDITIONAL CLEARANCE IS REQUIRED BETWEEN THE SERVICE-DROP AND FINAL GRADE, WHERE THE SERVICE MAST MUST EXTEND ABOVE A ROOF OR ROOF PARAPET, IT SHALL EXTEND ABOVE THAT POINT A MINIMUM OF 36 INCHES AND MAXIMUM OF 60 INCHES MEASURED TO THE TOP OF THE CONDUIT, CONDUIT SHALL BE OF 2 INCHES MINIMUM, RIGID METAL CONDUIT (RMC) OR INTERMEDIATE METAL CONDUIT (IMC) ANCHORAGE AND MAST MUST BE DESIGNED TO WITHSTAND 750 POUNDS OF LOAD-TENSION INDUCED FROM THE WEIGHT OF THE SERVICE-DROP CONDUCTORS.
 - METERING EQUIPMENT SHALL BE LOCATED TOTALLY OUTSIDE AT CPS ENERGY APPROVED SERVICE-DROP LOCATION.
 - CLEARANCES IN FRONT AND ABOUT METERING AND SERVICE EQUIPMENT SHALL BE IN ACCORDANCE WITH THE NEC AND SECTION 1800.
 - CUSTOMER SHALL INSTALL TOP OF SERVICE HEAD 12 INCHES ABOVE THE MINIMUM HEIGHT CLEARANCES SHOWN HERE TO ALLOW FOR PROPER CONNECTION OF SERVICE-DROP CONDUCTORS AND FORMING OF DRIP LOOP BY CPS ENERGY.

FIGURE 500.4
OVERHEAD SERVICE, THREE-PHASE METER WITH A SERVICE MAST

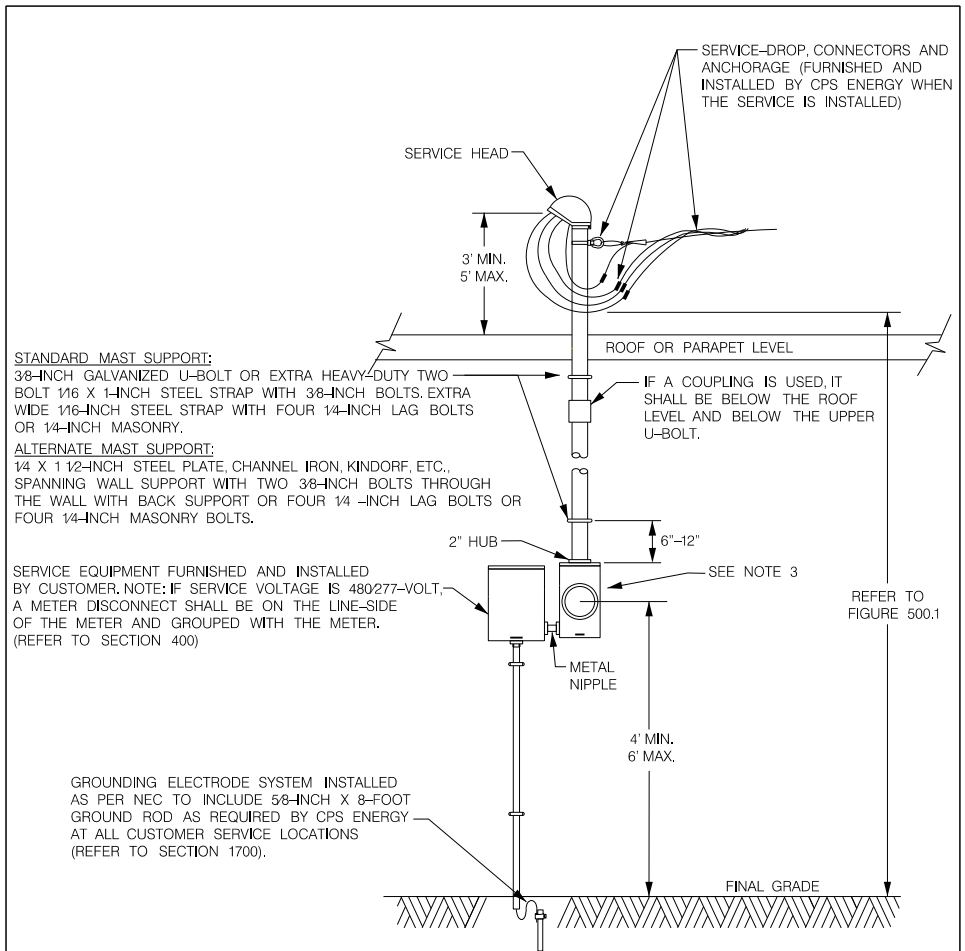

NOTES:

1. THE SERVICE MAST SHOWN HERE IS USUALLY INSTALLED WHERE ADDITIONAL CLEARANCE IS REQUIRED BETWEEN THE SERVICE-DROP AND FINISHED GRADE. THE SERVICE MAST SHALL BE OF 2 INCHES MINIMUM, RIGID METAL CONDUIT (RMC) OR INTERMEDIATE METAL CONDUIT (IMC). IF IT MUST EXTEND ABOVE A ROOF OR ROOF PARAPET, IT SHALL EXTEND ABOVE THAT POINT A MINIMUM OF 36 INCHES AND A MAXIMUM OF 60 INCHES (5 FT) MEASURED TO THE TOP OF THE CONDUIT.
2. ANCHORAGE AND MAST MUST BE DESIGNED TO WITHSTAND 750 POUNDS OF LOAD-TENSION INDUCED FROM THE WEIGHT OF THE SERVICE-DROP CONDUCTORS.
3. CLEARANCES IN FRONT AND ABOUT METERING AND SERVICE EQUIPMENT SHALL BE IN ACCORDANCE WITH THE NEC AND SECTION 1800 (REFER TO FIGURE 1800.21).
4. CUSTOMER SHALL INSTALL TOP OF SERVICE HEAD 12 INCHES ABOVE THE MINIMUM HEIGHT CLEARANCES SHOWN HERE TO ALLOW FOR PROPER CONNECTION OF SERVICE-DROP CONDUCTORS AND FORMING OF DRIP LOOP BY CPS ENERGY.

FIGURE 500.5
OVERHEAD SERVICE, WEATHERPROOF CT'S ON A SERVICE MAST

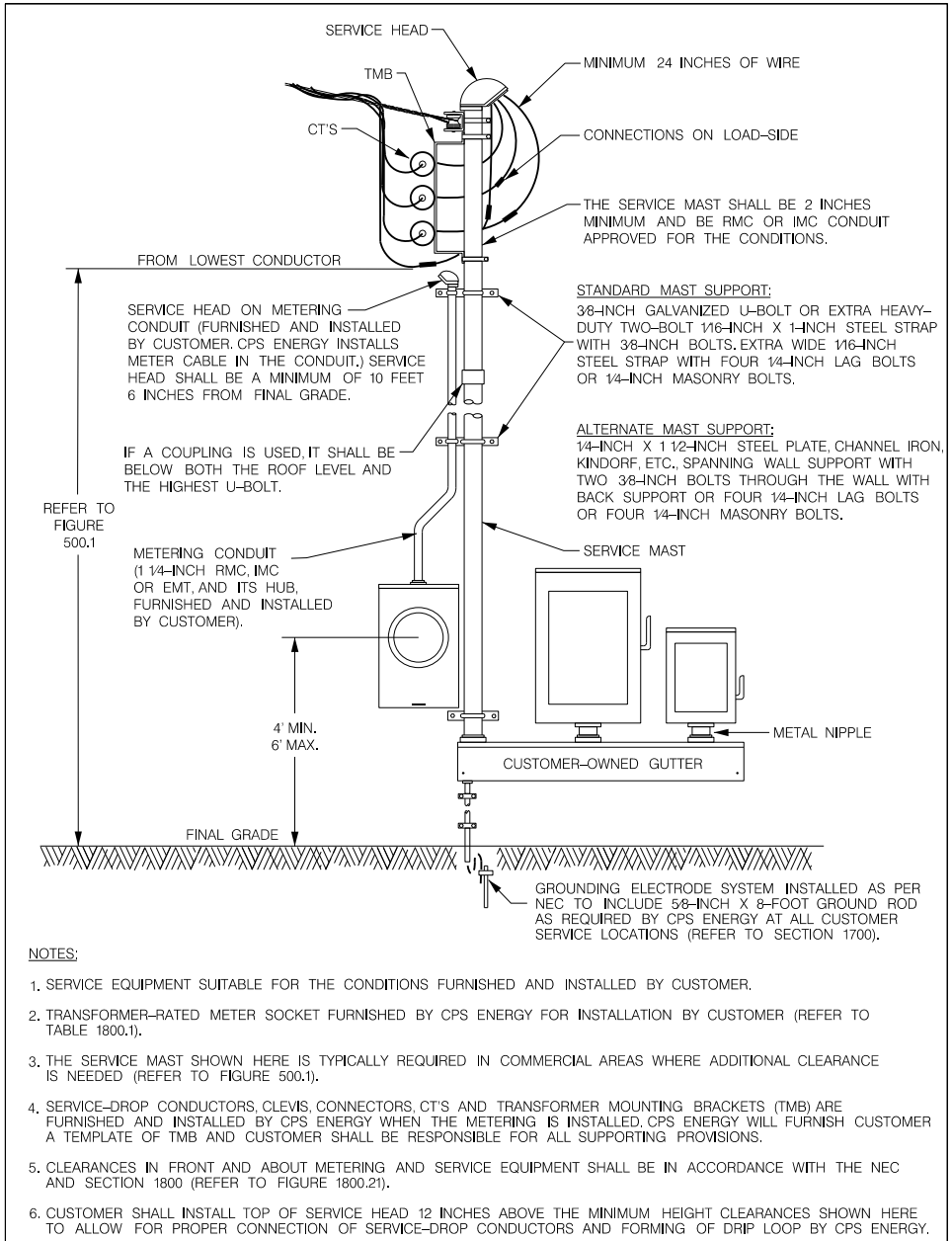
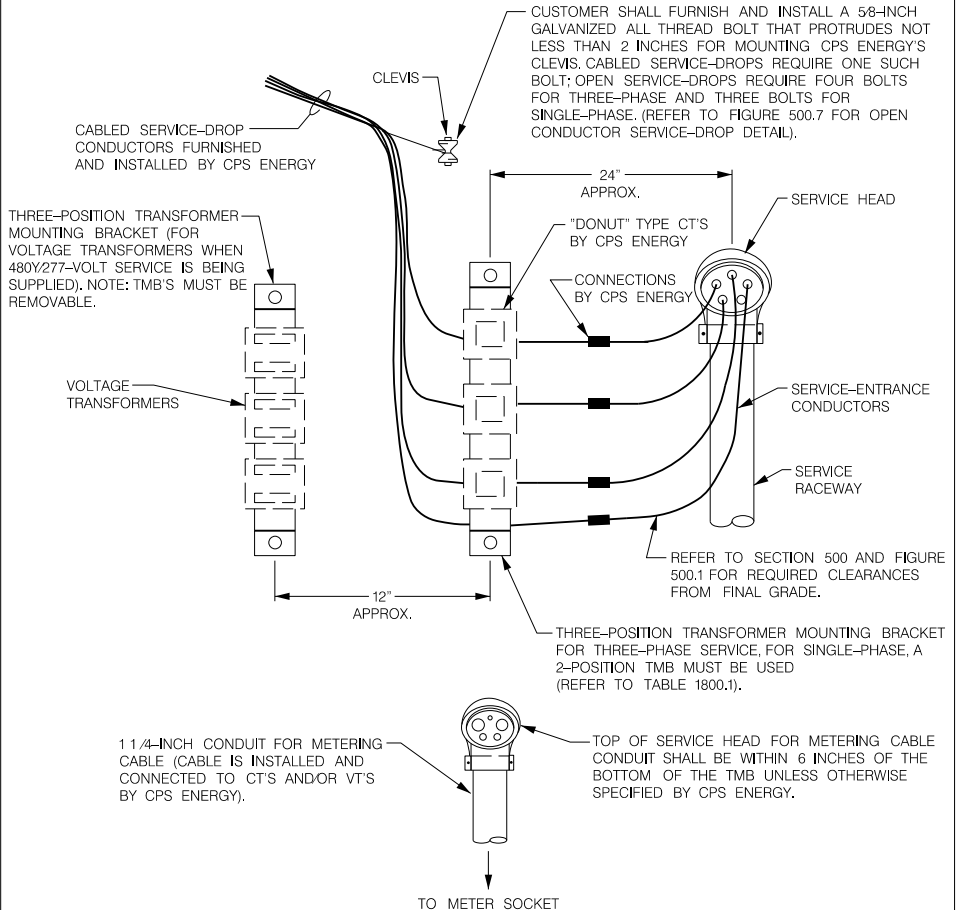

FIGURE 500.6
TYPICAL WALL-MOUNTED WEATHERPROOF TYPE CURRENT AND/OR
VOLTAGE TRANSFORMER INSTALLATION (CABLED SERVICE-DROP)



NOTES:

1. WHERE ONLY ONE CUSTOMER IS TO BE SERVED FROM A SERVICE-DROP AND THE CONNECTED LOAD REQUIRES THE USE OF CT'S AND OR VT'S IN ACCORDANCE WITH SECTION 1800, CPS ENERGY WILL FURNISH THE TRANSFORMER MOUNTING BRACKETS FOR INSTALLATION BY CUSTOMER. CUSTOMER INSTALLS THE TRANSFORMER MOUNTING BRACKETS AS A TEMPLATE FOR CPS ENERGY. CPS ENERGY WILL INSTALL THE CT'S AND OR VT'S AND CONNECT THEM TO THE METER THIS IS DONE WHEN THE SERVICE-DROP IS INSTALLED.
2. THE ABOVE DRAWING IS FOR A TYPICAL CT /VT, SERVICE-DROP INSTALLATION WHERE A CABLED SET OF SERVICE-DROP CONDUCTORS IS USED. WHERE CUSTOMER INSTALLS PARALLELED SERVICE-ENTRANCE CONDUCTORS, OR WHERE CPS ENERGY INSTALLS OPEN SERVICE-DROP CONDUCTORS, OTHER CONFIGURATIONS FOR THE ANCHORAGE AND TRANSFORMER-MOUNTING BRACKETS WILL BE REQUIRED (REFER TO FIGURE 500.7).
3. CUSTOMER FURNISHES AND INSTALLS THE 1 1/4-INCH METERING CONDUIT AND SERVICE HEAD. CUSTOMER IS ADVISED TO CLOSELY COORDINATE THIS TYPE OF INSTALLATION WITH CPS ENERGY'S CUSTOMER SERVICE REPRESENTATIVE.

FIGURE 500.7
 TYPICAL WALL-MOUNTED WEATHERPROOF TYPE CURRENT
 TRANSFORMER INSTALLATION (PARALLELED OR OPEN CONDUCTOR SERVICE-DROP)

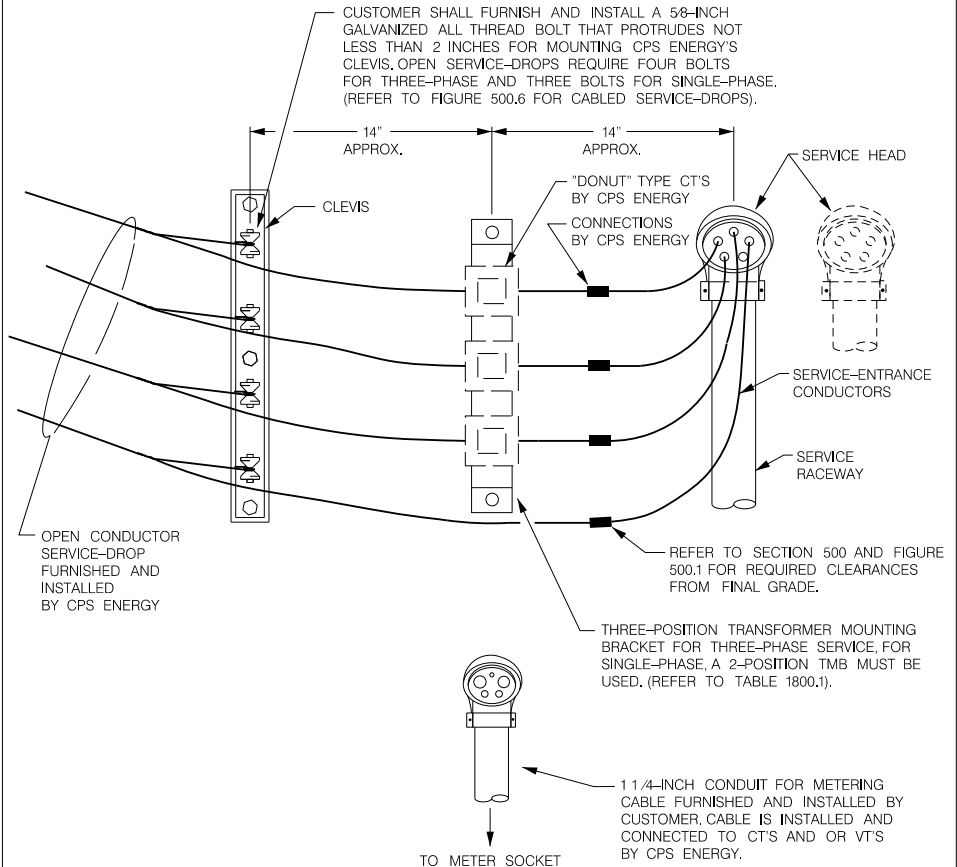

NOTES:

1. WHERE ONLY ONE CUSTOMER IS TO BE SERVED FROM A SERVICE-DROP AND THE CONNECTED LOAD REQUIRES THE USE OF CT'S AND OR VT'S IN ACCORDANCE WITH SECTION 1800, CPS ENERGY WILL FURNISH THE TRANSFORMER MOUNTING BRACKETS FOR INSTALLATION BY CUSTOMER. CUSTOMER INSTALLS THE TRANSFORMER MOUNTING BRACKETS AS A TEMPLATE FOR CPS ENERGY. CPS ENERGY WILL LATER INSTALL THE CT'S AND OR VT'S AND CONNECT THEM TO THE METER WHEN THE SERVICE-DROP IS INSTALLED.
2. THE ABOVE DRAWING IS FOR A TYPICAL CT /VT, SERVICE-DROP INSTALLATION WHERE CPS ENERGY INSTALLS OPEN SERVICE-DROP CONDUCTORS OR CUSTOMER INSTALLS PARALLEL SERVICE-ENTRANCE CONDUCTORS, WHERE A CABLED SET OF SERVICE-DROP CONDUCTORS IS INSTALLED, OTHER CONFIGURATIONS FOR THE ANCHORAGE AND TRANSFORMER-MOUNTING BRACKETS WILL BE REQUIRED, (REFER TO FIGURE 500.6).
3. CUSTOMER FURNISHES AND INSTALLS THE 1 1/4-INCH METERING CONDUIT AND SERVICE HEAD. CUSTOMER IS ADVISED TO CLOSELY COORDINATE THIS TYPE OF INSTALLATION WITH CPS ENERGY'S CUSTOMER SERVICE REPRESENTATIVE.

FIGURE 500.8
OVERHEAD CONDUCTOR CLEARANCES (SWIMMING POOL)

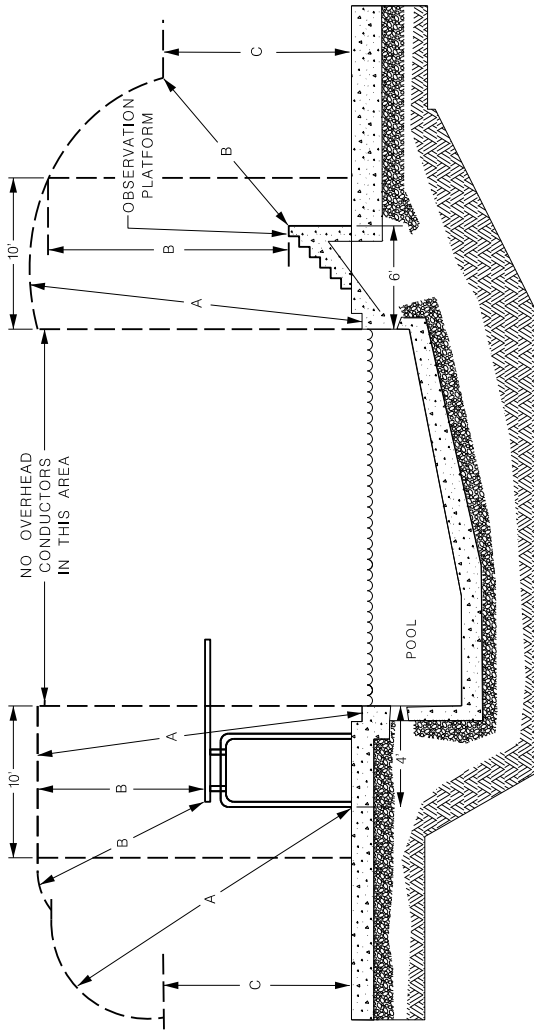

	CABLED SERVICE, 0 TO 750 VOLTS SUPPORTED BY GROUNDING BARE MESSENGER	ALL OTHER CONDUCTORS WITH VOLTAGE TO GROUND 750 VOLTS TO 22 KV (TO INCLUDE SYSTEM NEUTRAL)
A. CLEARANCE IN ANY DIRECTION FROM THE WATER LEVEL OF POOL, BASE OF DIVING PLATFORM, OR ANCHORED RAFT	22.5 FEET	25 FEET
B. CLEARANCE IN ANY DIRECTION TO THE DIVING PLATFORM OR TOWER	14.5 FEET	17 FEET
C. VERTICAL CLEARANCES OVER ADJACENT LAND	CLEARANCES AS REQUIRED BY FIGURE 500.1 AND NESC RULE 232	CLEARANCES AS REQUIRED BY FIGURE 500.1 AND NESC RULE 232

EXCEPTION 1: THIS RULE DOES NOT APPLY TO A POOL FULLY ENCLOSED BY A SOLID OR SCREENED PERMANENT STRUCTURE.

EXCEPTION 2: THIS RULE DOES NOT APPLY TO EFFECTIVELY GROUND SURGE-PROTECTION WIRES, NEUTRAL CONDUCTORS MEETING RULE 230E1, GUYS AND MESSENGERS, SUPPLY CABLES MEETING RULE 230C1, AND SUPPLY CABLES OF 0 TO 750 V MEETING RULES 230C2 OR 230C3 WHEN THESE FACILITIES ARE 10-FEET OR MORE HORIZONTALLY FROM THE EDGE OF THE POOL, DIVING PLATFORM, OR DIVING TOWER.

A CPS ENERGY CUSTOMER SERVICE REPRESENTATIVE WILL BE MADE AVAILABLE TO ASSIST CUSTOMERS WITH DETAILED INFORMATION CONCERNING SWIMMING POOL INSTALLATION.

FIGURE 500.9
OVERHEAD RESIDENTIAL SERVICE, TWO OR MORE METERS FROM GUTTER

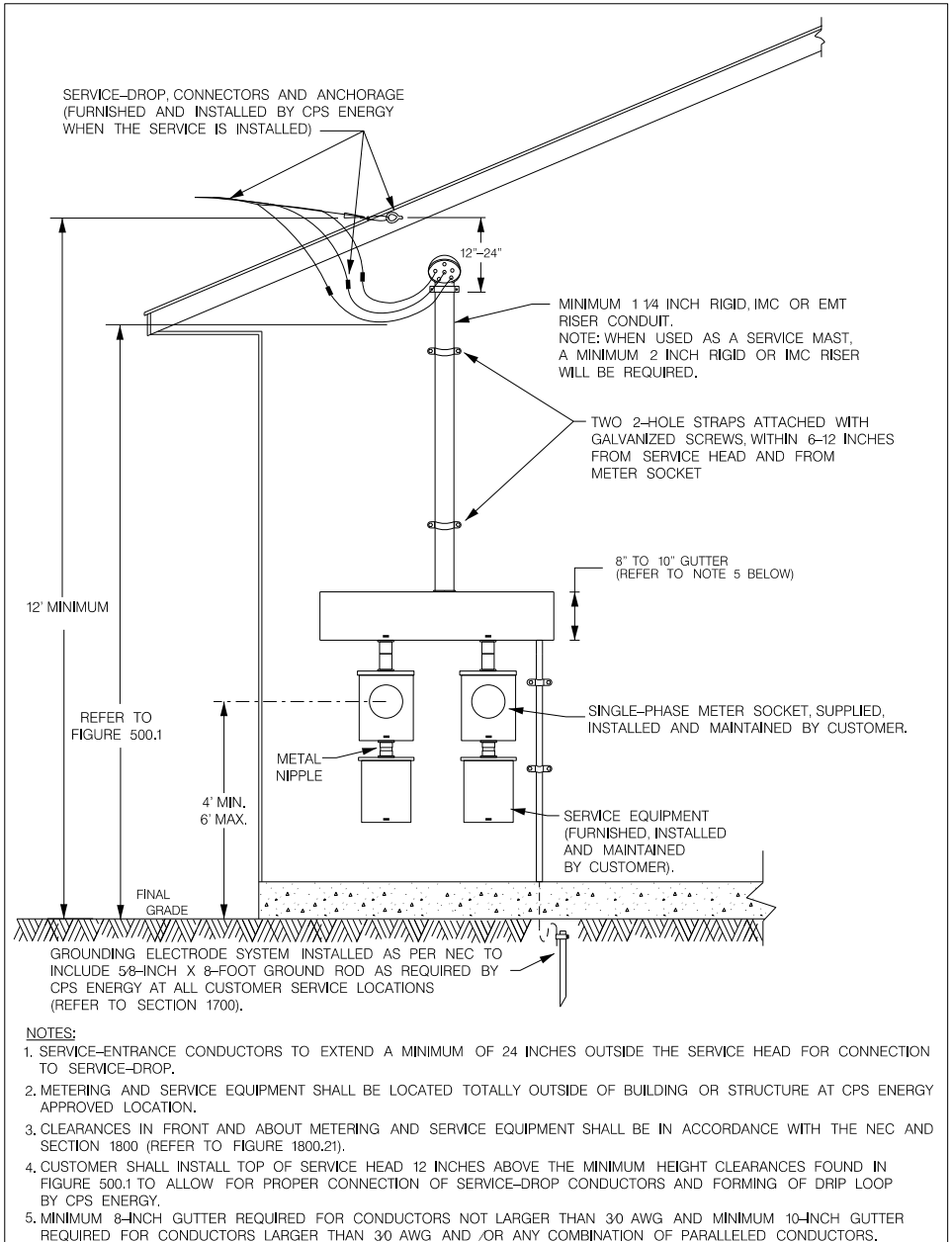
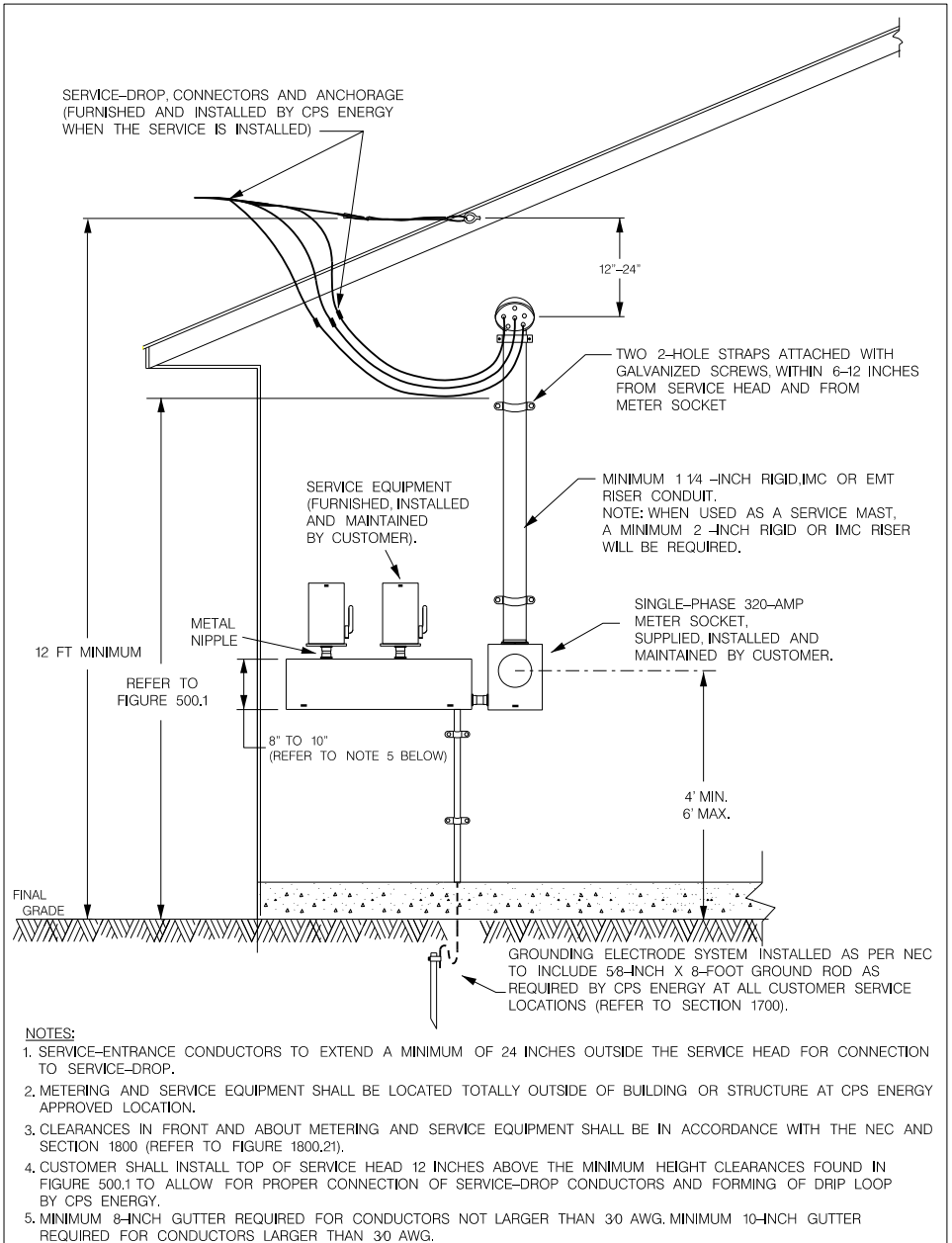

FIGURE 500.10
 OVERHEAD RESIDENTIAL SERVICE, 320-AMP SINGLE-PHASE METER SUPPLYING GUTTER



SECTION 600

OVERHEAD TO UNDERGROUND SECONDARY SERVICE

OVERHEAD TO UNDERGROUND SECONDARY SERVICE



601 General:

This type of service can be used for both commercial and residential occupancies where an overhead service drop from a distribution pole is either not an option or not desired. A service lateral installed underground in conduit(s) from a CPS Energy transformer pole (riser pole) to meter loop on Customer's building or structure supplies service. Customer shall contact the CPS Energy Customer Service Representative for proper coordination.

Note: *In some cases, CPS Energy may deem it necessary to furnish and install secondary clearance poles downstream from transformer pole to be used as the riser pole.*

601.1 Easements for CPS Energy Facilities:

Easements may be required for CPS Energy facilities including primary distribution, transformer poles, and secondary clearance poles that are installed on or overhang private property. CPS Energy facilities may also be installed in alleys, streets or other public right-of-way.

(A) Restricted Use of Easements:

Customer shall not permit any structure(s) such as: storage buildings, swimming pools, spas, decks, patios, carports, garages, concrete walks, and drives or equipment to be temporarily or permanently positioned within easements.

Note: *CPS Energy will not permit temporary or permanent structures to be placed in a manner that will obstruct CPS Energy access for maintenance or repair of CPS Energy Facilities, even if they are not located in an easement.*

(B) Call Before Digging:

Texas law requires anyone who plans to excavate to notify 1(800)Dig Tess or 811 "One Call" for location of underground facilities at least two working days in advance so that the utilities' lines can be located and marked for safety (Refer to "Helpful Numbers" listed on the inside front cover page).

601.2 CPS Energy Facilities and Maintenance:

CPS Energy will own, operate, and maintain transformer poles, secondary clearance poles, primary wires/cables, secondary cables, conduits, metering enclosures, service laterals, and kWh meters. CPS Energy may provide maintenance as required to meter sockets.

602 Standard Installation (Refer to Figures 600.1 thru 600.3):

A standard overhead to underground system installation will typically consist of the basic equipment and steps listed in (1) through (4) below. Customer shall review the referenced articles for more specific information and requirements.

- (1) Primary voltage wires/cables, transformer pole, transformers, and where required, secondary clearance poles furnished and installed by CPS Energy.
- (2) Standard length of intermediate metal conduit (IMC) riser(s) furnished and installed by Customer supported with standoff brackets furnished and installed by CPS Energy on riser pole (Refer to Article 603).

- (3) Service laterals furnished and installed by CPS Energy in conduits furnished and installed by Customer. The service lateral typically is installed from the pole mounted transformer's terminals directly to the metering equipment located on the building or structure (Refer to Articles 604 and 605).
- (4) CPS Energy furnished metering equipment installed by Customer at locations approved by CPS Energy (Refer to Article 607).

603 CPS Energy Riser Pole:

CPS Energy will furnish and install riser pole and necessary conduit brackets before Customer installs the underground service lateral conduit(s) including a standard length of IMC conduit(s) up the riser pole. Customer shall align service lateral conduits and IMC riser with CPS Energy conduit brackets and connect using an approved method. Customer shall not alter CPS Energy conduit bracket position on the pole (Refer to Figure 600.3).

604 Service Lateral Conduits:

Service laterals shall be totally enclosed in conduits. The conduits shall be continuous except for watertight couplings. All conduits, elbows, and couplings shall be furnished and installed by Customer from riser pole to meter loop to include a standard length of IMC riser(s) at pole.

604.1 Approved Types of Conduits:

Service lateral conduits installed below ground shall be schedule 40 PVC with all elbows required to be RMC/IMC and adequately protected against corrosion.

Service lateral conduits installed above ground shall be IMC at riser pole and either RMC or IMC at meter loop.

Exception 1: Residential installations and garden style apartment complexes will be permitted to use schedule 80 PVC elbows and schedule 80 PVC minimum above ground (Refer to Definition of "Garden Style Apartment Complex").

Exception 2: Where there is a possibility of physical damage to buried service lateral conduits, schedule 80 PVC shall be installed for the entire underground conduit system.

604.2 Size of Conduits:

The size of service lateral conduits shall be as specified for the job by CPS Energy's Customer Service Representative and will be based on length, number of bends, and the type and number of conductors that CPS Energy will install. Typically, all conduits from riser poles shall either be 3 inches or 4 inches. All elbows utilized shall have a minimum radius of 36 inches at the riser pole and 36 inches at the meter loop.

Exception: Elbows utilized on residential installations shall have a minimum radius of 24 inches at the meter loop.

604.3 Conduit Depth:

Trench shall be of adequate depth and width to accommodate minimum conduit dimensions and have a minimum of 24 inches of cover on top of conduits in private properties and a minimum of 36 inches of cover in public right-of-way.

Note 1: Customer may be required to taper the trench at elbow end to 36 inches to compensate for the 36-inch elbows.

Note 2: Where 4-inch conduit is specified by CPS Energy, or where elbows have a radius larger than 36 inches, the minimum cover may be increased to 36 inches.

604.4 Number of Conduits:

A maximum of two service lateral conduits will be permitted and each conduit shall contain one each of the ungrounded (phase) and neutral conductors. Each conduit shall have the same physical characteristics.

604.5 Conduits Reamed:

Before any conduit is installed, the conduit ends shall be reamed. The entire conduit system shall be left clean and clear for installation of CPS Energy service lateral.

604.6 Service Conduit Routing:

Underground service lateral conduits shall be totally outside the building and located to provide the shortest practical distance between the CPS Energy riser pole and the meter loop.

604.7 Conduit Connection to Metering/Service Equipment:

Customer shall terminate and secure service lateral conduits to metering or service equipment located on the outside of Customer's building or structure. CPS Energy will approve this location for termination of the service lateral conductors and as the point of delivery (POD). Customer shall furnish and install the necessary cable connectors for termination to equipment (Refer to Article 605).

604.8 Not Permitted Under Buildings or Structures:

Underground service lateral conduits shall not be installed under buildings or structures. Customer shall install metering equipment and provide service disconnecting means and overcurrent protection before service-entrance conductors enter into buildings or structures (Refer to Section 400).

Exception 1: CPS Energy will review special circumstances where disconnecting means located outside may create an undue hardship for the Customer. Where CPS Energy approves the disconnecting means to be located inside due to such hardship, the metering equipment shall be located outside and the POD will be at the load-side of the metering equipment. Customer shall be responsible for furnishing, installing, and maintaining that portion of the service conduit(s) from the load-side of the metering equipment to the Customer's disconnecting means inside the building.

Exception 2: CPS Energy will review proposed designs where special circumstances may require the use of meter rooms within the building for location of multiple metering equipment. Where CPS Energy approves such designs, Customer shall be responsible for that portion of the service conduit(s) under the building or structure. Service conduits under a building or structure shall be installed as required to be considered outside of the building and shall terminate within 4 feet upon entering CPS Energy approved electric meter rooms. CPS Energy may require Customer to install spare conduits and to locate meter rooms on exterior walls as close as possible to

transformer poles (Refer to Definition of "Conductors Considered Outside of Building").

604.9 Under Drivable Surfaces:

Where service lateral conduits are to be located underneath a drivable surface, they shall be installed on spacers every 4 feet and be staked down at every 5 to 7 feet. In addition, the conduit installation shall meet the provisions outlined in (1) through (3) below:

- (1) Conduits where crossing under drivable surfaces shall be installed with a minimum of 24 inches of cover on top of conduits in private properties and a minimum of 36 inches of cover in public right-of-way unless otherwise specified by CPS Energy.
- (2) Other than residential driveways, trench and conduits shall be backfilled with flowable fill up to no less than 6 inches of pavement surface.
- (3) An inspection by a CPS Energy inspector of trenching and conduits will be required before backfilling (Refer to Article 604.12 and 604.13).

Note 1: *CPS Energy reserves the right to require removal of backfill and/or flowable fill where Customer backfills without first obtaining the required CPS Energy inspections.*

Note 2: *CPS Energy shall not be responsible for any damage to driveways or other drivable areas as a result of trenching.*

604.10 Conduit Sleeves:

Where Customer needs to install sidewalks, driveways or streets prior to the installation of underground service lateral conduits, Customer shall first obtain approval from CPS Energy's Customer Service Representative and then shall install conduit sleeves in accordance with (1) through (6) below:

- (1) Sleeves shall consist of a 6-inch schedule 40 or schedule 80 PVC conduit installed on spacers every 4 feet and staked down at every 5 to 7 feet. One sleeve is required for each underground service lateral conduit specified by CPS Energy to be installed within trench.
- (2) Sleeves shall have a minimum of 24 inches of cover on top of conduits in private properties and a minimum of 36 inches of cover in public right-of-way unless otherwise specified by CPS Energy.
- (3) Sleeves shall extend a minimum of 12 inches on each side of sidewalks, driveways and parking lots, and a minimum of 24 inches if located under streets. Conduit sleeves shall be capped at each end with an approved PVC cap. Customer shall mark on the surface, the beginning and end of each sleeve location, with a stake, hub, pipe, or some other visible marker approved by CPS Energy.
- (4) Other utilities shall not be allowed in sleeves installed for CPS Energy.
- (5) Trench for conduit sleeves shall be backfilled with approved materials in accordance with CPS Energy specifications.

Note: For other than residential driveways, trench and conduit sleeves shall be backfilled with flowable fill up to no less than 6 inches of pavement surface.

- (6) All sleeve routes and locations require CPS Energy approval and inspections prior to backfilling (Refer to Article 604.12 and 604.13).

Exception: Sleeves installed under residential driveways.

604.11 Clearance from Other Buried Utilities:

Clearance of service conduits from other buried utilities shall be 12 inches minimum for commercial service installations and for residential service installations random lay will be permissible. Depth of trench shall be coordinated with CPS Energy's Customer Service Representative to assure minimum clearances are maintained.

604.12 CPS Energy Inspections:

The service trench and conduit installation must be inspected by a CPS Energy inspector prior to backfilling the trench. If flowable fill encasement is required, an inspection must be made before pouring the flowable fill and after flowable fill has been poured. City inspectors or other AHJ inspectors do not perform these inspections. To schedule an inspection, Customer may contact the CPS Energy Customer Service Representative or refer to "Helpful Numbers" listed on the inside front cover page.

Note 1: Where communication utilities are approved to share trench with CPS Energy, a second inspection may be required where flowable fill is interrupted to install such utilities.

Note 2: CPS Energy shall not accept nor take ownership of conduits until after service lateral has been installed.

604.13 Backfill Provisions:

Materials used to backfill a trench shall be clean and free of sharp objects. Customer shall be responsible for backfilling service lateral conduits in accordance with CPS Energy specifications.

605 Service Lateral Conductors:

Service lateral conductors will be furnished and installed by CPS Energy. Service lateral conductors shall be continuous from the secondary spades of CPS Energy transformers to the metering or service equipment located at Customer meter loop. CPS Energy will approve this location for termination of service lateral conductors and as the POD.

605.1 Load Limitations:

Overhead to underground service will be limited to demand loads not exceeding 300 kVA for three-phase and 100 kVA for single-phase, 120/240-volt service.

605.2 Conductor Sizes:

CPS Energy will furnish and install a maximum of two 500 KCM copper, 90°C conductors per phase for this type of service.

605.3 Termination of Service Lateral Conductors (Point of Delivery):

CPS Energy shall terminate the service lateral conductors onto properly sized and listed terminals or devices furnished by Customer at one of the metering or service equipment locations outlined in (A) through (E) below:

(A) Modular Metering Equipment:

At the line-side of Customer furnished and installed modular metering equipment. Modular metering equipment shall be approved by CPS Energy as meeting CPS Energy standards and specifications. Customer shall coordinate the review and approval of modular metering equipment with the CPS Energy Customer Service Representative (Refer to Section 1800).

(B) Independent Main Disconnecting Device:

At the line-side of Customer furnished and installed main service disconnecting means (device) where installed ahead of an auxiliary gutter supplying metering equipment. Customer's main disconnecting means shall be provided with lockable and sealable means.

(C) Step-Bus Auxiliary Gutter:

Directly to bus within Customer furnished and installed step-bus auxiliary gutter meeting CPS Energy standards and specifications. Step-bus auxiliary gutter shall be provided with lockable and sealable means for use by CPS Energy where installed ahead of CPS Energy metering equipment.

Note: Step-bus auxiliary gutter is required any time service lateral conductors, or any one set of service-entrance conductors exceed single 500 KCM conductors or parallel 350 KCM conductors.

(D) Junction/Pull Box:

Directly to Customer's service-entrance conductors within junction box which is required by CPS Energy ahead of an auxiliary wire gutter. The junction box shall be sized and installed in accordance with Figure 800.2 and shall be provided with lockable and sealable means for use by CPS Energy due to un-metered conductors. Junction box and auxiliary gutter shall be furnished and installed by Customer.

Exception: Junction box is not required ahead of auxiliary wire gutters serving duplex installations where gutters have minimum dimensions of 16 inches (H) x 8 inches (D) x appropriate length required to extend under each meter socket.

(E) Self-Contained Meter Socket or Instrument Transformer Enclosure:

For one meter installations, at the load-side of an individual self-contained meter socket or at the load-side of current transformers where required (Refer to Section 1800).

Note: CPS Energy shall first approve one of the above locations and shall designate location as the POD.

606 Service-Entrance Conductors:

Customer is responsible for furnishing and installing all service-entrance conductors on the load-side of the POD as outlined in Article 605.3.

606.1 Size:

Service-entrance conductors shall have sufficient ampacity to carry the load as determined by the NEC and other applicable codes, and in no case, be smaller than No. 8 AWG copper or No. 6 AWG aluminum. Service-entrance conductor sizes shall not exceed those specified by CPS Energy for meter sockets or other CPS Energy metering equipment (Refer to Section 1800).

606.2 Identification:

Customer shall clearly and permanently identify the grounded (neutral) conductor(s) of the service-entrance conductors before CPS Energy connects the service lateral (Refer to Section 400).

607 Metering:

All metering equipment shall be installed on the exterior of building or structure at a location approved by the CPS Energy Customer Service Representative and in accordance with Section 1800. Customer shall provide CPS Energy an approved space on the building wall or structure for metering equipment (Refer to Figures 600.1 and 600.2).

Note: *Where space is not available on building wall, Customer shall provide a suitable metering equipment rack separate from building (Refer to Definition of "Metering Equipment Rack" and Figure 1800.20).*

Exception: *CPS Energy will review proposed designs where special circumstances may require the use of meter rooms within the building for location of multiple metering equipment. Where CPS Energy approves such designs, Customer shall be responsible for that portion of the service conduit(s) under the building or structure. Service conduits under the building or structure shall be installed as required to be considered outside of the building and shall terminate within 4 feet upon entering CPS Energy approved electric meter rooms. CPS Energy may require Customer to install spare conduits and to locate meter rooms on exterior walls as close as possible to the transformer poles (Refer to Definition of "Conductors Considered Outside of Building").*

FIGURE 600.1
 UNDERGROUND SERVICE (SINGLE-METER) FROM OVERHEAD FACILITIES

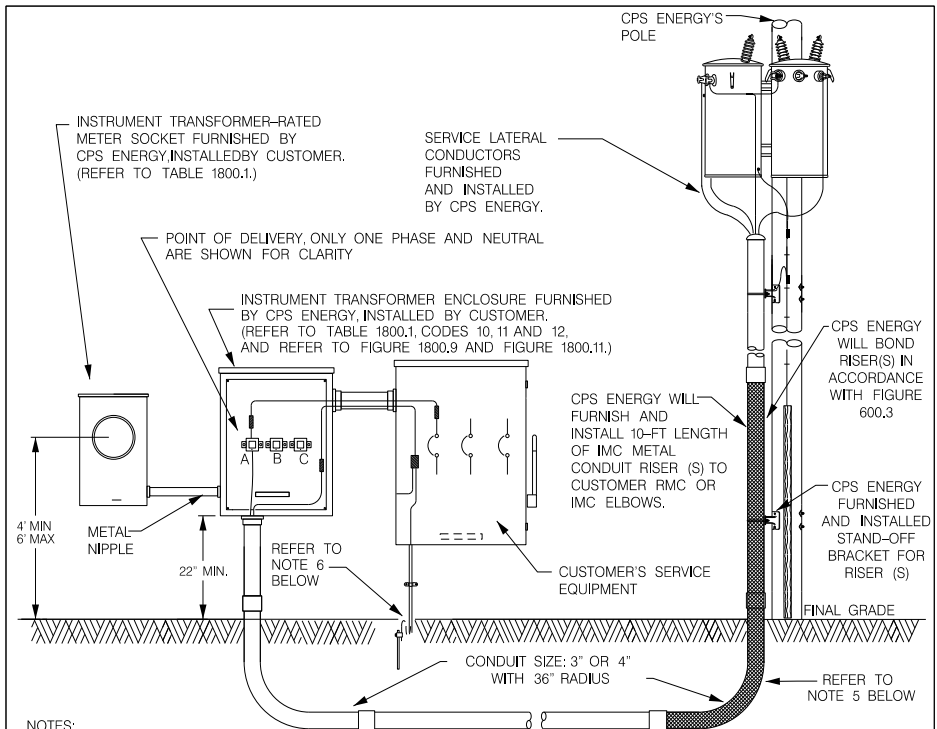

NOTES:

1. AN UNDERGROUND SERVICE LATERAL FROM A CPS ENERGY OVERHEAD SECONDARY LINE OR TRANSFORMER BANK MAY BE INSTALLED AS SHOWN ABOVE. CUSTOMER MUST CLOSELY COORDINATE THIS TYPE OF INSTALLATION WITH CPS ENERGY CUSTOMER SERVICE REPRESENTATIVE. THIS TYPE OF SERVICE IS LIMITED TO THREE-PHASE DEMAND LOADS WHICH CAN BE SERVED WITH TWO 500 KCM COPPER CONDUCTORS PER PHASE, OR EQUIVALENT IN SMALLER CONDUCTORS. CONDUCTOR SIZES LARGER THAN 500 KCM WILL NOT BE INSTALLED. VOLTAGE DROP IN THE SERVICE LATERAL CONDUCTORS MAY LIMIT SERVICE LATERAL LENGTH.
2. THE CONDUIT FROM THE CT ENCLOSURE THROUGH THE ELBOWS ON THE POLE SHALL BE FURNISHED AND INSTALLED BY CUSTOMER, ALL IN ACCORDANCE WITH CPS ENERGY SPECIFICATIONS. THE ELBOWS ON THE POLE SHALL BE RMC OR IMC. THE REMAINING CONDUIT MAY BE SCHEDULE 40, BUT WHERE THERE IS A POSSIBILITY OF PHYSICAL DAMAGE, THE CONDUIT SHALL BE SCHEDULE 80 PVC. ALL CONDUIT AND ELBOWS AT THE BUILDING OR STRUCTURE SHALL BE SCHEDULE 80 OR BETTER AND BE FURNISHED AND INSTALLED BY CUSTOMER. NOTE: RMC OR IMC ELBOWS WILL NOT BE REQUIRED FOR RESIDENTIAL INSTALLATIONS AND GARDEN STYLE APARTMENT COMPLEXES SUPPLIED FROM OVERHEAD TO UNDERGROUND SERVICE.
3. CPS ENERGY MAY INSTALL CONDUIT GUIDES AT RISER POLE FOR CUSTOMER FOR THE ALIGNMENT OF SERVICE LATERAL CONDUITS FURNISHED AND INSTALLED BY CUSTOMER. CPS ENERGY WILL THEN FURNISH AND INSTALL A STANDARD LENGTH OF IMC RISER(S) AND THE REMAINDER OF LENGTH OF RISER(S) IN SCHEDULE 40 PVC. NOTE: CPS ENERGY WILL NOT INSTALL IMC RISERS FOR RESIDENTIAL INSTALLATIONS AND GARDEN STYLE APARTMENT COMPLEXES SUPPLIED FROM OVERHEAD TO UNDERGROUND SERVICE.
4. CONDUITS WHERE CROSSING UNDER DRIVABLE SURFACES SHALL BE INSTALLED WITH A MINIMUM COVER OF 24 INCHES IN PRIVATE PROPERTY AND A MINIMUM OF 36 INCHES IN PUBLIC RIGHT-OF-WAYS UNLESS OTHERWISE SPECIFIED BY CPS ENERGY. TRENCH AND CONDUITS SHALL BE BACKFILLED WITH FLOWABLE FILL UP TO NO LESS THAN 6 INCHES OF PAVEMENT SURFACE. AN INSPECTION BY CPS ENERGY OF ALL TRENCHING AND CONDUITS WILL BE REQUIRED BEFORE BACKFILLING.
5. RMC OR IMC ELBOW(S) FURNISHED AND INSTALLED BY CUSTOMER TO ALIGN WITH RISER(S) OR CONDUIT GUIDES FURNISHED AND INSTALLED BY CPS ENERGY.
6. GROUNDING ELECTRODE SYSTEM INSTALLED AS PER NEC TO INCLUDE 5/8-INCH X 8-FT GROUND ROD AS REQUIRED BY CPS ENERGY AT ALL CUSTOMER SERVICE LOCATIONS. (REFER TO SECTION 1700).

FIGURE 600.2
UNDERGROUND SERVICE (MULTI-METER) FROM OVERHEAD FACILITIES

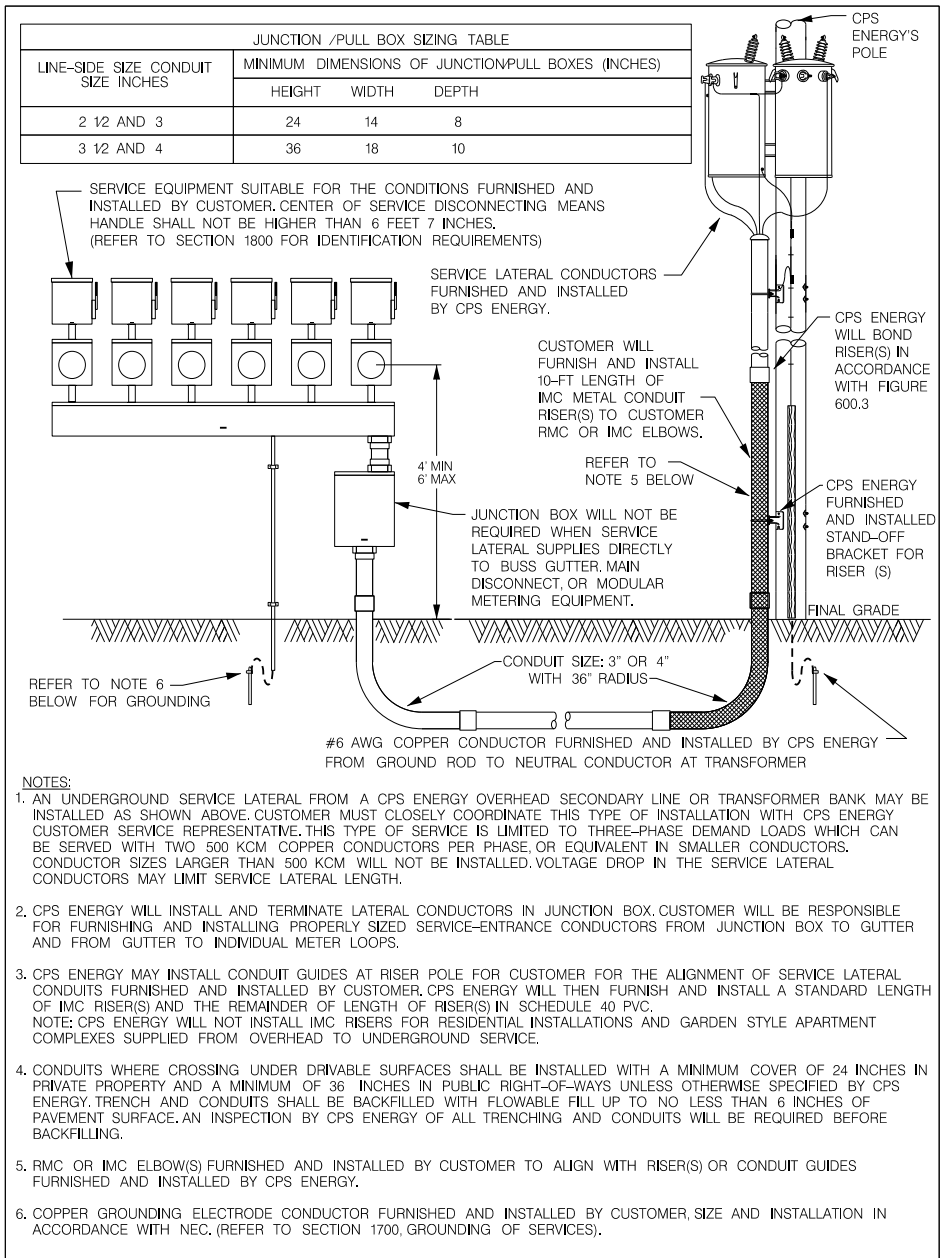
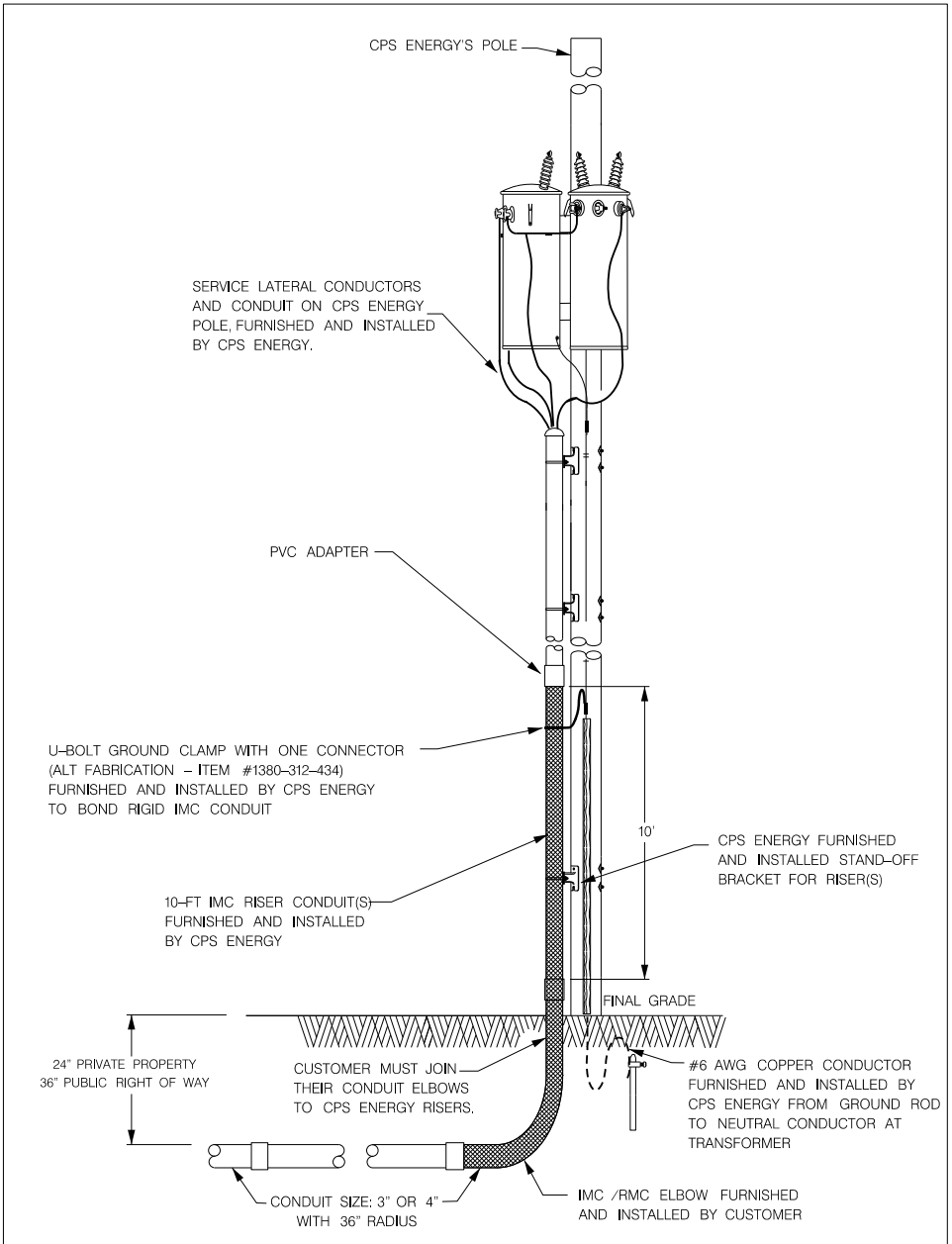

FIGURE 600.3
RIGID CONDUIT BONDING
UNDERGROUND SERVICE FROM OVERHEAD FACILITIES



SECTION 700

UNDERGROUND RESIDENTIAL DISTRIBUTION (URD) SERVICE

**UNDERGROUND RESIDENTIAL
DISTRIBUTION (URD) SERVICE**



701 General:

This type of service is designed for residential subdivisions where all utilities are installed underground. An Underground Residential Distribution (URD) service lateral installed underground in conduit from a CPS Energy transformer or secondary enclosure to meter loop on Customer building or structure supplies service. Customer shall request this type of service either through the CPS Energy Web Portal or by calling (210) 353-4050.

701.1 Final Grades Provided by Customer:

Customer is responsible for providing finished grades before CPS Energy installs transformers and trenches for primary voltage ducts and secondary laterals. In cases where the final grades are changed after CPS Energy has begun the installation of the infrastructure, the re-design and construction charges associated with the changes will be the Customer's responsibility. Customer shall identify all property lines as required by CPS Energy.

701.2 Easements for Underground Facilities:

CPS Energy facilities including primary distribution, transformers and pads, secondary laterals, and secondary enclosures will be installed in easements as determined by the CPS Energy Customer Service Representative. CPS Energy facilities may also be installed in alleys, streets or other public right-of-way.

Note: CPS Energy will not permit temporary or permanent structures to be placed in a manner that will obstruct CPS Energy access for maintenance or repair of CPS Energy Facilities, even if they are not located in an easement.

(A) Restricted Use of Easements:

Customer shall not permit any structure(s) such as: storage buildings, swimming pools, spas, decks, patios, car ports, garages, concrete walks, and drives or equipment to be temporarily or permanently positioned over electric and/or gas lines or in their easements.

Note: While easements are not required for routing of URD service laterals and conduits, CPS Energy will not permit temporary or permanent structures to be placed in a manner that will obstruct CPS Energy access for maintenance or repair to service laterals and conduits.

(B) Call Before Digging:

Texas law requires anyone, including homeowners, who plan to excavate to notify 1(800)Dig TESS or 811 "One Call" for location of underground facilities at least two working days in advance so that the utilities' lines can be located and marked for safety ("Helpful Numbers" listed on the inside front cover page).

701.3 CPS Energy Facilities and Maintenance:

CPS Energy will own, operate, and maintain transformer installations, primary and secondary cables, conduits, secondary enclosures, service laterals, and kWh meters. CPS Energy may perform maintenance as required to meter sockets.

701.4 Commercial Service from URD Area:

Services to commercial businesses are generally not allowed from a URD system. Where there are no other distribution facilities available, CPS Energy may

allow a commercial service from the URD distribution system upon approval from CPS Energy's Engineering Department.

702 Standard Installation (Refer to Figure 700.1):

A standard URD system installation will typically consist of the basic equipment and steps listed in (1) through (4) below. Customer shall review the referenced articles for more specific information and requirements.

- (1) Primary voltage cables in conduit furnished and installed by CPS Energy.

***Exception:** With prior CPS Energy approval, Customer may elect to use contractors to trench and install conduits. The contractor shall coordinate with the CPS Energy Customer Service Representative to have all necessary inspections before covering or pouring (Refer to Helpful Numbers on back of front cover page).*

- (2) Padmount single-phase transformers and associated pads; transformers and pads to be furnished and installed by CPS Energy. Only single-phase, three-wire, 120/240-volt service will be supplied for URD installations (Refer to Article 703).

***Exception:** With prior CPS Energy approval, Customer may elect to construct transformer pads. Customer shall coordinate with the CPS Energy Customer Service Representative to have all necessary inspections before covering or pouring (Refer to "Helpful Numbers" listed on the inside front cover page).*

- (3) Service laterals in conduits furnished and installed by CPS Energy. The service lateral typically is installed from padmount transformer's terminals or from secondary enclosure directly to the meter socket on the building or structure (Refer to Articles 704 and 705).

***Exception:** With prior CPS Energy approval, Customer may elect to use contractors to install trenching and conduits. The contractor shall coordinate with the CPS Energy Customer Service Representative to have all necessary inspections before covering or pouring (Refer to "Helpful Numbers" listed on the inside front cover page).*

***Note:** Where overhead lines are installed along a property that is located in a URD system, service laterals may be supplied from distribution poles.*

- (4) CPS Energy approved single-phase, self-contained, residential meter sockets to be furnished and installed by Customer at locations approved by CPS Energy (Refer to Article 707).

703 Transformers:

CPS Energy will determine the number and location of padmount transformers that will be installed in a URD system. Customer shall furnish space meeting all clearance and easement requirements for each transformer and shall allow it to be readily accessible.

703.1 Transformer Pads:

Pads for single-phase transformers up to 167 kVA shall be precast concrete and shall be furnished by CPS Energy. In special cases approved by CPS

Energy where larger transformers are needed, transformer slabs will need to be constructed in accordance with CPS Energy specifications. Customer shall coordinate with the CPS Energy Customer Service Representative for more information.

- (1) No transformers, cable or other CPS Energy facilities will be installed in rear or side lot locations unless the grade of the property is 10 percent or less and a drivable surface is installed to access transformers. All transformer pad sites are to be leveled by the Developer.
- (2) No transformers, cable or other CPS Energy facilities will be installed in areas that are prone to flooding. Any conduits installed across an earthen drain must be encased in 1500 PSI concrete.

703.2 Secondary Laterals and Enclosures:

Depending on the load and locations to be served, CPS Energy may furnish and install secondary laterals and secondary enclosures between the secondary side of the transformer and the meter socket. Conduits and trenching will be in accordance with the requirements outlined for service lateral conduits and conductors (Refer to Articles 704 and 705).

704 Service Lateral Conduits:

Service laterals shall be totally enclosed in conduits. All conduits, elbows, and couplings shall be furnished and installed by CPS Energy from transformer or secondary enclosure to meter loop. The conduit system shall be continuous except for watertight couplings (Refer to Figure 700.1).

704.1 Approved Types of Conduits:

Standard service lateral conduits shall be schedule 40 PVC with all elbows required to be schedule 80 PVC. Where there is possibility of physical damage to service lateral conduits, schedule 80 PVC shall be installed for the entire conduit system.

704.2 Size of Conduits:

The size of service lateral conduits to residential buildings shall be as specified for the job by the CPS Energy Customer Service Representative and will be based on length, number of bends, and the type and number of conductors that CPS Energy will install. Typically, all conduits from padmount transformers to single position meter sockets shall be 3 inches unless otherwise specified by CPS Energy. Elbows at transformer end shall have a minimum radius of 30 inches and elbow at meter loop shall have a radius of 24 inches.

704.3 Conduit Depth:

Conduit trench shall be of adequate depth and width to accommodate minimum conduit dimensions with 24 inches of coverage on top of service lateral conduits.

Exception: *Where CPS Energy deems it necessary to route service lateral conduits and conductors in public right-of-way, the depth shall be a minimum of 36 inches to the top of conduits from final grade.*

704.4 Number of Conduits:

Only one conduit for service lateral conductors will be permitted and conduit shall contain the two ungrounded (phase) conductors and one neutral conductor.

Exception: Additional conduits that may need to be utilized for larger loads or duplexes will require prior approval from CPS Energy.

704.5 Service Conduit Routing:

Underground service lateral conduits shall be totally outside the building and located to provide the shortest practical distance between the CPS Energy transformer or secondary enclosure and the meter loop. Service lateral conduits will normally be located so they will contact the side of the building that the CPS Energy Customer Service Representative designates. Service laterals will normally run parallel to side property lines.

704.6 Conduit Connection to Meter Socket:

Service lateral conduits typically are connected directly to meter sockets. Customer shall provide a 3-inch PVC male adapter for termination to both 200 and 320-ampere meter sockets.

Exception 1: Where an auxiliary wire gutter or junction box is required by CPS Energy for multiple metering designs (Refer to Figure 800.2 and Section 1800).

Exception 2: Where instrument transformers are required by CPS Energy to supply larger residential loads (Refer to Section 1800).

704.7 Not Permitted Under Buildings or Structures:

Underground service lateral conduits shall not be installed under buildings or structures. Customer shall install metering equipment and provide service disconnecting means and overcurrent protection before service-entrance conductors enter into buildings or structures (Refer to Section 400).

704.8 Clearance from Swimming Pools:

Swimming or wading pools and any associated auxiliary equipment shall not be placed within a 5-foot radius of service laterals. Measurements from the pool will be taken from its inside edge. Swimming pool contractors are therefore advised to have all utilities located before excavation begins.

704.9 Clearance from Other Buried Utilities:

Clearance of service conduits from other buried utilities shall be 12 inches minimum for commercial service installations and for residential service installations random lay will be permissible. Depth of trench shall be coordinated with CPS Energy's Customer Service Representative to assure minimum clearances are maintained.

704.10 CPS Energy Inspections:

Where Customer elects to use their contractor to install the service lateral conduits, the service trench and conduit installation must be inspected by a CPS Energy inspector prior to backfilling the trench. City inspectors or other AHJ inspectors do not perform these inspections. To schedule an inspection, Customer may contact the CPS Energy Customer Service

Representative or refer to "Helpful Numbers" listed on the inside front cover page.

704.11 Backfill Provisions:

Materials used to backfill a trench shall be clean and free of sharp objects. Customer shall be responsible for backfilling service lateral conduit trench in accordance with CPS Energy specifications.

705 Service Lateral Conductors:

CPS Energy will furnish, install, and terminate service lateral conductors on the line-side of the meter socket. On duplex service installations, CPS Energy will terminate the service lateral conductors in Customer furnished auxiliary wire gutter or in a junction box, where required (Refer to Figure 800.2). The service lateral size will be based on calculated voltage drop at maximum demand, and maximum service lateral cable pulling tensions. The estimated demand loads and ampacities for meter sockets are outlined in Table 1800.2.

705.1 Maximum Length of Service Lateral:

The maximum service lateral distance shall be 250 feet from CPS Energy transformer or secondary enclosure to the meter loop on Customer's residence.

Exception 1: *Where the proposed service lateral is greater than 250 feet, and the transformer or secondary enclosure is located on an adjacent property, an additional transformer or secondary enclosure may be installed on the Customer's property, at Customer's expense, to minimize the service lateral length. This additional transformer or secondary enclosure shall be installed at the closest property corner to the existing transformer or secondary enclosure. Only one secondary enclosure will be permitted on a property.*

Exception 2: *For proposed service laterals where the distance from the transformer or secondary enclosure to the proposed meter location is greater than 250 feet, the meter and service equipment shall be located at the property line adjacent to the transformer or secondary enclosure. The point of delivery (POD) will be at the service equipment.*

706 Service-Entrance Conductors:

Service-entrance conductors typically are the conductors between the load-side of the meter socket to the line-side terminals of Customer's service equipment. Customer shall furnish and install service-entrance conductors including necessary terminals.

Exception 1: *Where an auxiliary wire gutter or junction box is required by CPS Energy for multiple metering designs, the service-entrance conductors shall be the conductors from the CPS Energy service lateral at that location to the line-side terminals of metering equipment (Refer to Figure 800.2 and Section 1800).*

Exception 2: *Where instrument transformers are required, the service-entrance conductors shall be the conductors connected to the service lateral on the load-side of the instrument transformers to the line-side terminals of Customer's service equipment (Refer to Section 1800).*

706.1 Size:

Service-entrance conductors shall have sufficient ampacity to carry the load as determined by the NEC and other applicable codes, but shall not be smaller than No. 8 AWG copper or No. 6 AWG aluminum. Conductor sizes and quantities shall not exceed those allowed for meter sockets or other CPS Energy metering equipment.

706.2 Identification:

Customer shall clearly and permanently identify the grounded (neutral) conductor(s) at all equipment locations and before CPS Energy connects the service lateral (Refer to Section 400).

707 Metering:

All metering equipment shall be installed on the exterior of buildings or structures in accordance with Section 1800. Customer shall provide CPS Energy an approved space on the building wall or structure for metering equipment. Customer shall furnish and install single-phase, self-contained meter sockets for single-phase 120/240-volt services provided on residences (Refer to Figure 1800.1).

Note: Service equipment for residential services shall be located at the same location as the metering equipment in accordance with Section 400.

FIGURE 700.1
 UNDERGROUND RESIDENTIAL DISTRIBUTION SERVICE, ONE-METER

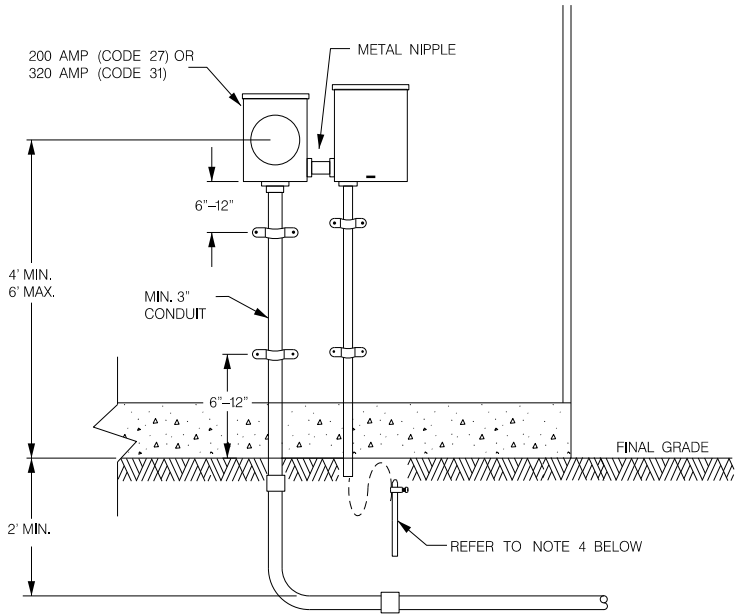

NOTES:

1. SINGLE-PHASE METER SOCKET FURNISHED AND INSTALLED BY CUSTOMER (REFER TO FIGURE 1800.1). CPS ENERGY FURNISHES AND TERMINATES THE SERVICE LATERAL TO METERING EQUIPMENT. CUSTOMER FURNISHES AND TERMINATES SERVICE-ENTRANCE CONDUCTORS FROM LOAD-SIDE OF METER EQUIPMENT.
2. SERVICE RACEWAY MUST BE MINIMUM 3 INCHES. IT MAY BE SCHEDULE 40 PVC CONDUIT, OR WHERE SUBJECT TO PHYSICAL DAMAGE, SCHEDULE 80 PVC CONDUIT SHALL BE USED. WHERE CPS ENERGY INSTALLS THE SERVICE LATERAL, CUSTOMER SHALL FURNISH THE RISER CONDUIT AND THE MALE ADAPTER FOR CONNECTION TO THE SOCKET.
3. TWO 2-HOLE PIPE STRAPS MUST BE INSTALLED BY CUSTOMER TO MOUNT THE SERVICE RACEWAY TO THE STRUCTURE. SPACING WILL BE BETWEEN 6 AND 12 INCHES FROM BOTH THE METER SOCKET AND THE GROUND LEVEL.
4. SERVICE EQUIPMENT SUITABLE FOR THE CONDITIONS FURNISHED AND INSTALLED BY CUSTOMER (REFER TO SECTION 400).
5. GROUNDING ELECTRODE SYSTEM INSTALLED AS PER NEC TO INCLUDE 5/8-IN X 8-FT GROUND ROD AS REQUIRED BY CPS ENERGY AT ALL CUSTOMER SERVICE LOCATIONS (REFER TO SECTION 1700).
6. CLEARANCES SHALL BE MAINTAINED FROM GAS METERS AND REGULATORS IN ACCORDANCE WITH SECTION 1800 AND FIGURE 1800.21.

FIGURE 700.2
UNDERGROUND RESIDENTIAL DISTRIBUTION SERVICE, TWO METERS

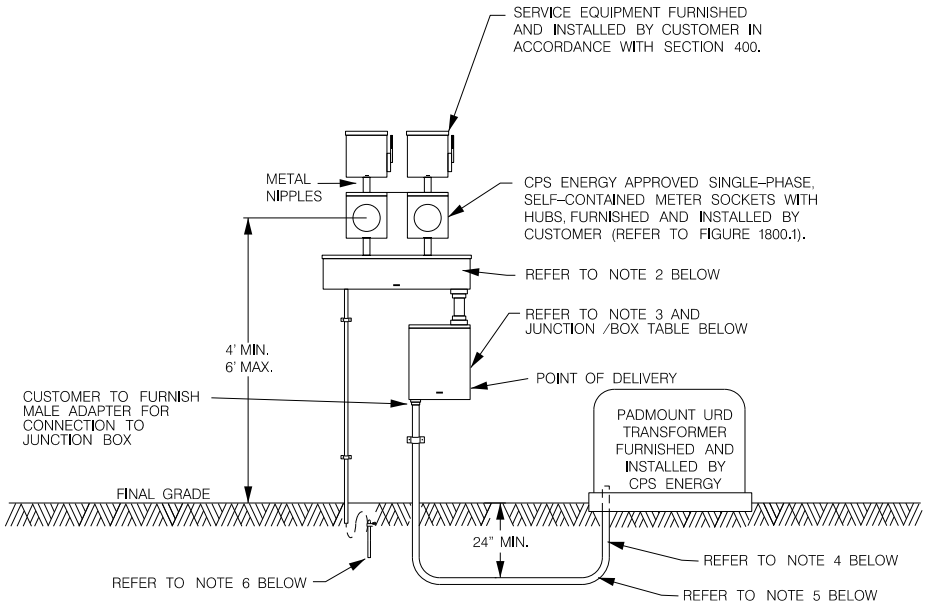

JUNCTION /PULL BOX SIZING TABLE			
LINE-SIDE SIZE CONDUIT SIZE INCHES	MINIMUM DIMENSIONS OF JUNCTION/PULL BOXES (INCHES)		
	HEIGHT	WIDTH	DEPTH
2 1/2 AND 3	24	14	8
3 1/2 AND 4	36	18	10

1. CPS ENERGY FURNISHES AND INSTALLS SERVICE LATERAL CONDUCTORS TO JUNCTION BOX OR GUTTER (REFER TO NOTE 3). CUSTOMER SHALL FURNISH AND INSTALL SERVICE-ENTRANCE CONDUCTORS BEYOND THAT POINT INCLUDING TO METERING EQUIPMENT.
 2. METAL AUXILIARY GUTTER WITH LOCKABLE MEANS SIZED PER NEC AND FURNISHED AND INSTALLED BY CUSTOMER. (CUSTOMER FURNISHES ALL WIRE IN GUTTER AND IN SOCKETS AND MAKES ALL CONNECTIONS)
 3. CUSTOMER-FURNISHED METAL JUNCTION /PULL BOX WITH LOCKABLE MEANS SIZED PER SIZING TABLE ABOVE FURNISHED AND INSTALLED BY CUSTOMER.
EXCEPTION: CUSTOMER-FURNISHED JUNCTION /PULL BOX SHALL NOT BE REQUIRED FOR DUPLEX INSTALLATIONS UTILIZING A METAL AUXILIARY GUTTER SIZED 16" (H) BY 8" (D) OR LARGER.
 4. SERVICE LATERAL CONDUCTORS MUST BE INSTALLED IN CONDUIT. CUSTOMER FURNISHES AND INSTALLS CONDUIT IN ACCORDANCE WITH CPS ENERGY SPECIFICATIONS.
 5. STANDARD CONDUIT IS 3- INCH PVC SCHEDULE 40 OR SCHEDULE 80 PVC RATED FOR ABOVE GROUND OR UNDERGROUND USE. MINIMUM ELBOWS RADIUS IS 24 INCHES.
- GROUNDING ELECTRODE SYSTEM INSTALLED AS PER NEC TO INCLUDE 5/8-INCH X 8-FOOT GROUND ROD AS REQUIRED
6. BY CPS ENERGY AT ALL CUSTOMER SERVICE LOCATIONS (REFER TO SECTION 1700).

SECTION 800

UNDERGROUND SERVICE IN APARTMENT COMPLEXES



**UNDERGROUND SERVICE
IN APARTMENT COMPLEXES**



801 General:

This type of service is designed for apartment complexes where all utilities are installed underground. A service lateral installed underground in conduit from a CPS Energy transformer or riser pole to meter loop on Customer's building or structure supplies service. Customer shall contact the CPS Energy Customer Service Representative for proper coordination.

801.1 Easements for Underground Facilities:

CPS Energy facilities including primary distribution, transformers, and service laterals will be installed in easements as determined by the CPS Energy Customer Service Representative.

(A) Restricted Use of Easements:

Customer shall not permit any structure(s) such as: storage buildings, swimming pools, spas, decks, patios, car ports, garages, concrete walks, and drives or equipment to be temporarily or permanently positioned within easements.

(B) Call Before Digging:

Texas law requires anyone who plans to excavate to notify 1(800)Dig Tess or 811 "One Call" for location of underground facilities at least two working days in advance so that the utilities' lines can be located and marked for safety (Refer to "Helpful Numbers" listed on the inside front cover page).

801.2 CPS Energy Facilities and Maintenance:

CPS Energy will own, operate, and maintain primary distribution, transformer installations, conduits, service laterals, and kWh meters. CPS Energy may perform maintenance as required to meter sockets.

801.3 Commercial Service from URD Area:

Services to commercial businesses are generally not allowed from a URD system. Where there are no other distribution facilities available, CPS Energy may allow a commercial service from the URD distribution system upon approval from CPS Energy's Engineering Department.

***Exception:** Commercial services for apartment complex leasing offices, clubhouses, etc. may be served from the same underground system as the apartment complex.*

802 Standard Installation: (Refer to Figure 800.1 and 800.2)

A standard underground system installation will typically consist of the basic equipment and steps listed in (1) through (4) below. Customer shall review the referenced articles for more specific information and requirements.

- (1) Primary voltage cables in conduit furnished and installed by CPS Energy.

***Exception:** With prior CPS Energy approval, Customer may elect to use contractors to install trenching and conduits. The contractor shall coordinate with the CPS Energy Customer Service Representative to have all necessary inspections before covering or pouring (Refer to "Helpful Numbers" listed on the inside front cover page).*

- (2) Padmount single-phase transformers and associated pads; transformers and pads to be furnished and installed by CPS Energy. Only single-phase, three-wire, 120/240-volt service will be supplied for apartment services (Refer to Article 803).

Exception: *With prior CPS Energy approval, Customer may elect to construct transformer pads. Customer shall coordinate with the CPS Energy Customer Service Representative to have all necessary inspections before covering or pouring (Refer to "Helpful Numbers" listed on the inside front cover page).*

- (3) Service laterals furnished and installed by CPS Energy in conduits and trench furnished and installed by Customer. The service lateral typically is installed from padmount transformer's terminals directly to metering equipment on the building or structure (Refer to Articles 804 and 805).

Note: *Where overhead lines are installed along a property that is located in a URD system, service laterals may be supplied from distribution poles.*

- (4) CPS Energy approved single-phase, self-contained meter sockets and/or modular metering equipment furnished and installed by Customer at CPS Energy approved locations (Refer to Article 807).

803 Transformers:

CPS Energy will determine the number and location of distribution transformers. Customer shall furnish space meeting all clearance and easement requirements for each transformer and shall allow it to be readily accessible by CPS Energy personnel.

803.1 Transformer Pads:

Pads for single-phase transformers up to 167 kVA shall be precast concrete and shall be furnished by CPS Energy. For 250 kVA transformers, Customer shall have the option of either having CPS Energy provide the precast concrete pad or they may elect to build a 6-foot x 6-foot concrete pad per CPS Energy specifications.

For transformers larger than 250 kVA, the Customer shall build a 6-foot x 6-foot concrete pad per CPS Energy specifications. All transformer pads must be installed such that the surface of the pad is 6 inches above finished grade. In addition, Customer shall furnish and install one 5/8-inch x 8-foot ground rod in the transformer pad. CPS Energy will install all necessary ground rod connectors.

- (1) All transformers, cable or other CPS Energy facilities will be installed in accessible locations and the grade of the property at any transformer location must be 10 percent or less. All transformer pad sites are to be leveled by the Developer.
- (2) No transformers, cable or other CPS Energy facilities will be installed in areas that are prone to flooding. Any conduits installed across an earthen drain must be encased in 1500 PSI concrete.
- (3) All transformer pads must have a minimum of 3 feet of clearance around the sides and rear of the pad and 6 feet of clearance in front. The

front side of a transformer pad is defined as the side where the transformer door/opening is located.

803.2 CPS Energy Job Sketch:

Customer shall stake transformer locations using the information in the CPS Energy provided Job Sketch.

804 Service Lateral Conduit:

Service laterals shall be totally enclosed in conduits. All service conduits, elbows, and couplings shall be furnished and installed by Customer from transformer or riser pole to meter loop. The conduit system shall be continuous except for watertight couplings (Refer to Figure 800.2).

804.1 Approved Types of Conduits:

Standard service lateral conduits shall be schedule 40 or schedule 80 PVC with all elbows required to be schedule 80 PVC. Where there is possibility of physical damage to the service lateral conduits, schedule 80 PVC shall be installed for the entire conduit system.

Note: Refer to Section 600 where the service lateral originates from a distribution riser pole.

804.2 Size of Conduits:

The size of service lateral conduits to apartment buildings shall be as specified for the job by the CPS Energy Customer Service Representative and will be based on length, number of bends, and the type and number of conductors that CPS Energy will install. Typically, all conduits from padmount transformers or riser poles to modular metering equipment or single position meter sockets shall be 3-inch unless otherwise specified by CPS Energy. All elbows utilized with 3-inch conduits shall have a minimum radius of 24 inches.

804.3 Depth of Conduits:

Conduit trench shall be of adequate depth and width to accommodate minimum conduit dimensions with 24 inches of coverage on top of conduits in private properties and a minimum of 36 inches of cover in public right-of-way unless otherwise specified by CPS Energy.

Note: Where 4-inch conduit is specified by CPS Energy, or when elbows have a radius larger than 24 inches, the minimum cover shall be increased to 36 inches.

804.4 Number of Conduits:

A maximum of two conduits for service conductors will be permitted and each conduit shall contain two ungrounded (phase) conductors and one neutral conductor. Each conduit shall have the same physical characteristics.

Exception: Additional conduits that may need to be utilized for larger loads will require prior approval from CPS Energy.

804.5 Service Lateral Conduit Routing:

Underground service lateral conduits shall be totally outside the building and located to provide the shortest practical distance between the CPS Energy transformer and the meter loop.

804.6 Conduit Connection to Metering/Service Equipment:

Customer shall terminate and secure service lateral conduits to metering or service equipment located on the outside of Customer's building or structure in accordance with design approved by CPS Energy. CPS Energy will approve this location for termination of the service lateral conductors and as the point of delivery (POD). Customer shall furnish and install the necessary connectors for termination to equipment.

804.7 Conductor and Conduit Schedule:

A conductor and conduit schedule shall be issued by the CPS Energy Customer Service Representative that will specify the quantity and size of conduits and conductors required for each service lateral run.

804.8 Conduit Locations at Transformer Pad:

Customer shall closely coordinate the location of the underground conduits within CPS Energy's transformer pad opening. To facilitate this, Customer shall review the Job Sketch provided by the CPS Energy Customer Service Representative that shows buildings, transformer locations, and conduit routes with required easements.

804.9 Conduits Reamed:

Before any conduit is installed, the conduit ends shall be reamed. The entire raceway system shall be left clean and clear for installation of CPS Energy conductors.

804.10 Not Permitted Under Buildings or Structures:

Underground service lateral conduits shall not be installed under buildings or structures. Customer shall install metering equipment and provide service disconnecting means and overcurrent protection before service-entrance conductors enter into buildings or structures (Refer to Section 400).

Exception: CPS Energy will review proposed designs where special circumstances may require the use of meter rooms within the building for location of multiple metering equipment. Where CPS Energy approves such designs, Customer shall be responsible for that portion of service conduits under the building or structure. Service conduits under the building or structure shall be installed as required to be considered outside of the building and shall terminate within 4 feet upon entering CPS Energy approved electric meter rooms. CPS Energy may require Customer to install spare conduits and to locate meter rooms on exterior walls as close as possible to transformer poles (Refer to Definition of "Conductors Considered Outside of Building").

804.11 Under Driveways, Parking Lots and Other Drivable Areas:

Where service lateral conduits are to be located underneath a drivable surface, they shall be installed on spacers every 4 feet and be staked down at every 5 to 7 feet. In addition, the conduit installation shall meet the provisions outlined in (1) through (3) below:

- (1) Conduits where crossing under drivable surfaces shall be installed with a minimum cover of 24 inches in private property and a minimum of 36 inches in public right-of-way unless otherwise specified by CPS Energy.

- (2) Trench and conduits shall be backfilled with flowable fill up to no less than 6 inches of pavement surface.
- (3) An inspection by a CPS Energy inspector of all trenching and conduits will be required before backfilling (Refer to Article 804.14).

Note 1: *CPS Energy reserves the right to require removal of backfill and/or flowable fill where Customer backfills without first obtaining the required CPS Energy inspections.*

Note 2: *CPS Energy shall not be responsible for any damage to driveways or other drivable areas as a result of trenching.*

804.12 Conduit Sleeves:

Where Customer needs to install sidewalks, driveways, parking lots or streets prior to the installation of the service laterals and conduits, Customer shall first obtain approval from the CPS Energy Customer Service Representative and then shall install conduit sleeves in accordance with (1) through (6) below:

- (1) Sleeves shall consist of a 6-inch schedule 40 or schedule 80 PVC conduit installed on spacers every 4 feet and staked down at every 5 to 7 feet. One sleeve is required for each underground service lateral conduit specified by CPS Energy to be installed within trench.
- (2) Sleeves shall have a minimum cover of 24 inches in private property and a minimum of 36 inches in public right-of-way unless otherwise specified by CPS Energy.
- (3) Sleeves shall extend a minimum of 12 inches on each side of sidewalks, driveways and parking lots and a minimum of 24 inches if located under streets. Conduit sleeves shall be capped at each end with an approved PVC cap. Customer shall mark on the surface, the beginning and end of each sleeve location, with a stake, hub, pipe, or some other visible marker approved by CPS Energy.
- (4) Other utilities shall not be allowed in a sleeve installed for CPS Energy.
- (5) Trench for conduit sleeves shall be backfilled with approved materials in accordance with CPS Energy specifications.

Note: *For conduit sleeves installed under drivable surfaces, trench, and conduit sleeves shall be backfilled with flowable fill up to no less than 6 inches of pavement surface.*

- (6) All sleeve routes and locations require CPS Energy approval and inspections prior to backfilling (Refer to Article 804.14).

804.13 Clearance from Other Buried Facilities:

Clearance of service conduits from other buried utilities shall be 12 inches minimum for commercial service installations and for residential service installations random lay will be permissible. Depth of trench shall be

coordinated with CPS Energy's Customer Service Representative to assure minimum clearances are maintained.

804.14 CPS Energy Inspections:

The service trench and conduit installation must be inspected by a CPS Energy inspector prior to backfilling the trench. If flowable fill encasement is required, an inspection must be made before pouring the flowable fill and after the flowable fill has been poured. City inspectors or other AHJ inspectors do not perform these inspections. To schedule an inspection, Customer may contact the CPS Energy Customer Service Representative or refer to "Helpful Numbers" listed on the inside front cover page.

Note 1: Where communication utilities are approved to share trench with CPS Energy, a second inspection may be required where flowable fill is interrupted to install such utilities.

Note 2: CPS Energy shall not accept nor take ownership of conduits until after service lateral has been installed.

804.15 Backfill Provisions:

Materials used to backfill a trench shall be clean and free of sharp objects. Customer shall be responsible for backfilling service lateral conduits in accordance with CPS Energy specifications.

805 Service Lateral Conductors and Load:

CPS Energy will furnish, install, and maintain the service lateral conductors to apartment buildings. Each building will be supplied by one service lateral at one point, unless otherwise permitted by CPS Energy in accordance with Section 200 (Refer to Definition of "Building").

805.1 Conductor and Conduit Schedule:

A conductor and conduit schedule shall be issued by the CPS Energy Customer Service Representative that will specify the quantity and size of conduits and conductors required for each service lateral run.

805.2 Termination of Service Lateral Conductors (Point of Delivery):

CPS Energy shall terminate the service lateral conductors onto properly sized and listed terminals or devices furnished by Customer at one of the metering or service equipment locations outlined in (A) through (E) below:

(A) Modular Metering Equipment:

Line-side of Customer furnished and installed modular metering equipment. Modular metering equipment shall be approved by CPS Energy as meeting CPS Energy standards and specifications. Customer shall coordinate the review and approval of modular metering equipment prior to purchase with the CPS Energy Customer Service Representative (Refer to Section 1800).

(B) Independent Main Disconnecting Device:

Line-side of Customer furnished and installed main service disconnecting means (device) installed ahead of auxiliary gutter supplying metering equipment. The Customer's main disconnecting means shall be provided with lockable and sealable means for use by CPS Energy.

(C) Step-Bus Auxiliary Gutter:

Directly on bus within Customer furnished and installed step-bus auxiliary gutter meeting CPS Energy's standards and specifications. Step-bus gutter shall be provided with lockable and sealable means for use by CPS Energy where installed ahead of CPS Energy metering equipment.

Note: Step-bus gutter is required any time service lateral conductors or any one set of service-entrance conductors exceed parallel 350 KCM conductors or single 500 KCM conductors.

(D) Junction/Pull Box (Underground Installations):

Directly to Customer's service-entrance conductors within junction box required by CPS Energy ahead of an auxiliary wire gutter. The junction box shall be sized and installed in accordance with Figure 800.2 and shall be provided with lockable and sealable means for use by CPS Energy due to unmetered conductors. Junction box and auxiliary gutter shall be furnished and installed by Customer.

Exception: Junction box is not required ahead of auxiliary wire gutters serving duplex installations where gutters have minimum dimensions of 16 inches (H) x 8 inches (D) by appropriate length required to extend under each meter socket.

(E) Self-Contained Meter Socket or Instrument Transformer Enclosure:

For one meter installations on the line-side of an individual self-contained meter socket or at the load-side of current transformers where required (Refer to Section 1800).

Note: CPS Energy shall first approve one of the above locations and shall designate location as the POD.

806 Service-Entrance Conductors:

Customer is responsible for furnishing and installing all service-entrance conductors on the load-side of the POD as outlined in Article 805.2.

806.1 Size:

Service-entrance conductors shall have sufficient ampacity to carry the load as determined by the NEC and other applicable codes, but shall not be smaller than No. 8 AWG copper or No. 6 AWG aluminum. Conductor sizes and quantities shall not exceed those allowed for meter sockets or other CPS Energy metering equipment.

806.2 Identification:

Customer shall clearly and permanently identify the grounded (neutral) conductor(s) at all equipment locations and before CPS Energy connects the service lateral (Refer to Section 400).

807 Approved Meter Locations: (Refer to Figure 800.1.)

All metering equipment shall be installed on the exterior of building or structure at a location approved by the CPS Energy and in accordance with Section 1800. Customer shall provide CPS Energy an approved space on the building wall or structure for metering equipment (Refer to Figure 800.2).

Exception 1: Customer may enclose CPS Energy meters in meter closets located on outside walls of the building. The design of the closets shall have prior approval from CPS Energy's Customer Service Representative. Meter closets shall be constructed so as to provide the required working clearances about electrical metering and service equipment (Refer to Section 1800).

Exception 2: CPS Energy will review proposed designs where special circumstances may require the use of meter rooms within the building for location of multiple metering equipment. Where CPS Energy approves such designs, Customer shall be responsible for that portion of service conduits under the building or structure. Service conduits under the building or structure shall be installed as required to be considered outside of the building and shall terminate within 4 feet upon entering CPS Energy approved electric meter rooms. CPS Energy may require Customer to install spare conduits and to locate meter rooms on exterior walls as close as possible to transformer poles (Refer to Definition of "Conductors Considered Outside of Building").

Note 1: In all cases, Customer shall furnish typical meter loop drawings that shall indicate disconnect device ratings, conduit and wire sizes at all points, meter socket ampere ratings, gutter sizes, grounding electrode connections, and the building(s) served by the typical design.

Note 2: Modular metering shall have prior approval from CPS Energy's Electric Service Standards Section and meet minimum CPS Energy specifications. Manufacturer's specifications shall be submitted for modular metering equipment including associated service disconnects indicating the manufacturer's name and the equipment model/catalog designation with line-side lug specifications.

Note 3: Customer shall not install single-phase meter sockets and modular metering equipment on the same apartment complex.

FIGURE 800.1
TYPICAL ELECTRIC DISTRIBUTION IN APARTMENT COMPLEX

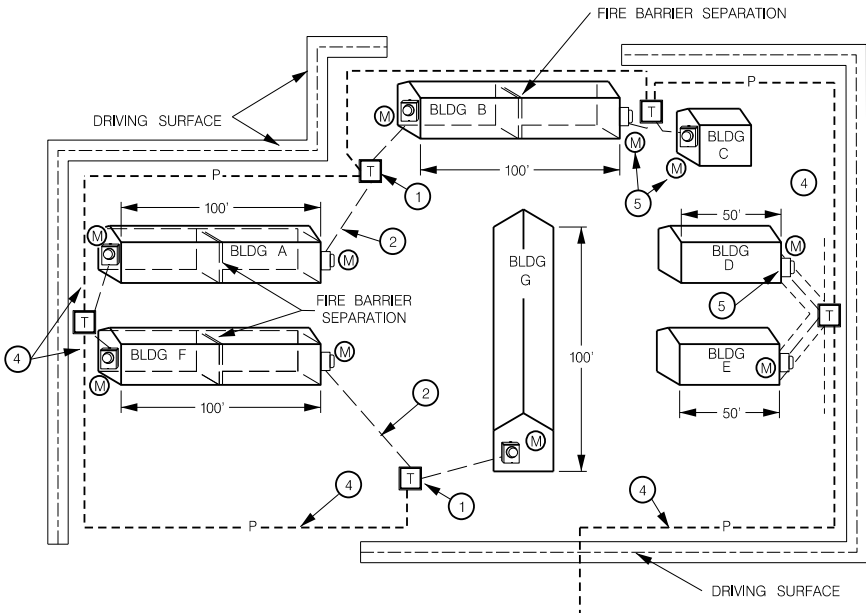

NOTES:

1. CPS ENERGY TRANSFORMERS (T) LOCATED ON PERIMETER OF APARTMENT COMPLEX AND NEAR A HARD DRIVING SURFACE.
2. SECONDARY VOLTAGE SERVICE LATERALS IN ONE OR TWO 3-INCH SCHEDULE 40 OR 80 PVC CONDUIT, REQUIRES A BURIED DEPTH OF 24 INCHES, CUSTOMER FURNISHES AND INSTALLS CONDUIT AS SPECIFIED BY CPS ENERGY. CPS ENERGY FURNISHES AND INSTALLS SERVICE LATERAL CONDUCTORS. SERVICE LATERALS SHALL NOT BE INSTALLED UNDER BUILDINGS OR OTHER STRUCTURES.
3. BUILDINGS IN EXCESS OF 100 FEET IN LENGTH, AND WHOSE SERVICES ARE LOCATED A MINIMUM OF 100 FEET APART MAY BE SERVED WITH TWO SERVICE LATERALS IF A MINIMUM TWO-HOUR FIRE BARRIER, BASED ON ADOPTED BUILDING CODES OF THE AUTHORITY HAVING JURISDICTION IS CONSTRUCTED BY CUSTOMER BETWEEN THE SERVICE POINTS. THE AUTHORITY HAVING JURISDICTION SHALL ENFORCE THIS REQUIREMENT.
4. ALL CPS ENERGY- OWNED AND MAINTAINED PRIMARY VOLTAGE CONDUCTORS (P), TRANSFORMERS, SERVICE LATERAL CONDUCTORS AND METERS SHALL BE READILY ACCESSIBLE AND BE IN EASEMENTS FURNISHED WITHOUT CHARGE BY CUSTOMER TO CPS ENERGY.
5. METERS (M) SHALL BE GROUPED AT SERVICE POINTS ON BUILDING ENDS. THEY SHALL NORMALLY BE MOUNTED OUTDOORS ON WALLS.
6. WHERE MORE THAN ONE SERVICE SUPPLIES A BUILDING, THE AREA SERVED BY EACH MUST BE SEPARATED BY A 2- HOUR FIRE BARRIER CONSTRUCTED IN ACCORDANCE WITH ADOPTED BUILDING CODES. HOUSE LOADS SERVED FROM EACH ARE TO BE INCLUDED AND THUS MAY REQUIRE INDIVIDUAL HOUSE METERS.

FIGURE 800.2
 UNDERGROUND SERVICE AND METERING IN APARTMENT COMPLEXES
 AND SIMILAR MULTIPLE OCCUPANCY BUILDINGS

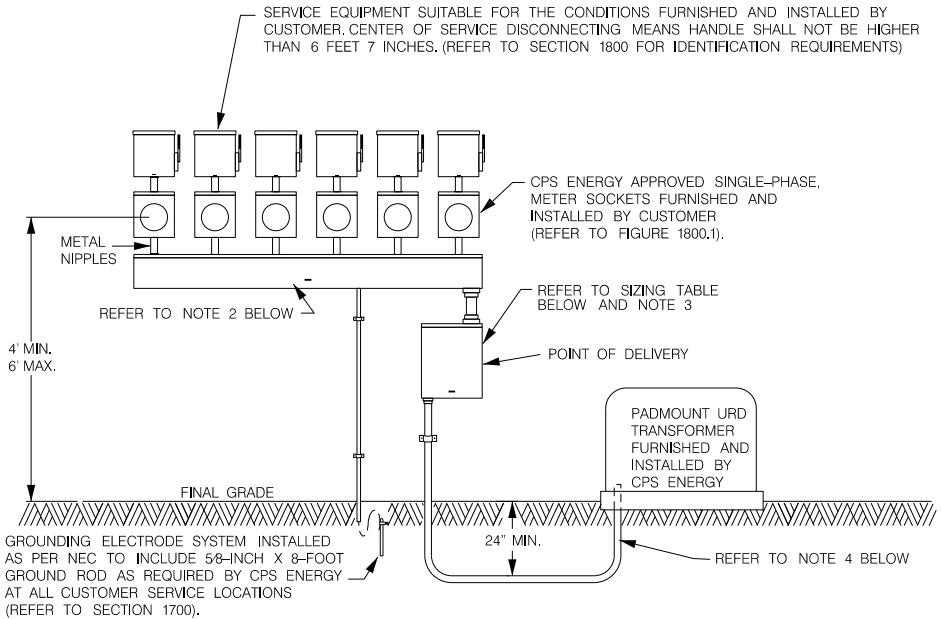

JUNCTION /PULL BOX SIZING TABLE			
LINE-SIDE SIZE CONDUIT SIZE INCHES	MINIMUM DIMENSIONS OF JUNCTION/PULL BOXES (INCHES)		
	HEIGHT	WIDTH	DEPTH
2 1/2 AND 3	24	14	8
3 1/2 AND 4	36	18	10

1. NOTES:

CPS ENERGY WILL INSTALL ON CUSTOMER'S PREMISES SINGLE-PHASE PADMOUNT TRANSFORMERS SUPPLIED BY PRIMARY VOLTAGE CABLE. CPS ENERGY WILL FURNISH AND INSTALL SECONDARY SERVICE LATERAL CONDUCTORS TO THE METERING CENTERS. ALL CPS ENERGY EQUIPMENT MUST BE LOCATED WITHIN CUSTOMER-FURNISHED EASEMENTS. CUSTOMER MUST ARRANGE METERING EQUIPMENT TO ACCEPT SERVICE LATERAL.

2. METAL AUXILIARY GUTTER WITH LOCKABLE MEANS SIZED PER NEC AND FURNISHED AND INSTALLED BY CUSTOMER. (CUSTOMER FURNISHES ALL WIRE IN GUTTER AND IN SOCKETS AND MAKES ALL CONNECTIONS)

3. CUSTOMER-FURNISHED METAL JUNCTION /PULL BOX WITH LOCKABLE MEANS SIZED PER SIZING TABLE ABOVE SHALL BE REQUIRED FOR INSTALLATIONS CONSISTING OF TWO TO SIX METERS SUPPLIED BY CPS ENERGY-OWNED SERVICE LATERAL (REFER TO FIGURE 1800.17)

EXCEPTION:

- A.) DUPLEX INSTALLATIONS UTILIZING A METAL AUXILIARY GUTTER SIZED 16" (H) BY 8" (D) OR LARGER
- B.) STEP-BUS AUXILIARY GUTTERS ARE UTILIZED.
- C.) MAIN DISCONNECT OR MODULAR METERING EQUIPMENT ARE UTILIZED.

4. CUSTOMER FURNISHES AND INSTALLS CONDUIT AND CPS ENERGY FURNISHES AND INSTALLS SERVICE LATERAL CONDUCTORS. STANDARD CONDUIT IS 3-INCH PVC SCHEDULE 40 OR SCHEDULE 80 PVC RATED FOR ABOVE GROUND OR UNDERGROUND.

5. ON OVERHEAD TO UNDERGROUND SERVICES, PLEASE REFER TO FIGURE 600.2 FOR INSTALLATION DETAILS.

FIGURE 800.3
UNDERGROUND SERVICE FROM OVERHEAD FACILITIES

JUNCTION /PULL BOX SIZING TABLE				
LINE-SIDE SIZE	CONDUIT SIZE INCHES	MINIMUM DIMENSIONS OF JUNCTION/PULL BOXES (INCHES)		
		H	W	D
2 1/2 AND 3		24	14	8
3 1/2 AND 4		36	18	10

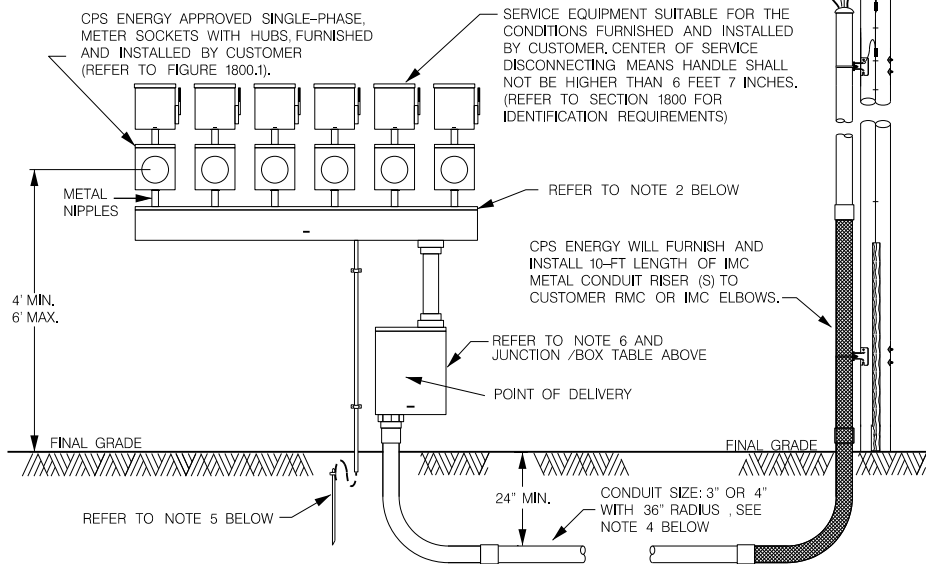

NOTES:

1. CPS ENERGY WILL FURNISH AND INSTALL SECONDARY SERVICE LATERAL CONDUCTORS TO JUNCTION BOX.
2. METAL AUXILIARY GUTTER WITH LOCKABLE MEANS SIZED PER NEC AND FURNISHED AND INSTALLED BY CUSTOMER. (CUSTOMER FURNISHES ALL WIRE FROM JUNCTION BOX TO GUTTER AND IN SOCKETS AND MAKES ALL CONNECTIONS)
3. SERVICE LATERAL CONDUCTORS MUST BE INSTALLED IN CONDUIT. CUSTOMER FURNISHES AND INSTALLS CONDUIT IN ACCORDANCE WITH CPS ENERGY SPECIFICATIONS.
4. STANDARD CONDUIT IS 3- INCH PVC SCHEDULE 40 OR SCHEDULE 80 PVC RATED FOR ABOVE GROUND OR UNDERGROUND USE. MINIMUM ELBOWS RADIUS IS 24 INCHES. SOME SINGLE-METER INSTALLATIONS MAY, WITH CPS ENERGY APPROVAL, HAVE 2 1/2- INCH CONDUIT.
5. GROUNDING ELECTRODE SYSTEM INSTALLED AS PER NEC. TO INCLUDE 5/8-INCH X 8-FOOT GROUND ROD AS REQUIRED BY CPS ENERGY AT ALL CUSTOMER SERVICE LOCATIONS (REFER TO SECTION 1700).
6. CUSTOMER-FURNISHED METAL JUNCTION /PULL BOX WITH LOCKABLE MEANS SIZED PER SIZING TABLE ABOVE SHALL BE REQUIRED FOR INSTALLATIONS CONSISTING OF TWO TO SIX METERS SUPPLIED BY CPS ENERGY- OWNED SERVICE LATERAL (REFER TO FIGURE 1800.17.)
EXCEPTION: CUSTOMER-FURNISHED JUNCTION PULL BOX SHALL NOT BE REQUIRED UNDER ANY OF THE CONDITIONS BELOW:
A.) DUPLEX INSTALLATIONS UTILIZING A METAL AUXILIARY GUTTER SIZED 16" (H) BY 8" (D) OR LARGER
B.) STEP-BUS AUXILIARY GUTTERS ARE UTILIZED.
C.) MAIN DISCONNECT IS SUPPLIED AHEAD OF GUTTER.

SECTION 900

SERVICE IN HIGH-RISE RESIDENTIAL BUILDINGS



SERVICE IN HIGH-RISE
RESIDENTIAL BUILDINGS



901 General:

This type of service is designed for high-rise residential buildings where individual electric metering is installed on upper building levels. The electric supply to upper levels may be secondary or primary voltage. A Customer desiring such a system for a high-rise residential building shall contact the CPS Energy Customer Service Representative for proper coordination. The general requirements for such installations are outlined herein (Refer to Definition of "High-Rise Building").

902 Secondary Voltage Distribution System: (Refer to Figure 900.1)

This type of installation typically involves a three-phase CPS Energy transformer located outside at ground level supplying Customer owned service equipment located outside or inside of building. Customer owned service equipment supplies riser feeders to CPS Energy approved meter rooms located on every third floor and also supplies all house loads within building.

Note: House loads shall be metered separately and such metering equipment shall be located at the Customer service equipment location.

902.1 CPS Energy Service Voltage Supply:

Service voltages will normally be supplied by CPS Energy from a three-phase padmount transformer whose installation shall be in accordance with Section 1000 and Figure 1000.2. Voltage supplied by CPS Energy will be 208Y/120-volt, four-wire wye system.

Note: Customer shall be responsible for providing the necessary load information to verify that all three-wire, single-phase taken for residential loads from this four-wire wye system is balanced.

902.2 Customer Owned Service Lateral and Conduits:

Customer will be responsible for furnishing and installing the service lateral and conduit(s) from CPS Energy owned transformer to their service equipment.

Note: Where the service lateral is to be installed to service equipment located indoors, conductors shall be installed in a manner that will render them outside of the building and shall terminate immediately upon entering an electrical room approved by CPS Energy (Refer to Definition of "Conductors Outside of Building").

902.3 Customer Owned Service Equipment:

Customer shall furnish, install, and maintain service equipment at a readily accessible location approved by CPS Energy outside or inside of building.

(A) Provisions for Tenant Loads:

Customer owned service equipment shall be designed and used to supply feeder risers to metering equipment located in CPS Energy approved meter rooms located on every third floor within building. Customer shall be responsible for balancing all tenant loads on the 208Y/120-volt, four-wire wye service supplied by CPS Energy.

(B) Provisions for House Loads:

Customer owned service equipment shall be designed with an isolated and dedicated compartment for CPS Energy metering equipment that will be used to

separately meter house loads. Customer shall supply house loads with 208Y/120-volt, four-wire wye service from Customer owned service equipment (Refer to Section 1800 for requirements of metering equipment in Customer owned switchgear).

Exception: *Where justified by demand load, and with special approval of CPS Energy, house loads may be supplied from a separate 480Y/277-volt, four-wire wye transformer supplied by CPS Energy. Customer's 480Y/277-volt service equipment shall be co-located with Customer's 208Y/120-volt service equipment. Metering for house loads served with this type of service may be located at the transformer secondary or at Customer's service equipment location.*

902.4 Feeder Risers Supplying Meter Rooms:

Each feeder riser raceway shall include all of the ungrounded (phase) conductors plus the neutral conductor, and the conductors shall extend into the disconnecting device ahead of grouped meters in each meter room.

(A) Feeder Conductors:

Conductors shall be sized and supported as specified by the NEC. Customer shall be responsible for submitting calculations to the CPS Energy Customer Service Representative that verifies the voltage drop at metering equipment does not exceed 2.5 percent (Refer to Section 300).

(B) Feeder Raceways:

The raceways used for the feeder conductors inside building shall be rigid metal conduit (RMC) or intermediate metal conduit (IMC). Where busway is used, it shall be non-ventilated and accessible for maintenance by CPS Energy. Raceways shall be continuous from the source of supply taken at Customer's service equipment on the ground floor to Customer's disconnecting device ahead of metering in pre-approved meter room on every third floor. All couplings shall be threaded.

902.5 Meter Room Disconnecting Means (Device):

Customer shall furnish, install, and maintain a readily accessible fused disconnect switch or circuit breaker in meter room ahead of grouped metering equipment. Disconnecting means shall be installed within 6 feet of point of penetration by Customer's feeder conductors into meter rooms. A modular metering unit's main disconnecting means shall be acceptable for this purpose.

902.6 Metering Equipment:

Customer's design drawings shall include proposed metering equipment on the load-side of meter room disconnecting means that will be used to supply tenant loads (Refer to Article 904).

903 Primary Voltage Distribution System: (Refer to Figure 900.2.)

Where Customer determines that it is not feasible to have a secondary voltage distribution system and still meet CPS Energy's voltage drop requirements in a high-rise residential building, then Customer may request a primary voltage distribution system.

This type of installation typically involves a primary three-phase padmount switchgear and three-phase padmount transformer installed by CPS Energy at

ground level outside of building. The primary three-phase padmount switchgear will supply single-phase transformer rooms located on every third floor for tenant loads and the three-phase padmount transformer will supply Customer owned service equipment at a CPS Energy approved location for house loads.

Note 1: *House loads shall be metered separately and such metering equipment may be located at the transformer secondary or at Customer's service equipment location.*

Note 2: *CPS Energy will not offer a primary voltage distribution system unless a minimum of six transformer rooms are required, and each transformer room shall serve three floors with a combined load not to exceed 250 kVA.*

903.1 Easements for CPS Energy Equipment:

Easements shall be as specified by CPS Energy and will be required for all CPS Energy equipment located outside and inside building.

903.2 Primary Voltage Ductline and Conductors to CPS Energy Equipment Outside Building:

Customer shall furnish and install the underground ductline that is used to contain the primary voltage conductors from the CPS Energy distribution line to the primary three-phase padmount switchgear/transformer on Customer's premises. Its installation shall be in accordance with Section 1000. CPS Energy will furnish, install, and maintain the primary voltage conductors to the primary three-phase padmount switchgear/transformer equipment.

903.3 CPS Energy Equipment Located Outside of Building:

The padmount switchgear and padmount transformer shall be furnished and installed by CPS Energy outdoors on a common concrete slab. Customer shall be responsible for the cost of the padmount switchgear and for furnishing and installing the common concrete slab to meet CPS Energy specifications. A set of single-phase switches in the padmount switchgear will feed the three individual phases that will serve the URD transformers located in the transformer rooms throughout the building. The three-phase padmount switchgear and the three-phase padmount transformer will each be fed from a separate primary riser or source.

903.4 Service Lateral from Transformer to Customer Owned Service Equipment to Supply House Loads:

Customer will be responsible for furnishing and installing the service lateral and conduit(s) from padmount transformer to Customer owned service equipment inside or outside of building. Service lateral shall be sized and installed in accordance with NEC and other applicable codes.

Note: *Where the service lateral is to be installed to service equipment located indoors, conductors shall be installed in a manner that will render them outside of the building and shall terminate immediately upon entering an electrical room approved by CPS Energy (Refer to Definition of "Conductors Outside of Building").*

A) Customer Owned Service Equipment:

Customer shall be responsible for furnishing and installing service equipment at a readily accessible location inside or outside of building for termination of the service lateral. Customer shall coordinate with the CPS Energy

Customer Service Representative for location of service equipment. Service equipment shall be sized and installed in accordance with NEC and other applicable codes.

(B) Metering for House Loads:

House loads shall be metered separately and such metering equipment shall be at a location approved by CPS Energy either at the CPS Energy transformer or at Customer's service equipment location. Customer shall be responsible for coordinating with the CPS Energy Customer Service Representative on location and for installation of metering equipment.

903.5 Primary Voltage Circuits Supplying Transformer Rooms:

Each primary voltage circuit from CPS Energy's padmount switchgear shall be installed in a raceway(s) approved by CPS Energy to the transformer rooms.

CPS Energy will furnish, install, and maintain the primary voltage conductors to the transformer rooms. Each room will be served from one phase and the neutral of the three-phase system by use of radial feed primary cable runs.

903.6 Raceways to Transformer Rooms:

Customer shall furnish, install, and maintain the riser raceways for enclosing the CPS Energy primary voltage conductors between transformer rooms.

(A) Approved Type:

Each raceway for primary voltage conductors and grounding conductors shall be Rigid Metal Conduit (RMC), Intermediate Metal Conduit (IMC), Rigid Polyvinyl Chloride Conduit (PVC), schedule 40 or schedule 80 rated for 90 degrees Celsius.

(B) Number of Conduits:

A separate conduit shall be installed for each phase of the primary voltage conductors. A fourth conduit shall be installed for CPS Energy's grounding conductors.

(C) Size:

Conduit size shall be 4 inches for primary voltage conductors and shall have not less than 36-inch radius bends and no more than 270 degrees of bends total. The fourth conduit used for CPS Energy's grounding conductors shall be a minimum of 2 inches.

(D) Installation:

Conduits shall be installed in a manner that will render them outside of building (Refer to Definition of "Conductors Considered Outside of Building").

Exception 1: *CPS Energy may allow short continuous sections of RMC or IMC conduits to be installed from padmount switchgear to dedicated riser shafts within the building.*

Exception 2: *Where conduits are inside of transformer rooms.*

In addition to conduits being installed in a manner rendering them outside of building, conduit installation shall also comply with the provisions below:

- (1) Conduits shall be grouped, and each conduit shall have 3 inches minimum spacing from adjacent conduits.
- (2) All conduits shall be located in a corner or side of the transformer rooms away from the doorway and ventilation ducts. It shall be on left side of the transformer room facing through the doorway from outside the room.
- (3) Where conduits enter and leave stacked transformer rooms, they shall be in vertical alignment, terminate 12 inches above floor level and be flush at ceilings.
- (4) Customer shall seal all conduit entrances for the purpose of stopping the intrusion of water.
- (5) Customer shall install an appropriate pull wire or equivalent in each conduit. CPS Energy will install the necessary equipment in each transformer room for cable support.
- (6) Customer shall install a 7/8-inch galvanized pull iron in the ceiling as near as practical over each conduit entrance in the floor for pulling and supporting cables.

903.7 Transformer Rooms:

Customer shall furnish and install transformer rooms in a stacked manner to allow primary circuits to utilize common riser shafts. Common riser shafts shall serve as dedicated easements for CPS Energy's primary voltage supply to single-phase transformers. General requirements are as indicated in (A) through (G) below:

(A) Location:

Where practical, transformer rooms should be located on outside walls with direct access to natural air ventilation. Transformer rooms should be close to load centers for minimum voltage drop and also should be close to electric meter rooms. The transformer room location should minimize the effect of transformer and ventilator motor noise on residential areas. A location near elevators is preferred.

(B) Building Access Requirements to Transformer Rooms:

- (1) Customer shall provide a minimum 4 feet wide by 7 feet high, unrestricted passageway with floor capable of supporting 2500 pounds concentrated load (300-PSI) from outside the building to each transformer room.
- (2) Customer shall provide an elevator with minimum rated capacity of 2500 pounds for delivery of CPS Energy transformers to the transformer rooms on the various levels of the building. This elevator shall be labeled "Freight/Personnel" to distinguish it from other elevators in the building. Minimum elevator door openings shall be 48 inches wide by 84 inches high.

(C) Restricted Access to Transformer Rooms:

Except for the installation of Customer's conductors that are connected to the secondary side of CPS Energy's transformers, transformer rooms are only for the installation of CPS Energy owned equipment. Customer shall not install any devices, raceways, boxes, fixtures, etc. in the transformer rooms unless such equipment is required for the operation of the rooms. Only CPS Energy personnel are permitted access to transformer rooms.

(D) Noise Reduction:

CPS Energy will install its transformers on vibration absorbing mountings. Oil type transformers will be used and they may have a noise level of approximately 45 decibels, 60 Hertz. Customer shall provide any additional soundproofing material within the transformer room to contain the noise. Soundproofing materials shall be non-flaking and fire resistant. Customer shall assume all responsibility for noise from transformer rooms.

(E) Structural:

Customer shall construct transformer room floors and 12-inch elevated transformer slabs to support a weight of 2500 pounds load concentrated in an area with dimensions of 48 inches x 48 inches. Transformer room walls shall be masonry and suitable for equipment mounting. The transformer room shall conform to NEC requirements for "Transformer Vaults" and also meet CPS Energy requirements.

(F) Size of Transformer Room:

Normally only one transformer will be placed in a stacked transformer room. The minimum inside dimensions of a transformer room without vertical ventilation ducts shall be 8 feet high x 9 feet wide x 7 feet deep. Where vertical ventilation ducts are used, additional space will be required.

(G) Doorways:

- (1) Minimum door opening shall be 4 feet wide x 7 feet high.
- (2) Doors shall swing out from transformer room and personnel doors shall be equipped with panic bars, pressure plates or other devices that are normally latched but open under simple pressure, per NEC and applicable codes. If double doors are used, the second door shall be fitted with surface bolts inside at top and bottom.
- (3) Transformer room floors and walls shall be designed to prevent oil seepage to outside of room. A 12-inch sill will be required under doorway.
- (4) Doors that are tight fitting (no louvers) and have a fire rating as required by NEC shall be installed. Door hinges shall have non-removable pins. Doors shall have cylinder locks keyed to CPS Energy keys or shall have non-removable hasps for CPS Energy padlocks. Only CPS Energy locks shall be on doors. CPS Energy will label, "Danger High Voltage" on the transformer room doors.

(H) Ventilation:

Transformer rooms shall be supplied with ventilation in accordance with the specific requirements outlined in (1) and (2) below:

SECTION 900 - SERVICE IN HIGH-RISE RESIDENTIAL USE BUILDING

- (1) Where practicable, at least one wall of transformer room should be located on an outside building wall. Such transformer rooms shall have one opening through the outside wall for natural air ventilation and another for exhaust, fitted with approved louvers. Where practical, cross ventilation should be used and comply with the following provisions:
 - (a) The openings should be 20 inches in diameter.
 - (b) The lower opening shall be 12 inches from floor.
 - (c) Upper ventilator to exhaust to outside air and be 6 inches below ceiling.
 - (d) Ventilation openings to be installed as far away as possible from doors, windows, fire escapes, and combustible material.
 - (e) Ventilation openings to the interior of the building are not allowed.
 - (f) All openings shall be covered with durable gratings, screens, or louvers, according to the treatment required in order to help avoid unsafe conditions.
 - (g) If fans are required, CPS Energy shall furnish, install, and maintain them.
- (2) Where transformer rooms must be located interior to the building, the following provisions shall apply:
 - (a) Customer shall furnish, install, and maintain ventilation ducts or shafts. Supply ducts or shafts must be separate from exhaust ducts or shafts.
 - (b) Supply and exhaust air from outside the building must be at the minimum rate of 750 cfm per transformer room and must be independent of any other ventilation or air ducts.
 - (c) Ventilation openings to the interior of the building are not allowed.
 - (d) In transformer rooms, intake openings shall be located 12 inches from floor and exhaust openings 6 inches from ceiling.
 - (e) Each duct opening, except those on outside walls, shall be provided with automatic closing dampers of not less than No. 10 MSG steel that operate in response to temperatures in excess of 130 degrees Celsius.
 - (f) All openings shall be covered with durable corrosion resistant screens or gratings.

- (g) The dimensions of the ducts or shafts shall be such that each transformer room will be provided with 750 cfm by natural air ventilation.
- (h) Exhaust fans, if required in the transformer rooms, will be installed and maintained by CPS Energy. All ducts or shafts shall be constructed of non-inflammable material.
- (i) Air from air conditioning systems shall not be used for transformer room ventilation.

903.8 Customer Secondary Service Conductors:

Customer shall furnish the raceway and secondary voltage conductors from each stacked transformer room. Where cable is used, Customer shall provide enough cable to be racked on walls and to reach the terminals of the transformers secondary compartment. Customer shall furnish approved connectors for secondary conductors in accordance with the following:

- (1) For Customer cable sizes No. 4/0 and smaller, Customer may furnish single-barrel, one-hole tongue lugs. CPS Energy will plate all contact surfaces on lugs to industry standards.
- (2) Where Customer cable size exceeds 4/0 and connects to CPS Energy transformer secondary terminals, Customer shall furnish single-barrel, two-hole tongue lugs. Mounting holes in tongue to be 9/16 inches and vertically spaced 1 3/4 inches apart. Lugs width not to exceed 1 3/4 inches and height not to exceed 2 1/4 inches.
- (3) For copper cable, lugs shall be pressure screw type and suitable for the conductors. For aluminum cable, lugs shall be either compression type or two screw pressure type suitable for the conductor.
- (4) If Customer elects to use compression lugs on their cables, they shall provide and install in accordance with manufacturer's specifications.

Note: *Where raceways enter transformer rooms, they shall contain a fire stop. The point of delivery will be at the CPS Energy transformer.*

904 Electric Meter Rooms:

Customer shall furnish CPS Energy approved electric meter rooms, which are separate from transformer rooms, to house necessary disconnecting means and metering equipment approved for use by CPS Energy. Meter rooms shall be readily accessible to authorized CPS Energy personnel and located adjacent to, or above or below, transformer rooms. Metering equipment shall not be installed in transformer rooms.

Meter rooms "shall not be used for storage purposes" or for the installation of equipment other than metering equipment and disconnecting devices. Where space is available and with prior CPS Energy approval, cable television and telephone terminal boards may also be installed (Refer to Section 1800).

Customer shall furnish, install, and maintain adequate lighting in each electric meter room. The lighting circuit shall be supplied from an emergency

power source where such a system is available or from a source outside the electric meter room where an emergency power source is not available.

904.1 Meter Room Disconnecting Means (Device):

Customer shall furnish, install, and maintain a readily accessible fused disconnect switch or circuit breaker in meter room ahead of grouped metering equipment. Disconnecting means shall be installed within 6 feet of point of penetration by the Customer's feeder conductors into meter rooms. A modular metering unit's main disconnecting means shall be acceptable for this purpose.

904.2 Metering Equipment:

Customer design drawings shall include proposed metering equipment on the load-side of meter room disconnecting means that will be used to supply tenant loads (Refer to Article 904).

Note: Only pre-approved modular metering equipment shall be permitted to be used with secondary voltage service in High-Rise Residential buildings (Refer to Section 1800).

FIGURE 900.1
TYPICAL HIGH-RISE SECONDARY VOLTAGE DISTRIBUTION SYSTEM

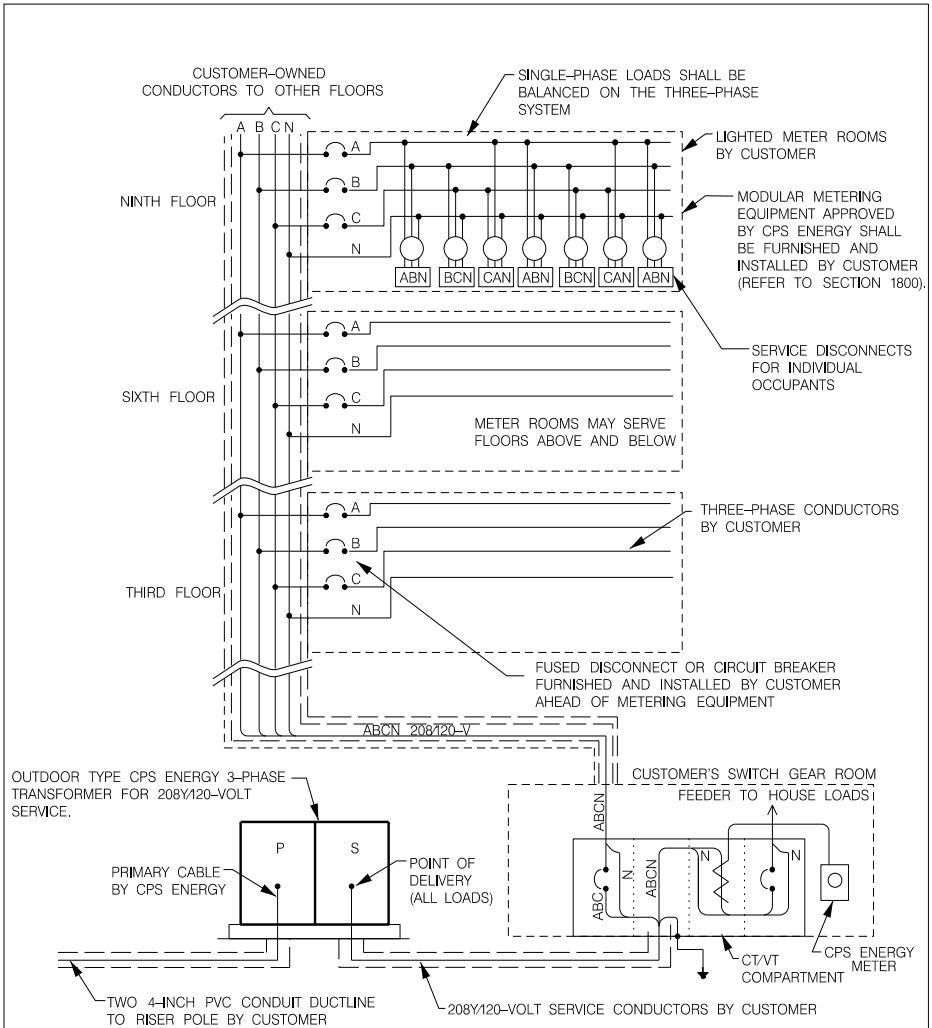

NOTE:

1. CUSTOMER SHALL FURNISH, INSTALL AND MAINTAIN SERVICE EQUIPMENT.
2. CUSTOMER-OWNED SERVICE EQUIPMENT SHALL BE DESIGNED WITH AN ISOLATED AND DEDICATED COMPARTMENT FOR CPS ENERGY METERING EQUIPMENT THAT WILL BE USED TO SEPARATELY METER HOUSE LOADS.
3. CUSTOMER SHALL BE RESPONSIBLE FOR BALANCING ALL TENANT LOADS ON THE 208Y/120-VOLT, FOUR-WIRE SERVICE SUPPLIED BY CPS ENERGY.
4. ONLY PRE-APPROVED MODULAR METERING EQUIPMENT SHALL BE PERMITTED TO BE USED WITH SECONDARY VOLTAGE SERVICE IN HIGH-RISE RESIDENTIAL BUILDINGS.

FIGURE 900.2
TYPICAL HIGH-RISE PRIMARY VOLTAGE DISTRIBUTION SYSTEM

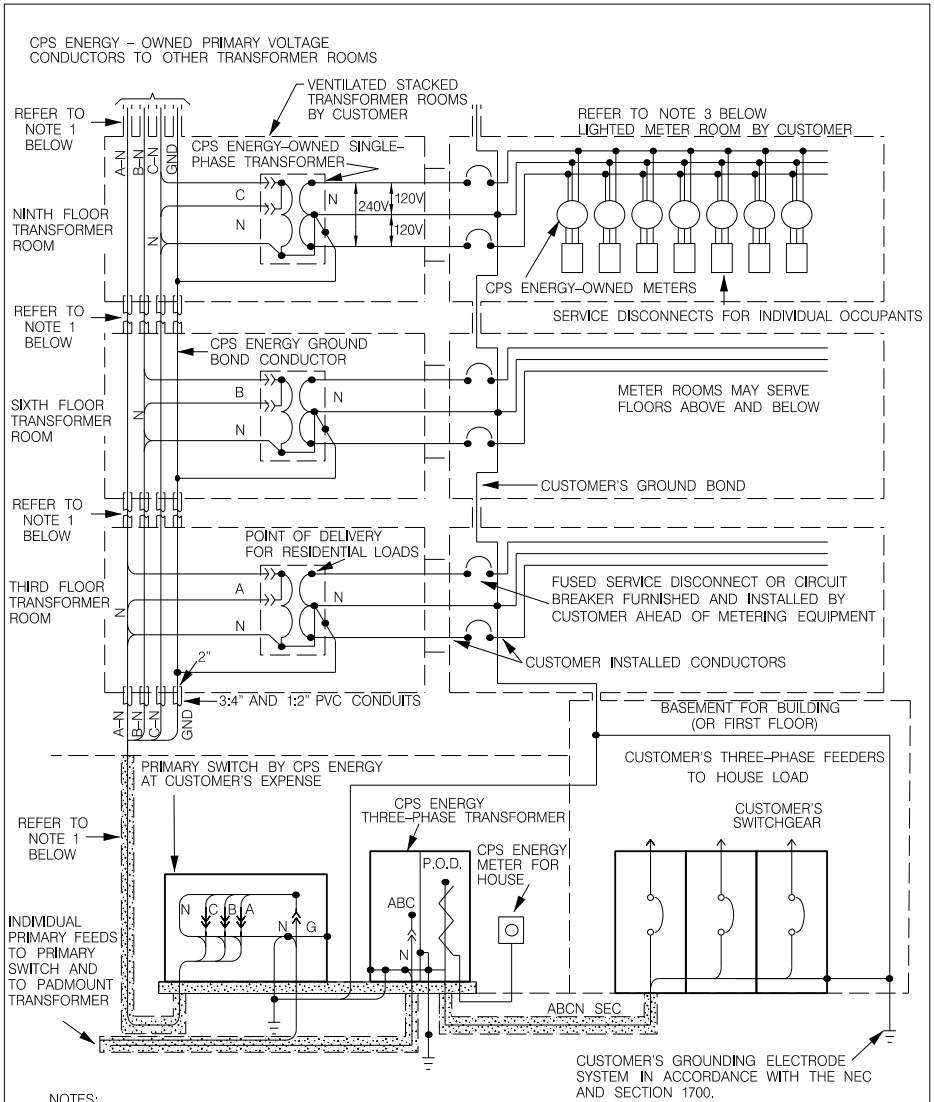

NOTES:

1. ALL RACEWAYS SHALL BE INSTALLED BY CUSTOMER AS TO BE CONSIDERED EFFECTIVELY OUTSIDE THE BUILDING. (REFER TO DEFINITION OF "CONDUCTORS CONSIDERED OUTSIDE OF BUILDING")
2. THE CPS ENERGY THREE-PHASE TRANSFORMER AND PRIMARY SWITCH WILL NORMALLY BE LOCATED OUTDOORS AS SHOWN HERE. THE TRANSFORMER MAY BE 480V/277-VOLT WHEN APPROVED BY CPS ENERGY
3. CUSTOMER SHALL FURNISH CPS ENERGY-APPROVED ELECTRIC METER ROOMS SEPARATE FROM TRANSFORMER ROOMS TO HOUSE CUSTOMER SERVICE EQUIPMENT AND NECESSARY METERING EQUIPMENT.
4. CPS ENERGY SHALL FURNISH AND INSTALL PRIMARY VOLTAGE CABLE IN CONDUITS FURNISHED AND INSTALLED BY CUSTOMER.

SECTION 1000

COMMERCIAL OR INDUSTRIAL SERVICES FROM PADMOUNT TRANSFORMERS



**COMMERCIAL OR INDUSTRIAL SERVICES
FROM PADMOUNT TRANSFORMERS**



SECTION 1000 - COMMERCIAL OR INDUSTRIAL SERVICE FROM PADMOUNT
DISTRIBUTION TRANSFORMER

1001 General:

This type of service typically consists of underground primary voltage cables connected to the electric distribution system and installed in concrete encased conduit to CPS Energy owned three-phase padmount transformer located on Customer premises. Service is supplied to Customer from the padmount transformer's secondary terminals.

1001.1 Demand Loads Over 300 kVA:

A standard padmount transformer installation is intended for a commercial or industrial Customer, or group of such Customers, whose demand load exceeds 300 kVA. CPS Energy will determine the rating of the transformer required to serve the Customer.

1001.2 Demand Loads 300 kVA and Under:

Where Customer demand load is 300 kVA or less, and a padmount transformer is requested, the Customer will be required to pay the cost difference from that of an overhead transformer bank which could serve their load.

1001.3 CPS Energy Job Sketch:

A Customer desiring service from a padmount transformer shall make arrangements for it with a CPS Energy Customer Service Representative. When all requirements have been met, CPS Energy will issue a detailed construction sketch to Customer for the construction of the transformer slab and associated ductbank.

1002 Standard Installation:

A standard installation for service from a padmount transformer will typically consist of the following:

1002.1 Primary Voltage Cable:

(A) From Overhead Distribution Circuits:

Primary voltage cables from CPS Energy's overhead distribution circuit to the primary terminals of the padmount transformer will be furnished and installed by CPS Energy. CPS Energy will install a riser pole for the purpose of making the transition from the overhead circuit conductors to underground cable to supply the padmount transformer.

(B) From Underground Distribution Systems:

Primary voltage cables from an underground distribution circuit to the primary terminals of the transformer will be furnished and installed by CPS Energy. In underground distribution systems, the primary voltage cables that serve a padmount transformer will either originate from a three-phase padmount switchgear directly or may be spliced into the existing primary voltage cables of the underground system. Customer shall coordinate with the CPS Energy Customer Service Representative to determine service availability options from existing underground distribution systems.

1002.2 Primary Ductline:

The primary voltage cables shall be installed in concrete encased conduits (ductline) from the riser pole or other source up to the transformer slab. Customer shall install the ductline in accordance with the standards outlined in this section and other drawings/specifications issued by CPS Energy for each three-phase padmount service installation. The conduits shall be

SECTION 1000 - COMMERCIAL OR INDUSTRIAL SERVICE FROM PADMOUNT
DISTRIBUTION TRANSFORMER

continuous except for watertight couplings and shall be left clean with both ends plugged. Customer shall be responsible for furnishing all materials required for the installation of the ductline, including conduits, spacers, and concrete.

(A) Number of Conduits:

The standard ductline installation for a radial feed to a padmount transformer shall consist of two 4-inch concrete encased conduits. For looped feeds, the standard ductline to a padmount transformer shall consist of three 4-inch concrete encased conduits; however, the main ductline shall be designed with the necessary number of conduits to accommodate future growth.

(B) Routing and Separation from Other Utilities:

Customer will submit a proposed ductline route and length for review and approval by CPS Energy. The ductline may not be installed under any permanent structure or building. In addition, the ductline must have a minimum of 12 inches of vertical separation from any utility and 36 inches of horizontal separation.

(C) Ductline Length:

The minimum distance between riser pole and closest edge of transformer slab is 15 feet. The maximum ductline length will be limited by the primary cable pulling tensions and will be determined by the CPS Energy Customer Service Representative. If a proposed ductline length would result in the maximum allowable cable pulling tensions being exceeded, then the ductline length will have to be reduced, or one or more Customer furnished manholes will be required.

(D) Transposition of Conduits in Ductline:

In cases where three 4-inch conduits are installed, two of the conduits in the ductline may need to be transposed in order to establish standard phasing at the transformer. This transposition will be indicated on the CPS Energy Job Sketch and will typically occur at the base of the riser pole.

(E) Approved Conduit Types:

The standard installation for underground ductlines shall consist of PVC conduits, schedule 40 or schedule 80, rated for 90 degrees Celsius temperature, listed for aboveground and underground use. The elbows at the riser pole shall be schedule 80 and they shall be equipped with unthreaded PVC female adapters. CPS Energy may require that rigid metal conduit (RMC) or intermediate metal conduit (IMC) elbows be installed by the Customer at the riser pole.

(F) Installation:

A typical ductline installation shall consist of PVC conduits arranged horizontally in a trench with conduit spacers every 4 feet and totally encased in 3 inches of 2000-PSI pea gravel concrete on all sides. Concrete surfaces above the ductline do not serve for this protection. In addition, ductline installations shall meet the provisions below:

- (1) Trench shall be of adequate depth and width to accommodate the specified ductline dimensions while maintaining a minimum of 30 inches of cover from final grade on private property and a minimum of 36 inches of cover in public right-of-way.

SECTION 1000 - COMMERCIAL OR INDUSTRIAL SERVICE FROM PADMOUNT
DISTRIBUTION TRANSFORMER

- (2) Conduits shall be staked down every 5 to 7 feet to prevent them from floating.
- (3) All joints and couplings shall be water-tight and where applicable, ductlines shall drain to manholes.
- (4) The elbows at the riser pole and transformer slab shall be encased in concrete to the finished grade and slab, respectively.
- (5) All conduits shall be left clean with both ends appropriately plugged in preparation for cable pulling. Customer shall provide a pull string in conduit(s).
- (6) Customer shall align ductline and elbows with the CPS Energy conduit bracket at riser pole and connect the Customer conduits to the CPS Energy riser conduits.

Note: Typically, CPS Energy will install the riser pole prior to the installation of Customer's ductline to allow for proper alignment and coupling to CPS Energy's riser conduits. To facilitate the alignment, CPS Energy will install a conduit bracket on its pole 2 feet from finished grade, plus install a temporary 2-foot length of PVC conduits. Customer shall not disturb the CPS Energy riser conduits except as necessary to align their conduit elbows to the CPS Energy conduits. Customer shall not alter the position of the conduit brackets on the pole.

(G) Backfill Provisions:

Materials used to backfill a ductline trench shall be clean and free of sharp objects. Customer shall be responsible for backfilling trench in accordance with CPS Energy specifications.

Exception: Ductlines installed across streets, or other drivable areas shall be backfilled with flowable fill from the top of the concrete encased ductline to within 6 inches of final pavement surface.

(H) Inspections:

Two inspections are required for concrete encased ductlines. A CPS Energy inspector shall inspect and approve all primary ductlines and manholes before the conduits within the underground ductline are encased in concrete and a second inspection is required before the trench is backfilled. COSA or other AHJ inspectors do not make these inspections. To schedule an inspection, customer may contact the CPS Energy Customer Service Representative or refer to "Helpful Numbers" listed on the inside front cover page.

Note: CPS Energy may require Customer to remove any or all of the backfill and concrete if an inspection was not performed as required.

1002.3 Manholes:

Manholes may be required to be installed by Customer as part of the primary ductline. Materials and design of manholes and their covers shall be in accordance with CPS Energy specifications, which will be provided by the CPS Energy Customer Service Representative. Manholes and their covers must be inspected and approved by CPS Energy after their installation.

SECTION 1000 - COMMERCIAL OR INDUSTRIAL SERVICE FROM PADMOUNT
DISTRIBUTION TRANSFORMER

Note: *CPS Energy may require Customer to remove manhole and/or cover if an inspection was not performed as required or if the installation is not in accordance with CPS Energy's specifications.*

1002.4 Transformer:

The padmount transformer shall be located, and its slab built in accordance with the following general requirements:

(A) Location:

Customer shall provide CPS Energy with an approved location on their premises that is adequate for the transformer installation. Customer shall furnish a site plan or drawing to CPS Energy that establishes the exact location of the transformer slab with respect to permanent and identifiable structures. The location shall provide for the following:

- (1) Open access to transformer both vertically and horizontally by equipment and personnel. Where located behind a wall or fence, the wall or fence may not be taller than 8 feet and must include a minimum 10-foot wide opening in front of transformer.
- (2) A 15-foot wide, all-weather drivable surface up to transformer slab for access by CPS Energy crane. Drivable surfaces shall meet the design criteria outlined by CPS Energy's Underground Engineering Section.
- (3) Allow for 6 feet of clearance in front of transformer's slab (transformer door side) and 3 feet around sides and back. If possible, transformer doors shall face away from buildings or structures.
- (4) Appropriate clearances for transformer away from building openings, stairways, fire escapes, etc.
- (5) No exposure of transformer to corrosive vapors, steam cooling tower discharges, etc. that could damage it.
- (6) Protection by use of removable concrete filled bollards around transformer where it is subjected to vehicular traffic.

(B) Transformer Slab:

The transformer shall be mounted on a steel reinforced 2500-PSI regular concrete slab built by Customer to CPS Energy specifications. In addition, the provisions of (1) through (5) below will be applicable for construction of transformer slabs:

- (1) The top of the slab shall be a minimum of 6 inches and a maximum of 12 inches above final grade.
- (2) There shall be no pipes, conduits, etc. under the slab except those necessary to supply primary to the transformer, those required to supply the electric load, and the 2-inch conduit that may be required for metering that is to be stubbed out from the concrete slab.
- (3) Where the subsoil conditions are questionable, CPS Energy shall require the Customer to provide a Proctor Density Test at their expense to

SECTION 1000 - COMMERCIAL OR INDUSTRIAL SERVICE FROM PADMOUNT
DISTRIBUTION TRANSFORMER

determine if the slab shall be built on piers. A 90 percent Proctor Test is necessary to eliminate the need for piers.

- (4) Customer shall furnish and install two 5/8-inch x 8-foot copper or copper clad ground rods in the slab, as specified in CPS Energy's slab detail. CPS Energy will provide and install all necessary ground rod connectors.
- (5) Where required by CPS Energy, an oil containment pit shall be constructed by Customer in accordance with specifications provided by the CPS Energy Customer Service Representative. Oil containment pits are required where oil capacity exceeds guidelines established by the Environmental Protection Agency (EPA) or the Texas Commission for Environmental Quality (TCEQ).

(C) Inspections:

Two inspections are required for transformer slabs. A CPS Energy inspector shall inspect the slab after forms, reinforcing steel, primary and secondary conduits, metering conduit(s), and ground rods are in place, and the installation is ready for concrete pouring. A second inspection is required after the concrete has been poured and all forms have been removed. COSA or other AHJ inspectors do not make these inspections. To schedule an inspection, Customer may contact the CPS Energy Customer Service Representative or refer to "Helpful Numbers" listed on the inside front cover page.

Note: *CPS Energy reserves the right to require Customer to remove any or all of the concrete and surrounding fill to expose reinforcing steel, footings, etc. when a slab inspection was not obtained prior to it being poured.*

(D) Transformer Installation:

Access to transformer slab by crane, equipment and personnel must be free and clear of obstructions and debris. Transformer slab must cure for a minimum of 72 hours prior to installation of transformer.

1002.5 Secondary Feed to Customer (Service Lateral):

On standard padmount transformer installations, Customer shall furnish, install, and maintain the secondary cables, lugs, and conduits between the secondary compartment of the transformer and Customer service equipment. CPS Energy shall make all connections to transformer secondary terminals.

Note 1: On 4160Y/2400-volt services, Customer shall also furnish CPS Energy with approved cable terminators for their cable. CPS Energy will install the cable terminators and make connections to CPS Energy's transformer.

Note 2: *CPS Energy shall only allow one service lateral from the secondary side of the transformer. Where Customer is approved by CPS Energy to install additional service laterals, Customer must furnish and install a tap box in accordance with (D) below and all laterals will originate from the tap box.*

(A) Busbars in Transformer:

Busbars are not acceptable in the secondary compartment of the transformer.

SECTION 1000 - COMMERCIAL OR INDUSTRIAL SERVICE FROM PADMOUNT
DISTRIBUTION TRANSFORMER

(B) Cable and Connectors in Transformer:

The quantities and sizes of secondary cables that can be connected to CPS Energy transformers are identified in Table 1000.1 (A) and (B) and are dependent on transformer kVA size. Where Customer elects to install cables in excess of that allowed by CPS Energy, the cables shall terminate in a Customer furnished and installed tap box pre-approved by CPS Energy (Refer to (D) below):

- (1) Customer shall furnish single-barrel, two-hole tongue lugs. Mounting holes in tongue to be 9/16 inches and spaced vertically and horizontally 1 3/4 inches center to center. Cable lug width shall not exceed 1 3/4 inches and height shall not exceed 2 1/4 inches.
- (2) For copper cable, lugs shall be pressure screw type and suitable for the conductors. For aluminum cable, lugs shall be compression type suitable for the conductors. Customer shall coordinate with CPS Energy prior to installation of compression lugs on their cables to ensure proper alignment of lugs with transformer secondary terminals and provide the necessary compression tools.

(C) Load-Side Conduits:

The standard installation requires the use of schedule 40 or 80 PVC conduits. CPS Energy will specify and limit the size and number of conduits and the manner in which they exit the transformer's secondary compartment. Conduits are required to exit at the bottom of the transformer through the slab. The maximum number of conduits shall not exceed ten 4-inch conduits or eight 5-inch conduits (Refer to Table 1000.3). Conduits shall not exit the top or side of a transformer.

Exception: Wireways installed with tap box installations shall meet the minimum requirements outlined in (D) below.

(D) Tap Boxes:

Customer furnished and installed tap boxes shall be required where the Customer's secondary load conductors are in excess of those allowed in Table 1000.1 (A) and (B) or where Customer requests and is approved by CPS Energy to install additional service laterals (Refer to Section 200). The point of delivery (POD) will be at cable termination within the tap box.

- (1) Tap box shall be installed at a distance no greater than 3 feet from the side of the transformer's secondary compartment and face same direction as transformer.
- (2) Tap box shall be connected to side of transformer at secondary compartment with a 3-foot long wireway furnished by Customer (Refer to Table 1000.2 for sizing of wireway).
- (3) Wireway must be installed 3 inches above the transformer slab and centered on the side panel of the transformer's secondary compartment. CPS Energy will make the necessary opening into transformer secondary compartment.

SECTION 1000 - COMMERCIAL OR INDUSTRIAL SERVICE FROM PADMOUNT
DISTRIBUTION TRANSFORMER

- (4) Wireways shall not contain removable covers and shall be equipped with casketed flanges secured by nuts and bolts suitable for the condition; self-tapping screws are not permitted.
- (5) Wireways shall be constructed of corrosion resistant steel, primed and painted.
- (6) CPS Energy will furnish, install, and maintain copper secondary cables from the transformer secondary terminals to the tap box. CPS Energy will furnish necessary lugs and make terminations in transformer secondary. Customer will furnish necessary lugs to make terminations in Customer owned tap box.
- (7) Tap box shall be a stand-alone enclosure that is weatherproof and constructed of minimum 12-gauge corrosion resistant steel, primed and painted.
- (8) All tap boxes shall have a step-bus arrangement in accordance with Figure 1000.1 and be designed to allow for equalizing the length of cables on each phase. Busbars must have sufficient number of 9/16-inch holes (non-threaded) to accommodate lugs for connecting the source and service-entrance conductors. Lug mounting holes shall have the standard NEMA vertical and horizontal spacing of 1 3/4 inches.
- (9) Customer shall sufficiently size tap box to accommodate CPS Energy conductors and all Customer conductors.
- (10) Customer shall designate a space in the tap box closest to wireway penetration for CPS Energy to terminate its cables to the busbars. Customer cables and conduits shall not obstruct or interfere with this dedicated space. All connections must be accessible through cable tap box doors (Refer to Figure 1000.1.).
- (11) Customer shall furnish single-barrel, two-hole tongue lugs for termination of all conductors onto bus in tap box. Mounting holes in tongue to be 9/16 inches and vertically spaced 1 3/4 inches apart. Cable lug width shall not exceed 1 3/4 inches and height shall not exceed 2 1/4 inches.
- (12) Each lug used shall be plated to industry standards and shall be a type approved for the conductors and for connection to the busbars. When all components are aluminum (bus and lugs), only aluminum bolts and washers should be used.
- (13) Tap box shall be permanently and legibly marked with the voltage and current rating for which they are designed, and with the manufacturer's name or trademark in such a manner as to withstand the conditions. Such marking shall be located inside on the left side panel near the front of tap box.
- (14) Tap box shall also be equipped with continuous hinge or three barrel hinge cover double doors with stainless steel hinge pins. Door shall be secured by a three-point locking mechanism and a T-handle with provisions for padlocks.

SECTION 1000 - COMMERCIAL OR INDUSTRIAL SERVICE FROM PADMOUNT
DISTRIBUTION TRANSFORMER

- (15) The tap box shall be equipped with padlock hasps for CPS Energy locks and two each pentabolt locking devices located at top and bottom of door assembly properly securing both doors.
- (16) The tap box enclosure shall be effectively grounded in accordance with applicable codes.
- (17) The tap box shall be installed on a concrete slab that is monolithically poured with CPS Energy's transformer slab.
- (18) Tap box drawings shall be submitted to CPS Energy for review and approval prior to installation.

1002.6 Metering:

CPS Energy metering equipment typically consists of transformer rated metering equipment. Instrument transformers are typically installed by CPS Energy in the transformer secondary compartment. The transformer rated meter socket must be installed by Customer as close to the transformer as possible. The installation of the metering equipment shall be as indicated on the CPS Energy Job Sketch. Metering installation requirements will depend on the type of service installation being requested by Customer and are outlined below:

(A) Rack Mounted Meter:

Rack mounted meter installations are available for any type of service installation from a padmount transformer, including tap box installations and multiple metering installations. If the instrument transformers are installed in the secondary compartment of the CPS Energy transformer, the Customer may install the transformer rated meter socket on a meter rack adjacent to the transformer slab and metering conduit length from the transformer to the meter socket shall not exceed 20 feet (Refer to Definition of "Meter Rack" and Figure 1800.20).

(B) Building Wall Mounted Meter:

Meters may be mounted on building walls for any type of service installation from a padmount transformer, including tap box installations and multiple metering installations. If the instrument transformers are installed in the secondary compartment of the CPS Energy transformer, the Customer may install the transformer rated meter socket on a building wall adjacent to the transformer slab and metering conduit length from the transformer to the meter socket shall not exceed 20 feet.

(C) Conduit for Metering Control Cable:

For services where metering is installed on a meter rack or building wall, and instrument transformers are installed in the secondary compartment of the CPS Energy transformer, Customer shall install a 2-inch conduit between the transformer's secondary compartment and the meter enclosure/socket. This conduit must be 24 inches deep and continuous except for watertight couplings. It may be schedule 40 PVC or schedule 80 PVC. Conduit must be clean for cable pulling and appropriately plugged at both ends. CPS Energy will install the meter, provide metering control cable, install the instrument transformers, and make all connections (Refer to Section 1800).

SECTION 1000 - COMMERCIAL OR INDUSTRIAL SERVICE FROM PADMOUNT
DISTRIBUTION TRANSFORMER

Note: Where conduit has been approved to be installed above ground, IMC or Rigid conduit shall be used and size to be specified by CPS Energy.

(D) Load Management Data (Pulse Device):

For single meter installations where Customer requests load management data via a pulse device, the Customer shall install the CPS Energy furnished meter socket and Code 14 metering enclosure on a meter rack or building wall and metering conduit length from the transformer to the meter socket shall not exceed 20 feet (Refer to Definition of "Meter Rack" and Figure 1800.20).

(E) Multiple Metering and Other Installations:

For multiple metering installations, or other CPS Energy approved installations where instrument transformers will not be installed in the secondary compartment of the CPS Energy transformer. All metering equipment shall be located at CPS Energy approved locations in accordance with Section 1800.

Note: *Customer's service disconnecting means shall be located immediately adjacent to metering equipment for each tenant.*

TABLE 1000.1 (A)
MAXIMUM NUMBER OF CONDUCTORS FOR STANDARD PADMOUNT TRANSFORMERS

480Y/277-VOLT THREE-PHASE PADMOUNT TRANSFORMERS												
CPS Energy Standard Padmount Transformer	Maximum Allowable Number and Size in KCM of Conductors Per Phase That Customer May Install in the CPS Energy Padmount Transformer Shown by kVA Rating at Left-Most Column. Note: If These Values Are Exceeded or if Customer's Design Requires Splitting of Load at Transformer, Customer Shall Furnish and Install an Approved Cable Tapbox.										Conductors Per Phase CPS Energy Will Install if a Tapbox is Required	
480Y/277V 3-Phase	Wire Type	1	2	3	4	5	6	7	8	9	10	(-)
150 kVA	CU	500	500	250	4/0							1 - 250 KCM
	AL	750	750	350	250							
300 kVA	CU	600	600	600	600							2 - 250 KCM
	AL	900	900	900	900							
500 kVA	CU	1000	1000	1000	1000	750	750	750	750			2 - 500 KCM
	AL	1000	1000	1000	1000	1000	1000	1000	1000			
750 kVA	CU	1000	1000	1000	1000	750	750	750	750			3 - 500 KCM
	AL	1000	1000	1000	1000	1000	1000	1000	1000			
1000 kVA	CU	1000	1000	1000	1000	750	750	750	750	750	750	4 - 500 KCM
	AL	1000	1000	1000	1000	1000	1000	1000	1000	1000	1000	
1500 kVA	CU	1000	1000	1000	1000	750	750	750	750	750	750	6 - 500 KCM
	AL	1000	1000	1000	1000	1000	1000	1000	1000	1000	1000	
2000 kVA	CU	1000	1000	1000	1000	750	750	750	750	750	750	8 - 500 KCM
	AL	1000	1000	1000	1000	1000	1000	1000	1000	1000	1000	
2500 kVA	CU	1000	1000	1000	1000	1000	1000	1000	1000	1000	1000	10 - 500 KCM
	AL	1000	1000	1000	1000	1000	1000	1000	1000	1000	1000	

208Y/120-VOLT THREE-PHASE PADMOUNT TRANSFORMERS												
CPS Energy Standard Padmount Transformer	Maximum Allowable Number and Size in KCM of Conductors Per Phase that Customer May Install in the CPS Energy Padmount Transformer Shown by kVA Rating at Left-Most Column. Note: If These Values Are Exceeded or if Customer's Design Requires Splitting of Load at Transformer, Customer Shall Furnish and Install an Approved Cable Tapbox.										Conductors Per Phase CPS Energy Will Install if a Tapbox is Required	
208Y/120V 3-Phase	Wire Type	1	2	3	4	5	6	7	8	9	10	(-)
150 kVA	CU	500	500	250	4/0							2 - 350 KCM
	AL	750	750	350	250							
300 kVA	CU	600	600	600	600							3 - 500 KCM
	AL	900	900	900	900							
500 kVA	CU	1000	1000	1000	1000	750	750	750	750			4 - 750 KCM
	AL	1000	1000	1000	1000	1000	1000	1000	1000			
750 kVA	CU	1000	1000	1000	1000	750	750	750	750			6 - 750 KCM
	AL	1000	1000	1000	1000	1000	1000	1000	1000			
1000 kVA	CU	1000	1000	1000	1000	750	750	750	750	750	750	8 - 750 KCM
	AL	1000	1000	1000	1000	1000	1000	1000	1000	1000	1000	

Note 1: Customer shall furnish and install approved cable lugs in their tap box to receive CPS Energy 90 degrees C, conductors from CPS Energy Transformer (Refer to Figure 1000.1).

Note 2: Customer shall submit tap box shop drawings to CPS Energy's Electric Service Standards Section for review and approval prior to installation.

Note 3: Tap box shall be installed in accordance with Section 1000 and serve as the point of delivery.

**TABLE 1000.1 (B)
MAXIMUM NUMBER OF CONDUCTORS FOR COMPACT PADMOUNT TRANSFORMERS**

480Y/277-VOLT THREE-PHASE COMPACT PADMOUNT TRANSFORMERS												
CPS Energy Compact Padmount Transformer	Maximum Allowable Number and Size in KCM of Conductors Per Phase that Customer May Install in the CPS Energy Padmount Transformer Shown by kVA Rating at Left-Most Column. Note: If These Values Are Exceeded or if Customer's Design Requires Splitting of Load at Transformer, Customer Shall Furnish and Install an Approved Cable Tapbox.											Conductors Per Phase CPS Energy Will Install if a Tapbox is Required
480Y/277V 3-Phase	Wire Type	1	2	3	4	5	6	7	8	9	10	(-)
75 kVA	CU	500	500	250	4/0							1 - 250 KCM
	Al	750	750	350	250							
150 kVA	CU	500	500	250	4/0							1 - 250 KCM
	AL	750	750	350	250							
225 kVA	CU	600	600	500	500							2 - 250 KCM
	AL	900	900	750	750							
300 kVA	CU	600	600	500	500							2 - 250 KCM
	AL	900	900	750	750							

208Y/120-VOLT THREE-PHASE COMPACT PADMOUNT TRANSFORMERS												
CPS Energy Compact Padmount Transformer	Maximum Allowable Number and Size in KCM of Conductors Per Phase that Customer May Install in the CPS Energy Padmount Transformer Shown by kVA Rating at Left-Most Column. Note: If These Values are Exceeded or if Customer's Design Requires Splitting of Load at Transformer, Customer Shall Furnish and Install an Approved Cable Tapbox.											Conductors Per Phase CPS Energy Will Install if a Tapbox is Required
208Y/120V 3-Phase	Wire Type	1	2	3	4	5	6	7	8	9	10	(-)
75 kVA	CU	500	500	250	4/0							1 - 350 KCM
	Al	750	750	350	250							
150 kVA	CU	500	500	250	4/0							2 - 350 KCM
	AL	750	750	350	250							
225 kVA	CU	600	600	500	500							3 - 350 KCM
	AL	900	900	750	750							
300 kVA	CU	600	600	500	500							3 - 500 KCM
	AL	900	900	750	750							

Note 1: Customer shall furnish and install approved cable lugs in their tap box to receive CPS Energy 90 degrees C. conductors from CPS Energy Transformer (Refer to Figure 1000.1).

Note 2: Customer shall submit tap box shop drawings to CPS Energy's Electric Service Standards Section for review and approval prior to installation.

Note 3: Tap box shall be installed in accordance with Section 1000 and serve as the point of delivery.

TABLE 1000.2
WIREWAY SIZES TO BE USED WITH TAP BOX INSTALLATIONS

Conductor Size	Number of Conductors Per Phase and Wireway Dimensions (in inches)									
	1	2	3	4	5	6	7	8	9	10
1/0 through 4/0	6 x 6	6 x 6	6 x 6							
250 KCM	6 x 6	6 x 6	6 x 6	8 x 8	8 x 8	10 x 8				
350 KCM	6 x 6	8 x 6	8 x 8	8 x 8	10 x 8	10 x 10	12 x 14	12 x 14		
500 KCM	6 x 6	8 x 8	10 x 8	10 x 10	10 x 12	10 x 12	14 x 14	14 x 14	14 x 16	14 x 16
750 KCM	8 x 6	10 x 8	12 x 12	10 x 14	12 x 14	14 x 14	14 x 16	14 x 18		

Notes:

1. Wireways are shown as (width x height) in inches.
2. Wireways shall be furnished by Customer and be installed by CPS Energy.
3. Customer shall be responsible for furnishing opening into tap box after coordinating with CPS Energy on exact location of wireway.
4. If a conductor size other than those listed herein are used, the wireway shall be sized based on the next size larger conductor shown.

TABLE 1000.3
SECONDARY CONDUITS FROM PADMOUNT TRANSFORMERS (STANDARD AND COMPACT)

STANDARD SIZE PADMOUNT TRANSFORMERS

Conductor Size	Maximum Number of Conduits	Maximum Conduit Size	Optional Quantity and Conduit Size
1/0 through 4/0	4	3-inch	N/A
250 KCM	6	3-inch	N/A
300 KCM	6	4-inch	N/A
350 KCM	8	4-inch	N/A
400 KCM	8	4-inch	N/A
500 KCM	10	4-inch	N/A
600 KCM	10	4-inch	N/A
700 KCM	10	4-inch	8 - 5 inch
750 KCM	10	4-inch	8 - 5 inch
800 KCM	10	4-inch	8 - 5 inch
900 KCM	10	4-inch	8 - 5 inch
1000 KCM	10	4-inch	8 - 5 inch

Note: Conduits shall only exit bottom of padmounted transformers; they are not allowed to exit tops or sides.

COMPACT SIZE PADMOUNT TRANSFORMERS

Conductor Size	Maximum Number of Conduits	Maximum Conduit Size	Optional Quantity and Conduit Size
350 KCM	4	4-inch	N/A
400 KCM	4	4-inch	N/A
500 KCM	4	4-inch	N/A

Note: Conduits shall only exit bottom of padmounted transformers; they are not allowed to exit tops or sides.

TABLE 1000.4
ALLOWABLE AMPACITIES OF INSULATED CONDUCTORS

Allowable Ampacities of Single-Insulated Conductors Rated Up to and Including 2000 Volts in Free Air, Based on Ambient Temperature of 30°C or 86°F							
Size	Temperature Rating of Conductor						Size
	60°C (140°F)	75°C (167°F)	90°C (194°F)	60°C (140°F)	75°C (167°F)	90°C (194°F)	
AWG or KCMIL	Types	Types	Types	Types	Types	Types	AWG or KCMIL
	TW UF	RHW, THHW THW, XHHW	RHH, THHN XHH, XHHW	TW UF	RHW, THHW THW, XHHW	RHH, THHN XHH, XHHW	
	Copper			Aluminum			
18	----	----	14	----	----	----	----
16	----	----	18	----	----	----	----
14	15	20	25	----	----	----	----
12	20	25	30	15	20	25	12
10	30	35	40	25	30	35	10
8	40	50	55	35	40	45	8
6	55	65	75	40	50	55	6
4	70	85	95	55	65	75	4
3	85	100	115	65	75	85	3
2	95	115	130	75	90	100	2
1	110	130	145	85	100	115	1
1/0	125	150	170	100	120	135	1/0
2/0	145	175	195	115	135	150	2/0
3/0	165	200	225	130	155	175	3/0
4/0	195	230	260	150	180	205	4/0
250	215	255	290	170	205	230	250
300	240	285	320	195	230	260	300
350	260	310	350	210	250	280	350
400	280	335	380	225	270	305	400
500	320	380	430	260	310	350	500
600	350	420	475	285	340	385	600
700	385	460	520	315	375	425	700
750	400	475	535	320	385	435	750
800	410	490	555	330	395	445	800
900	435	520	585	355	425	480	900
1000	455	545	615	375	445	500	1000
1250	495	590	665	405	485	545	1250
1500	525	625	705	435	520	585	1500
1750	545	650	735	455	545	615	1750
2000	555	665	750	470	560	630	2000

Note 1: Table 310.15 (B) (16) reprinted with permission from NFPA 70-2020, *National Electrical Code*®, Copyright 2019, National Fire Protection Association, Quincy, MA 02169.

Note 2: Refer to NEC for necessary derating of conductors as required based on ambient temperature and conduit fill. This reprinted material is for reference only and does not represent the complete or official position of the NFPA or CPS Energy.

FIGURE 1000.1
TYPICAL WEATHERPROOF CABLE TAP BOX /TRANSFORMER INSTALLATION

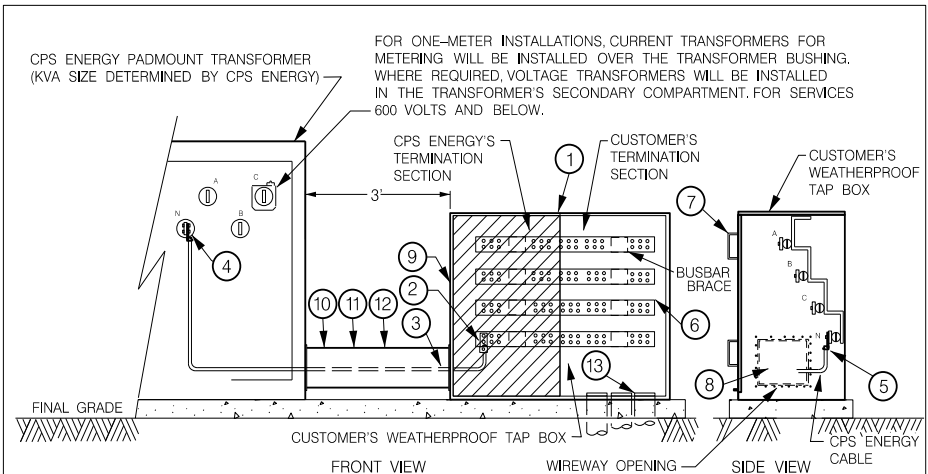

NOTES:

1. TAP BOX IS REQUIRED WHERE CUSTOMER'S LOAD CONDUCTORS ARE IN EXCESS OF THOSE ALLOWED IN TABLE 1000.1 (A) OR (B) OR WHEN CUSTOMER IS APPROVED BY CPS ENERGY TO INSTALL A SECOND WIREWAY LATERAL FOR SPLITTING LOAD OR OTHER CONDITIONS OUTLINED IN SECTION 200.
2. CPS ENERGY WILL EXTEND THE POINT OF DELIVERY (POD) TO TAP BOX LOCATED 3 FT FROM SECONDARY SIDE OF CPS ENERGY TRANSFORMER.
3. CPS ENERGY WILL FURNISH AND INSTALL COPPER CONDUCTORS FROM TRANSFORMER TO TAP BOX.
4. CPS ENERGY WILL FURNISH TERMINALS FOR CONNECTIONS AT TRANSFORMER AND MAKE ALL TERMINATIONS OF THESE CONDUCTORS IN TRANSFORMER.
5. CUSTOMER SHALL BE RESPONSIBLE FOR FURNISHING AND INSTALLING:
 - A. TAP BOX, 3-FT WIREWAY AND
 - B. ALL NECESSARY TERMINALS REQUIRED TO CONNECT CPS ENERGY AND CUSTOMER CONDUCTORS IN TAP BOX.
6. CPS ENERGY WILL MAKE TERMINATIONS OF CONDUCTORS FROM TRANSFORMER ONTO TAP BOX BUS BARS.
7. CUSTOMER SHALL FURNISH SINGLE-BARREL, TWO-HOLE TONGUE LUGS FOR TERMINATION OF ALL CONDUCTORS ONTO BUS IN TAP BOX. MOUNTING HOLES IN TONGUE TO BE 9/16 INCHES AND VERTICALLY SPACED 1 3/4 INCHES APART. CABLE LUG WIDTH SHALL NOT EXCEED 1 3/4 INCHES AND HEIGHT SHALL NOT EXCEED 2 1/4 INCHES. EACH LUG USED SHALL BE PLATED TO INDUSTRY STANDARDS AND SHALL BE A TYPE APPROVED FOR THE CONDUCTORS AND FOR CONNECTION TO THE BUS BARS. WHEN ALL COMPONENTS ARE ALUMINUM (BUS AND LUGS), ONLY ALUMINUM BOLTS AND WASHERS SHOULD BE USED.
8. CPS ENERGY SHALL DESIGNATE LOCATION AND PROVIDE OPENING FOR WIREWAY AT TRANSFORMER SECONDARY.
9. TAP BOX MUST BE PRE-APPROVED BY CPS ENERGY'S ELECTRIC SERVICE AND METERING STANDARDS SECTION AND MUST MEET THE FOLLOWING DESIGN PROVISIONS AND CONSTRUCTION SPECIFICATIONS:
 - A. TAP BOX MUST BE PROVIDED WITH STEPPED BUS DESIGN
 - B. CUSTOMER MUST DESIGNATE SPACE CLOSEST TO WIREWAY SOLELY FOR TERMINATION OF CPS ENERGY CONDUCTORS
 - C. TAP BOX MUST BE EQUIPPED WITH PADLOCK HASPS FOR CPS ENERGY LOCKS AND TWO EACH PENTABOLT LOCKING DEVICES LOCATED AT TOP AND BOTTOM OF DOOR ASSEMBLY.
 - D. TAP BOX SHALL BE PERMANENTLY AND LEGIBLY MARKED WITH THE VOLTAGE AND CURRENT RATING AND WITH MANUFACTURER'S NAME OR TRADEMARK IN SUCH A MANNER TO WITHSTAND THE CONDITIONS. SUCH MARKING SHALL BE LOCATED INSIDE ON THE LEFT-SIDE PANEL NEAR THE FRONT OF TAP BOX.
 - E. CUSTOMER SHALL SIZE TAP BOX TO ACCOMMODATE ALL CONDUCTORS THAT WILL BE INSTALLED.
 - F. TAP BOX ENCLOSURE SHALL BE SUITABLE FOR THE CONDITIONS AND CONSTRUCTED OF MINIMUM 12 GAUGE CORROSION RESISTANT STEEL, PRIMED AND PAINTED.
 - G. TAP BOX SHALL BE EFFECTIVELY BONDED BY CUSTOMER IN ACCORDANCE WITH THE NEC.
 - H. TAP BOX SHALL BE INSTALLED ON CONCRETE SLAB THAT IS MONOLITHICALLY POURED WITH CPS ENERGY'S TRANSFORMER SLAB.
 - I. TAP BOX SHALL BE EQUIPPED WITH CONTINUOUS HINGE-COVER DOUBLE DOORS WITH STAINLESS STEEL HINGE PIN. DOOR SHALL BE SECURED BY A THREE-POINT LOCKING MECHANISM AND A T-HANDLE WITH PROVISIONS FOR PADLOCKS.
10. WIREWAY SHALL BE FURNISHED BY CUSTOMER AND BE INSTALLED 3 INCHES ABOVE THE TRANSFORMER SLAB.
11. WIREWAY SHALL NOT CONTAIN REMOVABLE COVERS AND SHALL BE EQUIPPED WITH GASKETED FLANGES AND BE ON THE SIDE PANEL OF THE TRANSFORMER'S SECONDARY COMPARTMENT.
12. WIREWAY SHALL BE CONSTRUCTED OF CORROSION RESISTANT STEEL, PRIMED AND PAINTED. WIREWAY MUST BE REMOVABLE TO ALLOW FOR TRANSFORMER REPLACEMENT.
13. CUSTOMER SERVICE ENTRANCE LATERAL TO EXIT ON THE DESIGNATED CUSTOMER SIDE OF TAP BOX.

FIGURE 1000.2

TYPICAL COMMERCIAL PADMOUNT TRANSFORMER INSTALLATION WITH TAP BOX

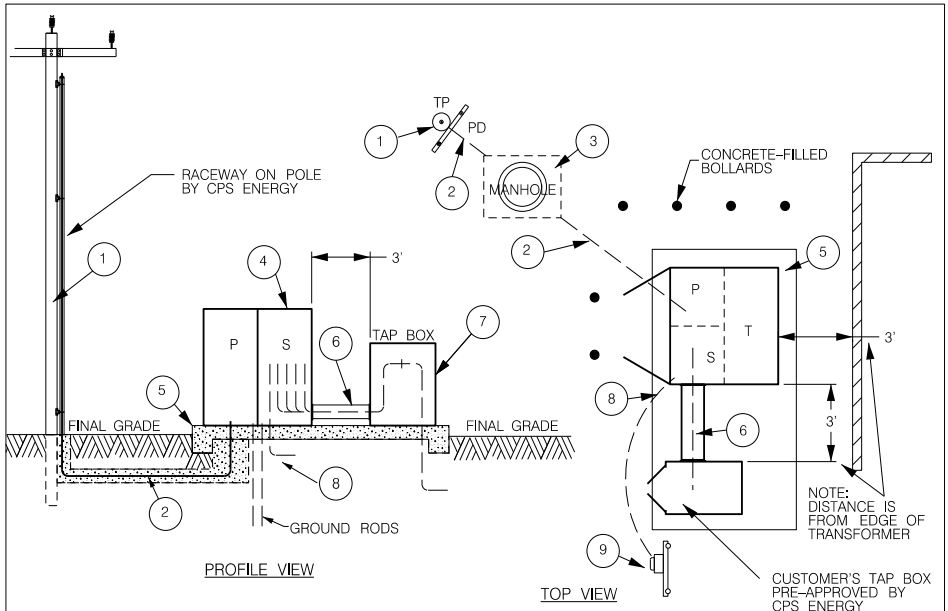

NOTES:

1. CPS ENERGY TERMINAL POLE (TP) ON CUSTOMER'S PREMISES FOR OVERHEAD TO UNDERGROUND LINE TRANSITION. LOCATION DETERMINED BY AVAILABILITY OF CPS ENERGY DISTRIBUTION LINES.
2. PRIMARY DUCTLINE (PD) FROM (TP) TO TRANSFORMER (T). CUSTOMER INSTALLS DUCTLINE FROM TRANSFORMER THROUGH ELBOWS ON TP. DUCTLINE TO BE ENCASED WITH THREE INCHES OF CONCRETE. CONCRETE RISES TO SLAB AND FINISHED GRADE TO TOTALLY ENCASE ELBOWS. DUCTLINE CONSISTS OF TWO FOUR-INCH SCHEDULE 40, 90°C PVC, EXCEPT ELBOWS AT (TP) TO BE SCHEDULE 80. IN ALL CASES CPS ENERGY FURNISHES AND INSTALLS RACEWAY ON (TP).
3. MANHOLES ARE REQUIRED FOR LONG DUCTLINES. CUSTOMER INSTALLS MANHOLES IN ACCORDANCE WITH CPS ENERGY SPECIFICATIONS. DUCTS MUST DRAIN TO MANHOLES.
4. TRANSFORMER (T) TO BE IN ACCEPTABLE LOCATION FURNISHED BY CUSTOMER. THERE SHALL BE ADEQUATE VERTICAL AND HORIZONTAL ACCESS. ITS DOORS SHALL OPEN AWAY FROM BUILDING AND A MINIMUM OF SIX FEET OF CLEAR SPACE SHALL BE IN FRONT OF DOORS AND THREE-FOOT CLEARANCE ON EACH SIDE AND REAR OF TRANSFORMER. CUSTOMER TO INSTALL BOLLARD PROTECTION AS NECESSARY.
5. STEEL-REINFORCED CONCRETE SLAB BUILT BY CPS ENERGY OR CUSTOMER TO CPS ENERGY SPECIFICATIONS. CUSTOMER SHALL FURNISH AND INSTALL TWO EACH 58-INCH BY 8-FOOT GROUND RODS AT TRANSFORMER PAD FOR CONNECTION BY CPS ENERGY.
6. SERVICE LATERAL WITH APPROVED CONNECTORS AND WIREWAYS OR CONDUIT FURNISHED AND INSTALLED BY CUSTOMER. CPS ENERGY LIMITS SIZE OF CABLE AND WIREWAY IN SECONDARY COMPARTMENT (S). CPS ENERGY MAKES ALL CABLE CONNECTIONS WITHIN THE TRANSFORMER, (REFER TO TABLES 1000.1, 1000.2 AND 1000.3).
7. IF CUSTOMER'S CONDUCTORS EXCEED THOSE ALLOWED BY CPS ENERGY OR WHEN CUSTOMER DESIGN REQUIRES SPLITTING OF LOAD AT THE TRANSFORMER THEN CUSTOMER SHALL FURNISH AND INSTALL AN APPROVED CABLE TAP-BOX (TB) THREE FEET FROM THE TRANSFORMER. TAP BOX SHALL BE POSITIONED TO FACE THE SAME DIRECTION AS TRANSFORMER (REFER TO FIGURE 1000.1 FOR TAP BOX INSTALLATION PROVISIONS).
8. BUILDER OF SLAB TO FURNISH AND INSTALL ONE 2-INCH SCHEDULE 40 OR 80 PVC METER CONDUIT FROM SECONDARY COMPARTMENT (S) OF TRANSFORMER TO THE METER LOCATION, OR TO A POINT 2 FEET OUT FROM TRANSFORMER SLAB WHERE METERING EQUIPMENT IS NOT INSTALLED AT SECONDARY OF TRANSFORMER.
9. METER SOCKET FURNISHED BY CPS ENERGY FOR INSTALLATION BY CUSTOMER. SOCKET MAY BE ON THE BUILDING OR ON A METER RACK AT EDGE OF SLAB, AND NO FURTHER THAN 20 FEET FROM TRANSFORMER. METERING EQUIPMENT SHALL NOT BE ON THE TRANSFORMER ENCLOSURE. REFER TO FIGURE 1800.18 FOR METERING EQUIPMENT RACK SPECIFICATIONS.
10. CPS ENERGY WILL ISSUE A CONSTRUCTION SKETCH FOR ALL COMMERCIAL PADMOUNT TRANSFORMER INSTALLATIONS. ALL SLAB AND DUCTLINE WORK DONE BY CUSTOMER MUST BE INSPECTED BY CPS ENERGY BEFORE CONCRETE IS POURED OR BACKFILLING IS DONE. CUSTOMER MUST REQUEST INSPECTIONS 24 HOURS IN ADVANCE.

SECTION 1100

SERVICE FROM DOWNTOWN NETWORK SYSTEM



1101 General:

CPS Energy provides electric service to the majority of the San Antonio Central Business District from its Downtown Network System. This system is totally underground and consists of a highly reliable redundant circuit design with a paralleled secondary grid. There are two types of services provided to Customers in the Downtown Network System: Secondary Grid service and Transformer Vault/Room service. Customer shall contact the CPS Energy Customer Service Representative for the geographical boundaries of the Downtown Network System and for proper coordination when service is requested from the Downtown Network System.

1102 Secondary Grid Service:

Customers with demand loads less than or equal to 300 kVA and with a three-phase, four-wire service voltage of 208Y/120-volt will be served from the secondary grid of the Downtown Network System. Customers with demand loads greater than 300 kVA or with a service voltage of three-phase, four-wire, 480Y/277-volt will be required to install a transformer vault or room on or adjacent to Customer's premise (Refer to Article 1103).

Where CPS Energy is unable to supply Customer's demand load due to limited load serving capability from its network grid system, CPS Energy shall either (1) upgrade the secondary grid system or (2) construct a transformer vault adjacent to Customer's premises at CPS Energy's expense and in accordance with Article 1103.1.

1102.1 Service Lateral Conduits from Manhole or Vault:

Customer shall be responsible for furnishing and installing the service lateral conduits in accordance with CPS Energy's specifications from a manhole or vault to Customer's premises. Service conduits shall terminate immediately upon entering Customer's building to grid-tied disconnect as specified in Article 1102.2 and in no case extend greater than 4 feet into the building's electrical room. CPS Energy shall directly supervise all work involving penetrations into CPS Energy manholes or vaults. Customer shall coordinate with CPS Energy for all such penetrations.

Note 1: *Conduits shall be concrete encased Schedule 40 or 80 PVC with all elbows being long radius type.*

1102.2 Service Lateral Conductors from Manhole or Vault:

CPS Energy shall furnish and install the service lateral conductors and make necessary terminations. CPS Energy will terminate its service lateral conductors at Customer's premises to a grid-tied disconnect as described below:

(A) Grid-Tied Disconnect:

The grid-tied disconnect shall be furnished and installed by Customer and be located at Customer's premises as described in Article 1102.1. The grid-tied disconnect shall be rated for the available fault current as determined by CPS Energy's Network Engineering Section at time of design and be equipped with fuses not larger than 800 amps. Customer shall also be responsible for furnishing 3 spare fuses that are to be left in disconnect (Refer to Definition of "Grid-Tied Disconnect").

Note: *Grid-tied disconnects serve as the point of delivery and are intended to protect CPS Energy equipment. They shall not be used as service equipment by Customer. Customer shall be responsible for installing service disconnecting means in accordance with the NEC and other applicable codes (Refer to Article 1102.6 and Definition of "Point of Delivery").*

1102.3 Locking and Sealing:

The grid-tied disconnect shall be lockable and sealable by CPS Energy and be readily accessible to CPS Energy personnel for maintenance and/or emergency conditions.

1102.4 Load-Side Raceways from Grid-Tied Disconnect:

Customer shall furnish and install load-side raceways to Customer's service equipment. Load-side raceways installed ahead of CPS Energy metering equipment shall be rigid metal conduit (RMC), intermediate metal conduit (IMC), or bus duct. All raceways shall be continuous except for couplings and if utilized, bus duct shall be of the non-ventilated type.

1102.5 Load-Side Conductors from Grid-Tied Disconnect:

Customer shall furnish and install load-side conductors to Customer's service equipment. Customer must accept four-wire wye service at their service disconnecting means and assure that all single-phase loads are properly balanced. Paralleled conductors must be electrically joined at both ends to form a single conductor.

Note: *Customer shall furnish necessary terminals for connection to CPS Energy grid-tied disconnects. CPS Energy will make connections to line-side of grid-tied disconnects.*

1102.6 Customer Service Equipment:

Customer service disconnecting means shall be provided with an overcurrent device that shall be an integral part of the service disconnecting means and/or shall be located immediately adjacent thereto. In addition, the Customer service disconnecting means shall be installed in accordance with (A) through (C) below:

(A) Fault Current Rating:

The Customer owned service disconnecting means shall be rated for the available fault current as determined by CPS Energy's Network Engineering Section at time of design and shall be installed in accordance with the NEC and all applicable codes (Refer to Section 400).

Note: *Customer shall design service with consideration for future fluctuations in fault current that may result from Customer loads changing on the Downtown Network System. Upon request, CPS Energy will make available fault current information.*

(B) Location:

The Customer service disconnecting means shall be co-located at a readily accessible location nearest the grid-tied disconnect. In no case shall the Customer's service disconnecting means be located in a different room or area from the grid-tied disconnect which serve as the point of delivery.

(C) Frequent Switching:

Customer shall design their installation in a manner that will prevent CPS Energy metering equipment from being switched off frequently or switched off for any extended periods of time.

Note: Designs incorporating load-side disconnect(s) after CPS Energy metering equipment to accommodate loads that will be switched off frequently or switched off for an extended period of time will help limit damage to sensitive metering equipment and protect against unnecessary down time for Customers.

1103 Transformer Vault/Room Service:

For Customer demand loads greater than 300 kVA, or where a service voltage of three-phase, four-wire wye 480Y/277-volt is required, Customer shall construct a transformer vault on or immediately adjacent to their premises (Refer to Definition of "Transformer Vault").

Where space is not available for a Customer built transformer vault on or immediately adjacent to Customers premises, Customer shall be responsible for constructing a transformer room on their premises (Refer to Definition of "Transformer Room").

Note: Customer shall build transformer vault or room in accordance with the National Electric Code (NEC) and CPS Energy specifications and be responsible for coordinating all inspections required by CPS Energy (Refer to Article 1103.1 and 1103.1 (J)). Customer shall be responsible for all costs associated with constructing the transformer vault or room.

1103.1 Customer Built Transformer Vaults or Rooms:

The Customer's load requirements will determine the transformer vault or room size (typical four transformer vault size is 32 feet (L) x 15 feet (W) x 12 feet (H) and 38 feet (L) x 20 feet (W) x 12 feet (H)) for service voltages 208Y/120-volt and 480Y/277-volt respectively. Customer shall provide sealed engineered drawings of the proposed vault or room per CPS Energy requirements. Prefabricated vault designs will be considered and approved by CPS Energy on case by case bases. CPS Energy will install all infrastructures which shall include transformer(s), network protectors, primary conductors, and all associated circuitry inside the transformer vault or room as required.

Complying with CPS Energy specifications does not relieve the Customer from complying with other applicable codes and regulations such as COSA ordinances (historic preservation office, environmental, etc.), permits, utility-locates, state regulations, and/or other industry standards. Where Customer builds a transformer vault or room as required by CPS Energy, it shall conform to the general and specific requirements as follows:

(A) Location:

Customer shall use a suitable location on or immediately adjacent to their premises for the Customer built transformer vault. Areas such as public right-of-way immediately adjacent to Customer's premises are preferred locations for transformer vaults. Customer shall coordinate with the CPS Energy Customer Service Representative to verify that Customer owned secondary service conductors (lateral) from transformer vault will not be routed in public right-of-way.

Where space is not available on or immediately adjacent to Customer's premises, then Customer shall construct a transformer room within their premises. Construction of transformer room shall be coordinated, inspected, and approved by CPS Energy's Network Engineering Section. CPS Energy will not construct transformer vaults or rooms on or within Customer's premises.

(B) Easements:

Customer shall grant or provide CPS Energy with necessary easements for transformer vaults or rooms and associated electric lines and equipment. Customer shall coordinate with the CPS Energy Customer Service Representative for specific details and for conditions of use of such easements.

(C) Accessibility:

The design of a transformer vault or room shall ensure full 24-hour immediate access and allow close approach (be within 8 feet of a hard driving surface). In addition, the design shall meet accessibility requirements listed below:

- (1) Maintain a clear access route for delivery and installation of CPS Energy equipment.
- (2) There shall be a 73-inch x 97-inch slab at an outside entrance (ground level) to receive transformers weighing up to 20,000 pounds each.
- (3) Entrance is to be readily accessible and not be blocked vertically 50 feet or horizontally 12 feet in front and both sides of slab opening for crane operations (no exceptions).

(D) Basic Design Criteria:

All transformer vault or room designs, and locations shall be coordinated and approved by the CPS Energy Downtown Network Engineering Section and shall incorporate the following basic design requirements:

- (1) Transformer vault or room shall "not be used for storage" of any kind. Vault and/or room shall be considered property of CPS Energy and be used for CPS Energy equipment only.
- (2) No Customer pipes, ducting, or wiring (except Customer's service conductors) shall enter or pass through the transformer vault or room.
- (3) No other utilities such as gas, water, sewer, communication cables or Customer systems of any kind shall be allowed to enter or pass through the transformer vault or room.
- (4) Where buildings are designed with overhangs or similar type of roof coverings that extend over CPS Energy's transformer vault or room and are determined by CPS Energy to interfere with the installation or removal of CPS Energy equipment, such overhangs and roofs shall be provided with removable hatches or roof covers as approved by CPS Energy.

Note: *In addition to these basic design requirements, the Customer built transformer vault or room shall meet the specific design requirements listed in (E) through (K) below:*

(E) Walls, Roof and Floor:

- (1) Walls and roof shall be constructed of materials that have adequate structural strength for the conditions, with a minimum fire resistance of 3-hours. A 12-inch thick reinforced concrete is a standard requirement on a pour in place design. In cases where 8-inch CMU is approved, it shall be filled with 2500 psi concrete with reinforced rebar. The roof must meet the requirement of the H-20, highway loading specification. Customer shall pour concrete in a manner that will eliminate air voids. No existing clay tiles, sheetrock or stucco wall of any type shall be used as interior vault walls.

Note: Where constructing a transformer room within an existing building, CPS Energy will require a structural engineer's sealed letter attesting that the construction of such walls and roof are adequate for the conditions and the imposed equipment weight to be supported.

- (2) The floors of transformer vaults or rooms in contact with the earth shall be of reinforced concrete design to support CPS Energy transformers with a point load of up to 20,000 Lbs. each. Based on the Customer's load, a standard CPS Energy transformer vault or room can normally accommodate up to four transformers. Floors shall have a smooth finish to allow for steel rolling rods to move freely.

Note: Where constructing a transformer room within an existing building, CPS Energy will require structural engineer sealed letter attesting that the construction of such floors is adequate for the conditions and the imposed equipment weight to be supported.

- (3) Where required for installation and removal of transformers, transformer vault or room ceilings shall have removable, weatherproof slabs; sizes to be specified by CPS Energy. There shall be a 73-inch x 97-inch minimum slab or as specified by CPS Energy and it shall be installed by Customer as part of the transformer vault or room construction and completion.
- (4) Transformer vault or room ceilings shall have a 30-inch diameter personnel entrance where required for outside access by CPS Energy authorized personnel. The ceiling shall also accommodate concrete inserts as specified by the CPS Energy Customer Service Representative for support of secondary bus.
- (5) Transformer vault or room penetration of secondary grid or service lateral conductors shall be a minimum height of 42 inches and a maximum height of 60 inches from the floor level inside of the transformer vault or room. Customer shall coordinate with the CPS Energy Customer Service Representative on exact location and methods of penetration of secondary grid or service lateral conductors. Final design shall be submitted to CPS Energy for approval.

(F) Drainage:

Customer shall provide a sump hole with 1/2-inch thick metal galvanized cover with drainage holes where water or other liquids would need to be pumped from transformer vault or room.

- (1) The sump hole shall have minimum dimensions of 12 x 12 x 24 inches deep or 12 inches in diameter and 24 inches deep (24-inch depth includes 12-inch floor thickness and 12-inch sump hole).
- (2) The transformer vault or room floor shall be pitched toward the sump hole with a 1-inch slope.
- (3) The sump hole shall be located directly below personnel entrances unless otherwise specified by CPS Energy.
- (4) The transformer vault or room design shall be such that it does not allow intrusion of water through walls, floors, ceilings, joints, and all penetrations. In some cases, waterproofing may need to be applied. All sealant used inside the transformer vault or room shall be UL approved.
- (5) A separate 2-inch pipe to city storm drainage system will be required. Customer shall coordinate with the CPS Energy Customer Service Representative.

(G) Ventilation:

Fan forced natural air cross ventilation shall be provided.

- (1) The transformer vault or room shall be vented directly to an outdoor area. The transformer vault or room ventilation shall not be mixed with the building ventilation or cooling system.
- (2) Ventilation consisting of two each 24-inch diameter ventilators must be provided. Lower ventilator shall be 12 inches above floor. Upper ventilator shall exhaust to outside air and be 12 inches below ceiling or as otherwise approved by CPS Energy.
- (3) CPS Energy will furnish and install ventilating fans and associated circuitry.
- (4) Ventilation openings shall be installed as far away as possible from doors, windows, fire escapes, and combustible materials. No ventilation openings to the interior of building are allowed. Openings outside the transformer vault or room shall be located above water level and not in the street, driveways, or parking lots.
- (5) Ventilation openings shall be covered with durable gratings, heavy gauge screens or louvers, according to the treatment required in order to avoid unsafe conditions. Gratings, etc. used to cover the openings shall be in accordance with CPS Energy specifications and shall be furnished and installed by Customer.
- (6) Ventilation ducts shall be constructed of heavy gauge corrugated steel or concrete and all joints shall be watertight.
- (7) Ventilation in doors will not be accepted by CPS Energy.

(H) Doorways:

If the design includes a doorway then the Customer shall provide doorways as specified by CPS Energy's Network Engineering Section.

- (1) A minimum of two 4-foot (W) x 9-foot (H) side by side doors leading into a transformer room from the building exterior shall be provided. Doors shall be designed to swing out 180 degrees with no external obstructions and be tight-fitting metal fireproof doors having a minimum 3-hour rating. CPS Energy will install a continuous 6-inch removable brick sill.
- (2) Entrance doors shall be equipped with locks, and fire doors shall be kept locked with access being allowed only to CPS Energy personnel. Locks and latches shall be arranged so that the door can be readily and quickly opened from the inside by a panic bar, pressure plate or other devices that are normally latched but open under simple pressure, per NEC. The second door must be fitted with surface bolts inside at top and bottom. Customer shall install one of the following as approved by CPS Energy: hasps for CPS Energy padlocks, cylinder locks keyed by a locksmith to CPS Energy keys or key pad lock combination mechanism. Only CPS Energy personnel shall have access and keys to doors.
- (3) Doors shall not be blocked by Customer equipment. The transformer vault or room shall be readily accessible through doorways at all times (24 hours).
- (4) CPS Energy shall label "Danger High Voltage" on the outside of the fire doors.

(I) Lighting:

Transformer vaults or rooms shall be electrically lighted. CPS Energy will install lighting and associated circuitry. Customer circuitry shall not be used.

(J) Inspection:

A series of critical inspections will occur during construction of the Customer built transformer vault or room to verify that it is constructed in accordance with CPS Energy specifications. Customer shall request a CPS Energy inspection a minimum of two days prior to each inspection. To schedule an inspection, Customer may contact the CPS Energy Customer Service Representative or refer to "Helpful Numbers" listed on the inside front cover page.

Note 1: *Before concrete is poured the following inspections for transformer vaults or rooms are required:*

- | | | |
|-------------|--|----------------------|
| (1) Ceiling | (4) Doors | (7) Vent Grates |
| (2) Floors | (5) Slab Opening | (8) Duct Bank Trench |
| (3) Walls | (6) Vent-Pipe and Connect
to Transformer Vault
or Room Vault | (9) Final Inspection |

Note 2: *Where Customer constructs transformer vaults or rooms and does not call for required CPS Energy inspections, CPS Energy reserves the right to require Customer to remove all or part of the concrete and/or to not approve the transformer vault or room design.*

(K) Fire Ratings:

The building design or the authority having jurisdiction (AHJ) may require fire protection for the Customer's equipment outside of transformer vault or room. CPS Energy assumes no responsibility for the operation of this system.

- (1) All walls, floors, and ceilings shall have a minimum 3-hour fire rating. All doors shall also have a 3-hour fire rating. All penetrations (floor, wall, and ceiling) including the doors shall be sealed by Customer in accordance with applicable NFPA codes.
- (2) All sealant used inside the transformer vault or room shall be UL approved and have the appropriate fire rating for the enclosure.
- (3) Dampers shall have a 3-hour fire rating.
- (4) Sprinkler systems or other fire protection devices shall not be installed in transformer vaults or rooms.

1103.2 Fuse Pads in Transformer Vaults and/or Rooms:

Customer's service shall be supplied and accepted from CPS Energy fuse pad located within the Customer built transformer vault or room. Not more than one service shall be supplied from a fuse pad. The fuse pad shall be the point of delivery and be furnished and installed by CPS Energy. Customer's service equipment location shall be as close to the transformer vault or room as possible. (Refer to Definition of "Fuse Pad")

Note: *Details concerning fuse pads are as follows:*

- (1) To ensure proper phasing and connecting of conductors, the exact location of Customer and CPS Energy facilities must be closely coordinated with the CPS Energy Customer Service Representative.
- (2) The location for fuse pads shall be on the transformer vault or room wall as specified by CPS Energy.
- (3) Customer shall advise CPS Energy of bus bar width or cable size and quantity to connect to fuse pads plus any other details related to connections on fuse pads. CPS Energy will not allow bus bars having a width less than 4 inches to be connected on its fuse pads.
- (4) Customer shall furnish all conductors and CPS Energy approved connectors and copper flags (if required) on load-side of fuse pads. Service-entrance shall be copper buss or copper conductors. Where service-entrance conductors are installed, Customer shall furnish single-barrel, two-hole tongue lugs. Mounting holes in tongue shall be 9/16 inches and spaced vertically and horizontally 1 3/4 inches center to center. Cable lug width shall not exceed 1 3/4 inches and height shall not exceed 2 1/4 inches.
- (5) Where required, Customer shall furnish pre-drilled bus bars and copper flags for fuse pad connections. The connection surfaces of bus bars and cable connections must have appropriate plating for corrosion protection. CPS Energy will make all connections on fuse pads.

- (6) Bus bars to fuse pads must be insulated beyond fuse pad panels.
- (7) Low impedance bus bars and Customer's conductors must be unscrambled (all like phases to come together). Customer shall provide a descrambling area (box) sized to the NEC and meeting CPS Energy specifications prior to entering transformer vault or room or other CPS Energy facilities. The descrambling box shall be provided with a pentabolt device and means to lock and seal by CPS Energy (Refer to Article 1103.4).
- (8) The opening and sealing of penetrations into transformer vaults or rooms for Customer's conductors shall be closely coordinated with the CPS Energy Customer Service Representative. This work shall be done by Customer and must be watertight and not permit rodent penetration. All sealant used inside the transformer vault or room shall be UL approved and sealed per NFPA codes with the appropriate fire rating.

1103.3 Service Lateral Raceways and Conductors:

All Customer owned raceways and conductors installed on the load-side of the point of delivery, shall be furnished, installed, and maintained by Customer and be in accordance with (A) and (B) below:

(A) Service Lateral Raceways:

Customer shall furnish and install raceways from the fuse pad location or descrambling box at Customer built transformer vault or room to Customer's service equipment. Such raceways shall extend not more than 4 feet inside the building. For greater distances, Customer must obtain approval from CPS Energy and install raceways in a manner that will render them as being outside of the building (Refer to Definition of "Conductors Considered Outside of Building").

Service lateral raceways installed ahead of CPS Energy metering equipment shall be rigid metal conduit (RMC), intermediate metal conduit (IMC), or bus duct. All raceways shall be continuous except for couplings and if utilized, bus duct shall be of the non-ventilated type.

Exception: *Where raceways are installed underground from a fuse pad or descrambling box at Customer built transformer vault or room to Customer's service equipment, they may be scheduled 40 or 80 PVC where installed in a manner rendering them outside of building (Refer to Definition of "Conductors Considered Outside of Building").*

(B) Service Lateral Conductors:

Customer will be responsible for furnishing and installing service lateral conductors from the Customer built transformer vault or room to Customer's service equipment. Customer must accept four-wire wye service at their service disconnecting means and assure that all single-phase loads are properly balanced. The service lateral conductors shall be installed in accordance with the NEC and all applicable codes. Paralleled conductors must be electrically joined at both ends to form a single conductor.

Note: *Customer shall coordinate with the CPS Energy Customer Service Representative for approved methods and location of descrambling box and for penetration into transformer vault or room and fuse pad.*

1103.4 Descrambling Box:

Before entering transformer vault or room and fuse pad location, low impedance bus bars and Customer's conductors must be unscrambled (all like phases to come together). Customer shall provide a descrambling area (box) prior to entering transformer vault or room. The descrambling box shall be sized in accordance with the minimum provisions of the NEC and shall also meet the provisions of (1) through (4) below:

- (1) Be provided with a pentabolt device and sealing and locking means by CPS Energy.
- (2) Box shall be located immediately before entering the transformer vault or room.
- (3) Conduits used to penetrate transformer vault or room shall be scheduled 40 or 80 PVC with bell ends.
- (4) Sealing shall be provided by Customer in accordance with Article 1103.2

Exception: *Where location of transformer vault/room does not permit for the descrambling box to be located at a readily accessible location immediately on the outside of vault/room wall, the descrambling box may be incorporated into the vault with a pour in place design. The size of descrambling area shall be determined based upon the number and size of service conduits and CPS Energy's Network Section shall designate the approved location (Refer Figure 1100.3).*

1103.5 Customer Owned Service Disconnecting Means:

Customer owned service disconnecting means shall be provided with an overcurrent device that shall be an integral part of the service disconnecting means and/or shall be located immediately adjacent thereto. In addition, the Customer service disconnecting means shall meet the provisions outlined in (A) and (B) below:

(A) Fault Current Rating:

Customer owned service disconnecting means shall be rated for the available fault current as determined by the CPS Energy Customer Service Representative at time of design and shall be installed in accordance with the NEC and all applicable codes (Refer to Section 400).

Customer shall design service with consideration for future fluctuations in fault current that may result from Customer loads changing on the Downtown Network System. Upon request, CPS Energy will make available fault current information.

(B) Location:

Customer owned service disconnecting means shall be located on Customer's premises at a point nearest to the Customer built transformer vault or room and CPS Energy fuse pad.

1103.6 Point of Delivery:

The point of delivery shall be at the load side of the fuse pad located in Customer built transformer vault or room. Customer shall furnish all

necessary connectors or terminals and CPS Energy will make all connections to fuse pad.

1104 Services Located Outside a Building:

Where Customer meter loops are approved by CPS Energy to be located outside on a building wall, all metering and service equipment shall conform to standard heights and clearances. Free standing meter loops shall be housed in or on a specially designed enclosure or pedestal furnished and installed by Customer. These special enclosures and pedestals are for aesthetic purposes only. The special meter enclosure heights may vary from 3 feet to 6 feet in height. Drawings of such installations shall be provided to the CPS Energy Customer Service Representative for approval. Where the meter and Customer owned service equipment are located inside of a specially designed enclosure, the enclosure shall not be considered part of the meter loop for code purposes and all wiring and conduit shall be installed as if it were not in the enclosure (Refer to Figure 1100.1).

1105 Metering:

CPS Energy metering equipment shall be located immediately adjacent to Customer's service equipment on Customer's premises. Where instrument transformer rated metering equipment is required, then CPS Energy will furnish instrument transformers and standard enclosures, which shall be installed by Customer. Where Customer's service-entrance conductors exceed the maximum allowable conductors permitted within CPS Energy furnished metering enclosure, Customer shall furnish a pre-approved metering enclosure. Customer may also be permitted to install metering instrument transformers in pre-approved, metering compartment within Customer owned switchgear. (Refer to Section 1800)

Note: *Metering equipment shall not be located within a transformer vault or room.*

1105.1 Coordination of Metering Design with CPS Energy:

Customer shall coordinate with the CPS Energy Customer Service Representative for the review of the metering design by CPS Energy's Electric Service and Metering Standards Section prior to ordering any equipment including service equipment to verify metering design will conform to specifications and standards approved by CPS Energy. The following are some basic designs that are allowed by CPS Energy:

(A) Multiple Meters:

Where multiple meters are to be supplied by a 208Y/120-volt service and individual tenants do not require three-phase service, then 120/208-volt three-wire meters may be permitted by CPS Energy provided that metered loads can be balanced on the three-phase system. Each case must be approved by CPS Energy (Refer to Figure 1800.5).

(B) Modular Metering:

In some instances involving residential type loads, modular metering that meets CPS Energy specifications may also be permitted. Each case must be approved by CPS Energy. Modular metering is not allowed to supply commercial type loads (Refer to Figure 1800.14).

(C) Dedicated Metering Compartment in Customer Switchgear:

When CT's or VT's are required for the design proposed, CPS Energy may permit and/or require Customer to coordinate with manufacturer to provide a dedicated vertical compartment within Customer's switchgear to house such equipment. Such compartments shall be designed to meet CPS Energy specifications (Refer to Section 1800).

***Note:** Customer shall coordinate with the CPS Energy Customer Service Representative prior to ordering switchgear and/or other service equipment to verify metering design will conform to specifications and standards approved by CPS Energy.*

***Note:** Designs incorporating load-side disconnect(s) after CPS Energy metering equipment to accommodate loads that will be switched off frequently or switched off for an extended period of time will help limit damage to sensitive metering equipment and unnecessary down time for Customers.*

FIGURE 1100.1

TYPICAL DOWNTOWN NETWORK SYSTEM SERVICE WITH CPS ENERGY GRID-TIED DISCONNECT ABOVE GROUND

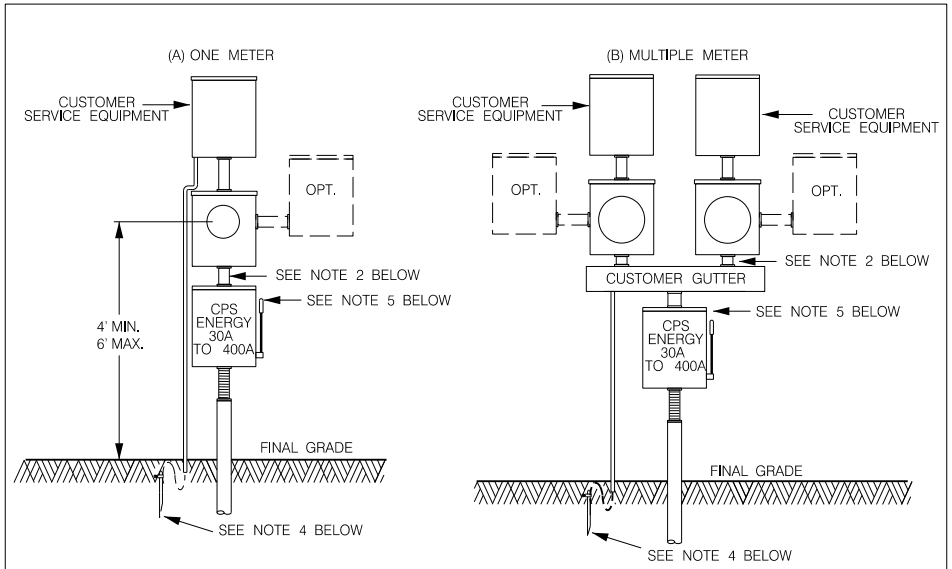

TYPICAL FREE STANDING DOWNTOWN NETWORK SYSTEM SERVICE (METER LOOPS)

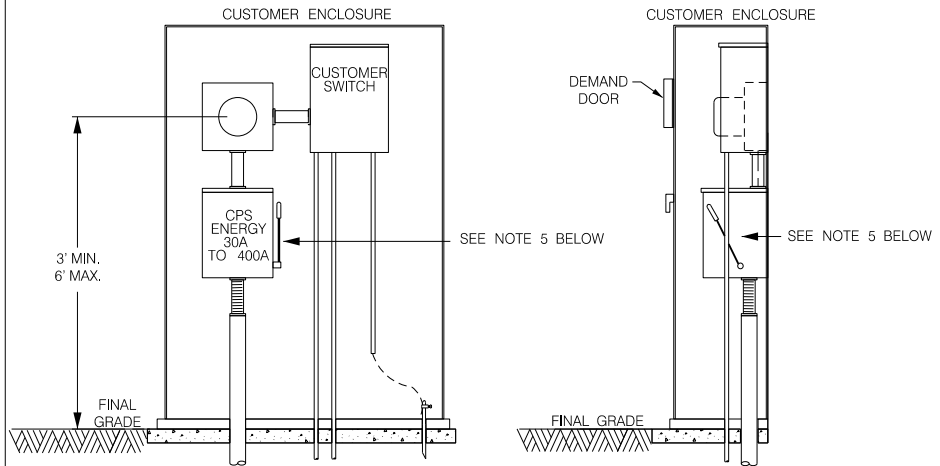

NOTES:

1. CUSTOMER ENCLOSURE TO BE PRE-APPROVED BY CPS ENERGY.
2. ALL CONDUIT NIPPLES SHALL BE METAL.
3. SERVICE OUTLET SHALL BE FURNISHED AND INSTALLED BY CUSTOMER. RACEWAY MAY BE EMT, RMC OR IMC.
4. MINIMUM 5/8-INCH X 8-FOOT GROUND ROD FURNISHED AND INSTALLED BY CUSTOMER IS REQUIRED BY CPS ENERGY AT ALL CUSTOMER SERVICE LOCATIONS. GROUNDING ELECTRODE SYSTEM MAY ALSO INCLUDE OTHER ELECTRODES AS REQUIRED BY THE NEC AND OTHER APPLICABLE CODES (REFER TO SECTION 1700).
5. CPS ENERGY FURNISHED GRID-TIED DISCONNECT.

FIGURE 1100.2
 TYPICAL FUSE PAD DETAIL FOR CPS ENERGY SECONDARY GRID SERVICE
 FROM THE DOWNTOWN NETWORK SYSTEM

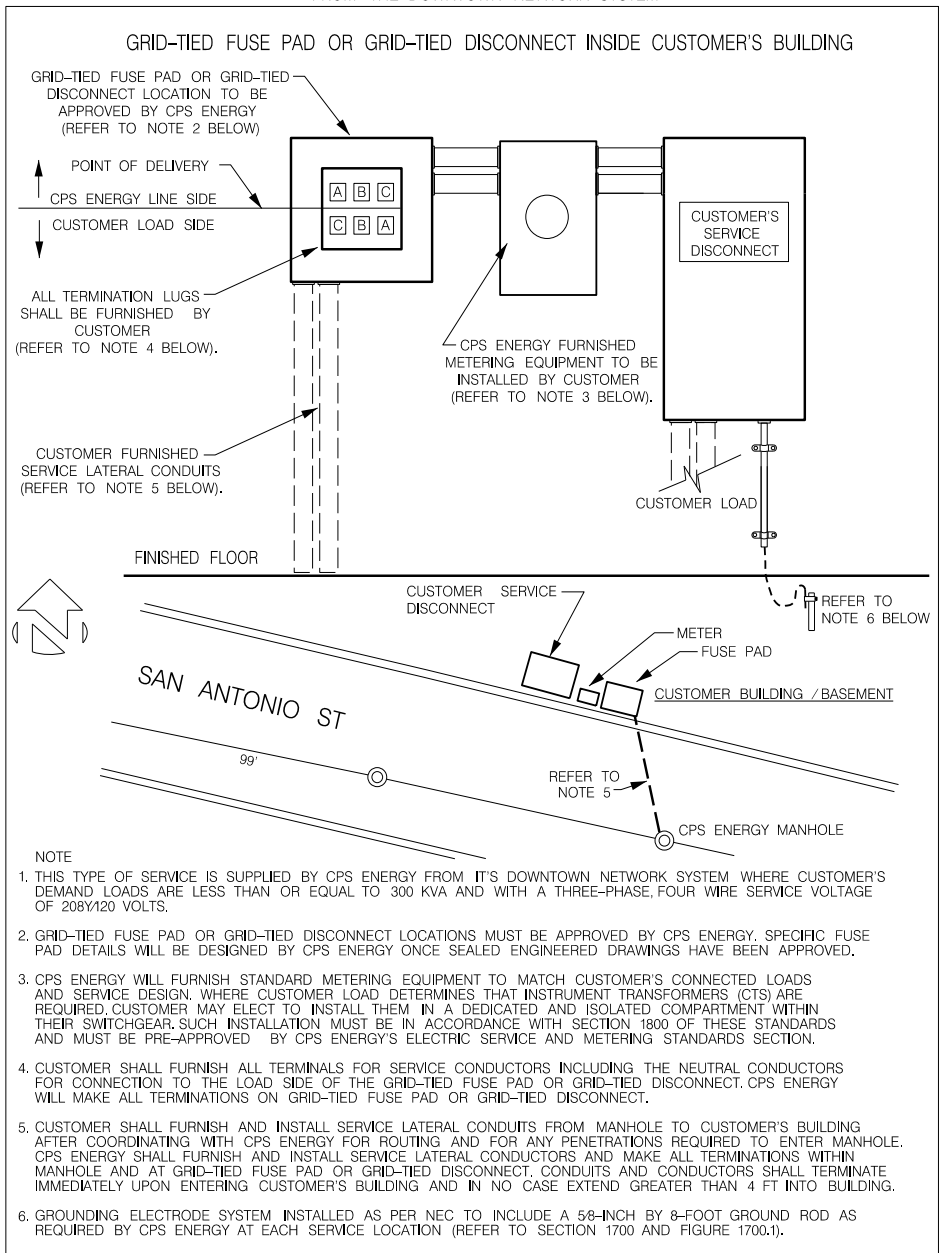
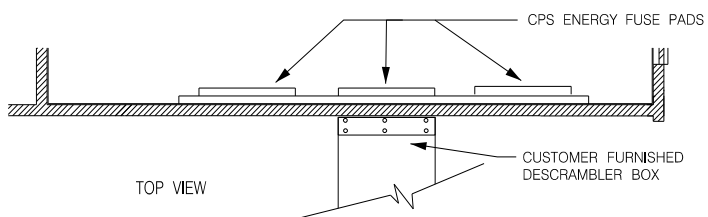
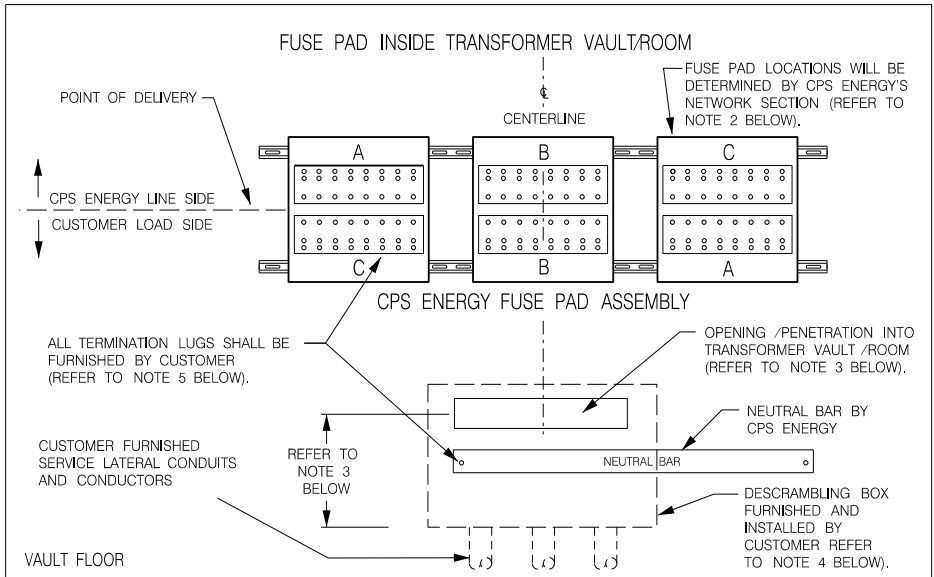

FIGURE 1100.3
 TYPICAL FUSE PAD DETAIL FOR CPS ENERGY TRANSFORMER VAULT/ROOM SERVICE
 FROM THE DOWNTOWN NETWORK SYSTEM



- NOTES:
1. THIS TYPE OF SERVICE IS SUPPLIED BY CPS ENERGY FROM ITS DOWNTOWN NETWORK SYSTEM WHERE CUSTOMER'S DEMAND LOADS ARE GREATER THAN 300 KVA AT 208Y/120-VOLT OR WHERE CUSTOMER REQUIRES 480/277-VOLT SERVICE VOLTAGE. CUSTOMER SHALL BE RESPONSIBLE FOR CONSTRUCTING A TRANSFORMER VAULT OR ROOM ON OR ADJACENT TO THEIR PREMISES IN ACCORDANCE WITH SECTION 1100.
 2. FUSE PAD LOCATIONS WILL BE DETERMINED BY CPS ENERGY'S NETWORK SECTION. SPECIFIC FUSE PAD DETAILS WILL BE DESIGNED BY CPS ENERGY ONCE SEALED ENGINEERED DRAWINGS HAVE BEEN APPROVED.
 3. OPENINGS /PENETRATIONS INTO CPS ENERGY TRANSFORMER VAULTS /ROOMS SHALL BE COORDINATED WITH CPS ENERGY FOR APPROVED HEIGHTS AND SUCH OPENING /PENETRATION SHALL BE SIZED AS NECESSARY FOR THE NUMBER OF CONDUITS OR THE SIZE OF THE BUSWAY WHERE USED. SUCH PENETRATION SHALL ALSO BE SEALED WITH FIRE PROOFING MATERIALS EQUAL TO THE RATING OF TRANSFORMER VAULT /ROOM WALL.
 4. DESCRAMBLING BOX FURNISHED AND INSTALLED BY CUSTOMER SHALL BE LOCATED ON EXTERIOR WALL OF CPS ENERGY'S TRANSFORMER VAULT/ROOM. DESCRAMBLING BOX SHALL BE SIZED IN ACCORDANCE WITH THE NEC AND CONSTRUCTED TO MEET CPS ENERGY SPECIFICATIONS AS OUTLINED IN SECTION 1100.
 NOTE: WHERE TRANSFORMER VAULT /ROOM DOES NOT PERMIT THE DESCRAMBLING BOX TO BE LOCATED IMMEDIATELY OUTSIDE OF VAULT /ROOM WALL. CPS ENERGY WILL PERMIT THE VAULT/ROOM TO HAVE A DEDICATED AREA CONSTRUCTED THAT WILL ALLOW FOR THE CABLES TO BE DESCRAMBLED. SUCH DEDICATED SPACE SHALL BE SIZED AS REQUIRED FOR THE NEC FOR JUNCTION BOXES BUT AT NO CASE BE LESS THAN 36 INCHES X 36 INCHES.
 5. CUSTOMER SHALL FURNISH ALL TERMINALS FOR SERVICE CONDUCTORS INCLUDING THE NEUTRAL CONDUCTORS FOR CONNECTION TO THE LOAD SIDE OF THE FUSE PAD (POD). CPS ENERGY SHALL MAKE ALL TERMINATIONS TO FUSE PAD AND NEUTRAL BAR INSIDE VAULT /ROOM.
 6. CUSTOMERS SHALL FURNISH AND INSTALL SERVICE LATERAL CONDUITS AND CONDUCTORS. WHERE SUCH CONDUITS AND CONDUCTORS ARE ROUTED UNDERGROUND FROM THE VAULT /ROOM TO CUSTOMER'S SERVICE EQUIPMENT NOT IMMEDIATELY ADJACENT TO THE VAULT /ROOM, THEY SHALL BE INSTALLED IN A MANNER THAT WILL RENDER THEM OUTSIDE THE BUILDING (REFER TO DEFINITION OF "CONDUCTORS CONSIDERED OUTSIDE OF BUILDING")

SECTION 1200

COMMERCIAL SERVICES FROM SINGLE-PHASE UNDERGROUND RESIDENTIAL DISTRIBUTION PADMOUNT TRANSFORMERS

**COMMERCIAL SERVICES FROM
SINGLE-PHASE UNDERGROUND
RESIDENTIAL DISTRIBUTION
PADMOUNT TRANSFORMERS**



1201 General:

This type of installation typically consists of underground primary voltage cables connected to the electric distribution system and installed in conduit to a CPS Energy owned single-phase Underground Residential Distribution (URD) padmount transformer located on **Customer's premises, Public Right-of-Way, and/or Adjacent Property**. Service is supplied to Customer from the padmount transformer's secondary terminals or secondary enclosure.

Note 1: Where the Customer can be served by overhead electric distribution facilities but requests an underground service, the Customer will be required to pay the cost difference from that of an overhead transformer service that could serve their load.

Note 2: CPS Energy will review and determine in conjunction with the appropriate authority having jurisdiction (AHJ) where it may be necessary to install a transformer in public ROW (i.e. telecommunications and wireless services, traffic signals, VIA bus shelters etc.).

1201.1 Easements for Underground Facilities:

CPS Energy facilities including primary distribution and overhead poles, transformers and pads, secondary laterals, and secondary enclosures will be installed in easements as determined by the CPS Energy Customer Service Representative. CPS Energy facilities may also be installed in alleys, streets, or other public right-of-way (ROW).

(A) Restricted Use of Easements:

Customer shall not permit any structure(s) such as: storage buildings, swimming pools, spas, decks, patios, car ports, garages, concrete walks and drives or equipment to be temporarily or permanently positioned over electric and/or gas lines or in their easements.

(B) Transformers: CPS Energy will determine the number and location of padmount transformers that will be installed. Customer shall furnish space meeting all clearance and easement requirements for each transformer and it shall be readily accessible.

Note 1: CPS Energy will not permit temporary or permanent structures to be placed in a manner that will obstruct CPS Energy access for maintenance or repair of CPS Energy Facilities, even if they are not located in an easement.

Note 2: While easements are not required for routing of URD service laterals and conduits, CPS Energy will not permit temporary or permanent structures to be placed in a manner that will obstruct CPS Energy access for maintenance or repair to service laterals and conduits.

1201.2 Call Before Digging:

Texas law requires anyone, including homeowners, who plan to excavate to notify 1(800)Dig TESS or 811 "One Call" for location of underground facilities at least two working days in advance so that the utilities' lines can be located and marked for safety (Refer to "Helpful Numbers" listed on the inside front cover page).

SECTION 1200 - COMMERCIAL SERVICE FROM SINGLE-PHASE UNDERGROUND
RESIDENTIAL DISTRIBUTION PADMOUNT TRANSFORMER

1201.3 Transformer Located on Customer Property:

(A) New Transformer:

Where a new URD transformer is to be installed, the primary distribution will be installed in accordance with Article 1204 and the service will be installed in accordance with Article 1205 and Figure 1200.1(A) (B).

Note 1: Review and approval shall be obtained from the Customer Service Representative to determine the interconnection to the existing distribution system.

Note 2: Property owner seeking to replat their property will be required to contact their CPS Energy Customer Service Representative for a separate service. Customer owned service conductors are not permitted to cross property lines even when properties are owned by the same Customer.

(B) Existing Transformer:

Where a commercial service installation is needed from an existing transformer, the Customer will be required to install a tap box in accordance with Article 1205.5 and Figure 1200.1(B).

Note 1: CPS Energy permits only one commercial service installation from a transformer secondary. Where additional Services are required, then a tap box will be installed in accordance with Article 1205.5.

Note 2: Property owner with an existing service seeking to replat the property will be required to contact their CPS Energy Customer Service Representative for a new service. Customer owned service conductors are not permitted to cross property lines even when properties are owned by the same Customer.

1201.4 Transformer Located in Public Right-of-Way:

(A) New Transformer:

Transformer installation in ROW shall be in accordance with Article 1205.2 will be reviewed by CPS Energy on a case by case basis. Where permitted, the primary distribution will be installed in accordance with Article 1204 and the service will be installed in accordance with Article 1205 and Figure 1200.1(C).

Note 1: Review and approval shall be obtained from the Customer Service Representative to determine how to interconnect to the existing distribution system.

(B) Existing Transformer:

Where a service and/or secondary is needed from an existing transformer, the service and/or secondary conduits will be installed in accordance with Article 1205.2.

Customer shall coordinate with CPS Energy on the termination of the conduits in the transformer pad and/or secondary enclosure.

Note 1: This type of service is not permitted where the secondary enclosure is part of an underground streetlight circuit unless reviewal and approval is coordinated by the Customer Service Representative.

SECTION 1200 - COMMERCIAL SERVICE FROM SINGLE-PHASE UNDERGROUND
RESIDENTIAL DISTRIBUTION PADMOUNT TRANSFORMER

Note 2: *Customer is not permitted to access energized CPS Energy equipment. Customer shall coordinate with CPS Energy for conduit and cable installation.*

1201.5 Existing Transformer or Secondary Enclosure Located on Adjacent Property:

Where a service and /or secondary is needed from an existing transformer or secondary enclosure, the service including secondary conduits will be installed in accordance with Article 1205, See Figures 1200.1(B and D).

Note 1: *Customer is not permitted to access energized CPS Energy equipment. Customer shall coordinate with CPS Energy for conduit and cable installation.*

1202 Sizing of CPS Energy Transformers:

Transformer type and size will be determined by the CPS Energy Customer Service Representative based on Customer's demand load.

1202.1 Demand Loads 250 kVA and Under:

Where Customer's demand load is equal to or less than 250 kVA, a standard single-phase URD type padmount transformer will be installed/utilized.

Note 1: *CPS Energy reserves the right to require a compartment type transformer for loads equal to or less than 250 kVA. CPS Energy will require a pour in place transformer slab adequate for the compartment type transformer, Refer to Article 1204.3 (B).*

1202.2 Demand Loads 250 kVA and Greater:

Where Customer's demand load is equal to or greater than 250 kVA, than a single-phase compartment type padmount transformer, similar to three-phase padmount transformers will be installed/utilized. This will require a pour in place transformer slab, Refer to Article 1204.3 (B).

1203 CPS Energy Job Sketch:

A Customer requesting service from a single-phase padmount transformer shall make arrangements with the CPS Energy Customer Service Representative. When all requirements have been met, CPS Energy will issue the Customer a detailed construction sketch for the construction of the transformer slab, associated primary, secondary, and service trench detail and conduits as applicable.

1204 Standard Installation:

A standard single-phase, URD padmount transformer installation will typically consist of the following:

1204.1 Primary Voltage Cable:

(A) From Overhead Distribution Circuits:

Primary voltage cables from CPS Energy's overhead distribution circuit to the primary terminals of the padmount transformer will be furnished and installed by CPS Energy. CPS Energy will install a riser pole, or use an existing pole, for the purpose of making the transition from the overhead circuit conductors to underground cable to supply the padmount transformer.

(B) From Underground Distribution Systems:

Primary voltage cables from an underground distribution circuit to the primary terminals of the transformer will be furnished and installed by CPS

SECTION 1200 - COMMERCIAL SERVICE FROM SINGLE-PHASE UNDERGROUND
RESIDENTIAL DISTRIBUTION PADMOUNT TRANSFORMER

Energy. Customers shall coordinate with the CPS Energy Customer Service Representative to determine service availability options from existing underground distribution systems.

1204.2 Primary Trench and Conduit:

The primary voltage cables shall be installed in conduits from the riser pole or other source up to the transformer slab. Customer shall install the trench and conduit in accordance with the standards outlined in this Section and other drawings/specifications issued by CPS Energy for single-phase padmount service installations. The conduits shall be continuous except for watertight couplings and shall be left clean with both ends plugged. Customer shall be responsible for furnishing all materials required for the installation of the trench and conduit.

(A) Number of Conduits:

The standard trench and conduit installation for a radial or loop feed to a single-phase padmount transformer shall consist of two 3-inch conduits unless otherwise instructed by the CPS Energy Customer Service Representative.

(B) Routing and Separation from Other Utilities:

The Customer will submit a proposed trench route and length for review and approval by CPS Energy. The trench proposal shall be a non-joint trench. The trench and conduit may not be installed under any permanent structure or building. In addition, the conduit must have a minimum of 12 inches of vertical separation from any other underground utility and 36 inches of horizontal separation.

Note: This does not preclude the customer from meeting all other utilities' clearance requirements (such as water, gas, telecommunications, etc.)

(C) Trench Length:

The minimum distance between riser pole and closest edge of transformer slab is 15 feet. The maximum trench length will be limited by the primary cable pulling tensions and will be determined by the CPS Energy Customer Service Representative. If a proposed trench and conduit length would result in the maximum allowable cable pulling tensions being exceeded, then the trench and conduit length will have to be reduced, or one or more pull boxes will be required.

(D) Approved Conduit Types:

The standard installation for underground conduits shall consist of PVC conduits, schedule 40 or schedule 80, rated for 90°C temperature, listed for aboveground and underground use. The elbows at the riser pole shall be schedule 80 and they shall be equipped with unthreaded PVC female adapters. CPS Energy may require that rigid metal conduit (RMC) or intermediate metal conduit (IMC) elbows be installed by the Customer at the riser pole.

Note 1: Where additional protection is deemed necessary by CPS Energy, schedule 80 PVC and/or concrete encasement may be required for entire installation.

SECTION 1200 - COMMERCIAL SERVICE FROM SINGLE-PHASE UNDERGROUND
RESIDENTIAL DISTRIBUTION PADMOUNT TRANSFORMER

(E) Installation:

A typical trench and conduit installation shall consist of PVC conduits arranged horizontally at the bottom of the trench. In addition, trench and conduit installations shall meet the provisions of (1) through (4) below:

- (1) Trench shall be of adequate depth and width to accommodate the specified conduits while maintaining a minimum of 30 inches of cover from final grade on private property and a minimum of 36 inches of cover in public ROW or as directed by other AHJ's such as TxDOT.
- (2) All joints and couplings shall be water-tight.
- (3) All conduits shall be left clean with both ends appropriately plugged in preparation for cable pulling. Customer shall provide a pull string in conduit(s).
- (4) Customer shall align the elbows with the CPS Energy conduit bracket at riser pole and connect the conduits to the CPS Energy riser conduits.

Note: Typically, CPS Energy will install the riser pole prior to the installation of Customer's trench and conduit to allow for proper alignment and coupling to CPS Energy's riser conduits. To facilitate the alignment, CPS Energy will install a conduit bracket on its pole two feet from finished grade, plus install a temporary 2-foot length of PVC conduits. Customer shall not disturb the CPS Energy riser conduits except as necessary to align their conduit elbows to the CPS Energy conduits. Customer shall not alter the position of the conduit brackets on the pole.

(F) Directional Boring:

Primary conduits may be installed via directional boring with prior approval by CPS Energy. Boring depths shall ensure that minimum cover and separation requirements specified by CPS Energy's job sketch are maintained. A CPS Energy inspector shall inspect the end points of the bore prior to conduits being extended and connected to riser conduits and transformer or pull box slab.

(G) Manholes and Pull Boxes:

Manholes and/or pull boxes may be required to be installed by Customer as part of the primary trench and conduit installation.

- (1) Materials and design of manholes and their covers shall be in accordance with CPS Energy specifications, which will be provided by the CPS Energy Customer Service Representative. Manholes and their covers must be inspected and approved by CPS Energy prior to and after their installation.
- (2) Pull boxes may be required to be installed by Customer as part of the primary trench and conduit installation. Customer shall install precast concrete slabs, provided by CPS Energy, for the installation of any required pull boxes. Pull box slabs shall be installed in accordance with CPS Energy specifications, which will be provided by the CPS Energy Customer Service Representative. The pull box slab installations must be inspected and approved by CPS Energy prior to and after their installation.

SECTION 1200 - COMMERCIAL SERVICE FROM SINGLE-PHASE UNDERGROUND
RESIDENTIAL DISTRIBUTION PADMOUNT TRANSFORMER

(H) Backfill Provisions:

Materials used to backfill the trench shall be clean and free of sharp objects. Customer shall be responsible for backfilling trench in accordance with CPS Energy specifications and/or all other (AHJ) requirements.

Exception: *Trench and conduit installations under streets or other drivable areas shall be backfilled with flowable fill to within 6 inches of final pavement surface.*

(I) Inspections:

A CPS Energy inspector shall inspect and approve all primary trench and conduit installations before the trench is backfilled. The City of San Antonio (COSA) or other AHJ inspectors do not make these inspections for CPS Energy. To schedule an inspection, Customer may contact the CPS Energy Customer Service Representative or refer to "Helpful Numbers" listed on the inside front cover page.

Note 1: *CPS Energy may require Customer to remove any or all of the backfill if an inspection was not performed prior to backfilling.*

Note 2: *CPS Energy may require Customer to remove or reinstall any CPS Energy facilities if an inspection were not performed as required or if the installation is not in accordance with CPS Energy's specifications.*

1204.3 Transformer and Pull Box Installations:

Single-phase padmount transformer and pull box if required, shall be located and their slabs installed in accordance with the following requirements:

(A) Location:

Customer shall provide CPS Energy with an approved location on their premises that is adequate for the transformer or pull box installation. For transformer and pull box that are to be installed in public ROW, the Customer shall provide written approval from the AHJ and shall install the transformer within 10 feet of the meter location. Customer shall furnish a site plan or drawing to CPS Energy that establishes the exact location of the transformer slab, and any required pull box slabs, with respect to permanent and identifiable structures. The location(s) shall provide for the following:

- (1) Open access to transformer and any required pull boxes, both vertically and horizontally, by equipment and personnel. Where located behind a wall or fence, the wall or fence may not be taller than 8 feet and must include a minimum 6-foot wide opening in front of each transformer and pull box.
- (2) 15-foot wide, all-weather drivable surface up to transformer slab, and pull box slab(s) if required, for access by CPS Energy equipment. Drivable surfaces shall meet the design criteria outlined by the CPS Energy Customer Service Representative.
- (3) Allow for 6 feet of clearance in front of each transformer or pull box slab (transformer or pull box door side) and 3 feet around sides and back. If possible, transformer and pull box doors shall face away from buildings or structures.

SECTION 1200 - COMMERCIAL SERVICE FROM SINGLE-PHASE UNDERGROUND
RESIDENTIAL DISTRIBUTION PADMOUNT TRANSFORMER

- (4) Appropriate clearances for transformer and pull box(es) away from building openings, stairways, fire escapes, etc.
- (5) No exposure of transformer or pull box(es) to corrosive vapors, steam cooling tower discharges, etc. that could damage it.
- (6) Protection by use of removable concrete filled bollards around transformer or pull box(es), where subjected to vehicular traffic.

(B) Slab Requirements:

Compartment type transformers sized at 250 kVA and greater will require Customer to construct custom slab in accordance with CPS Energy specifications provided by the Customer Service Representative.

The provisions of (1) through (5) below will be applicable for installation of transformer and/or pull box slabs:

- (1) The top of the slab shall be a minimum of 6 inches and a maximum of 12 inches above final grade.
- (2) There shall be no pipes, conduits, etc. under the slab except those necessary to supply primary to the transformer and those required to supply the electric load.
- (3) Where the subsoil conditions are questionable, CPS Energy shall require the Customer to provide a Proctor Density Test at their expense to establish whether the slab shall be installed on piers. A 90 percent Proctor Test is necessary to eliminate the need for piers.
- (4) Customer shall furnish and install two 5/8-inch x 8-foot copper or copper-clad ground rods in the slab opening, as specified in CPS Energy's slab detail. CPS Energy will provide and install all necessary ground rod connectors.
- (5) Where required by CPS Energy, an oil containment pit shall be constructed by Customer in accordance with specifications provided by the CPS Energy Customer Service Representative. Oil containment pits are required where oil capacity exceeds guidelines established by the Environmental Protection Agency (EPA) or the Texas Commission for Environmental Quality (TCEQ).

Note: Standard URD transformers and pull boxes shall be mounted on a precast concrete slab provided by CPS Energy.

(C) Inspections:

A CPS Energy inspector shall inspect the slab after it has been installed. COSA or other AHJ inspectors do not make these inspections for CPS Energy. To schedule an inspection, Customer may contact the CPS Energy Customer Service Representative (Refer to "Helpful Numbers" listed on the inside front cover page).

1205 Secondary and Service Lateral:

Secondary and service lateral exiting the transformer and/or secondary enclosure shall be totally enclosed in conduit. The conduits shall be

SECTION 1200 - COMMERCIAL SERVICE FROM SINGLE-PHASE UNDERGROUND
RESIDENTIAL DISTRIBUTION PADMOUNT TRANSFORMER

continuous except for watertight coupling. All conduits, elbows, and couplings shall be furnished by Customer as required below:

1205.1 Customer's Property:

Customer shall furnish, install, and maintain the service conduits and conductors between the single-phase transformer or secondary enclosure and Customer's service equipment. CPS Energy shall make all connections to transformer secondary terminals or in secondary enclosures.

1205.2 Public Right-of-Way:

Where a new transformer or secondary enclosure is approved by CPS Energy and the AHJ to be located in public ROW, Customer will furnish and install the secondary and/or service conduits from transformer and/or secondary enclosure to metering location.

CPS Energy will be responsible for installing and maintaining the secondary/service conductors to the point of demarcation (POD). Customer will be responsible for installation of the service-entrance conductors from the POD up to the metering location.

Where CPS Energy is serving *telecommunications, wireless services, traffic signals, and VIA bus shelters etc.*, then CPS Energy will install the service conductors up to the *meter location*.

EXCEPTION: *Where the service is from an existing transformer, CPS Energy will designate a location where the Customer will be responsible for furnishing and installing conduits (typically 5 feet from transformer or secondary enclosure). Customer shall coordinate with CPS Energy Representative on the final conduit stub-ups at transformer.*

Note 1: *Customer is not permitted to access energized CPS Energy equipment. Customer shall coordinate with CPS Energy for conduit and conductor installation.*

Note 2: *The maximum lateral distance from transformer or secondary enclosure to metering location shall be 250 feet (Reference Article 705.1).*

1205.3 Service Conduits:

The standard conduit installation requires the use of schedule 40 or 80 PVC conduits. The quantities and sizes of service conduits that may be connected to CPS Energy transformers and secondary enclosures will be determined by CPS Energy. Customer shall be responsible for coordinating with CPS Energy to ensure that the number and size of service conduits required for Customer's calculated loads will be in accordance with Table 1200.1.

Note 1: *Conduits are required to exit the bottom of the transformer through the slab.*

1205.4 Service-Entrance Conductors:

The maximum number and size of service-entrance conductors that may be connected to a CPS Energy transformer are identified in Table 1200.1 and depend on transformer kVA size. Where Customer elects to install conductors in excess of that allowed by Table 1200.1, the conductors shall terminate in

SECTION 1200 - COMMERCIAL SERVICE FROM SINGLE-PHASE UNDERGROUND
RESIDENTIAL DISTRIBUTION PADMOUNT TRANSFORMER

a Customer furnished and installed tap box pre-approved by CPS Energy, (see Article 1205.5).

The maximum number and size of service-entrance conductors that may be connected to a CPS Energy secondary enclosure are limited to 3-350 kCM conductors per phase. Where Customer elects to install conductors in excess of 3-350 kCM per phase, the primary will be required to extended onto the property and a new transformer must be installed. A tap box may be required if service-entrance conductors are in excess of that allowed by Table 1200.1.

1205.5 Tap Boxes:

Where a dedicated transformer is located on Customer property, CPS Energy shall permit one service lateral from the transformer secondary.

Where additional service laterals are needed and/or where the Customer's furnished conductors exceed the maximum number and size permitted in the transformer secondary, Customer shall furnish and install a pre-approved tap box in accordance with (1) and (2) below:

- (1) On installations with a standard URD transformer (250 kVA or less), Customer shall be responsible for installing underground conduits from the secondary side of the transformer to the tap box. CPS Energy will furnish and install conductors from the secondary terminal of the transformer to the tap box. Conduit details shall be provided by the CPS Energy Customer Service Representative and tap box shall meet requirements outlined in Section 1002.5 (D), Figure 1000.1 and 1000.2, and Table 1200.1.
- (2) On installations with a compartment type transformer (250 kVA and greater), Customer shall be responsible for installing a tap box with wireway and shall meet all requirements outlined in Section 1002.5 (D), Figure 1000.1 and 1000.2, and Tables 1200.1 and 1200.2.

1206 Metering:

The installation of the metering equipment shall be as instructed on the CPS Energy Job Sketch. Metering installation requirements will depend on the type of service installation being requested by the Customer. Refer to Article 1803 for CPS Energy furnished metering equipment and general installation requirements. Typical rack mounted, building wall mounted and multiple metering are outlined below:

(A) Rack Mounted Meter:

Rack mounted meter installations are available for all type of service installation from a single-phase padmount transformer or secondary enclosure, including multiple metering installations in accordance with Section 1800.

Note 1: *Metering equipment in ROW will be limited where CPS Energy is serving telecommunications, wireless services, traffic signals, and VIA bus shelters etc.*

(B) Building Wall Mounted Meter:

Meters may be mounted on building walls for any type of service installation from a single-phase padmount transformer or secondary enclosure, including multiple metering installations in accordance with Section 1800.

SECTION 1200 - COMMERCIAL SERVICE FROM SINGLE-PHASE UNDERGROUND
RESIDENTIAL DISTRIBUTION PADMOUNT TRANSFORMER

(C) Multiple Metering and Other Installations:

For multiple metering installations, or other CPS Energy approved installations the metering equipment shall be installed in accordance with Section 1800.

**TABLE 1200.1
MAXIMUM NUMBER OF CONDUCTORS FOR SINGLE-PHASE PADMOUNT TRANSFORMERS**

120/240-VOLT SINGLE-PHASE UNDERGROUND RESIDENTIAL DISTRIBUTION PADMOUNT TRANSFORMERS												
CPS Energy Standard URD Transformer	Maximum Allowable Number and Size in KCM of Conductors Per Phase That Customer May Install in the CPS Energy URD Transformer Shown by kVA Rating at Left-Most Column. Note: If These Values Are Exceeded or if Customer's Design Requires Splitting of Load at Transformer, Customer Shall Furnish and Install an Approved Cable Tapbox.											Conductors Per Phase CPS Energy Will Install if a Tapbox is Required
120/240V 1-Phase	Wire Type	1	2	3	4	5	6	7	8	9	10	(Note 4)
50 kVA	CU			1/0	4/0							1 - 350 kCM
	AL			3/0	4/0							
75 kVA	CU			4/0	4/0							2 - 250 kCM
	AL			250	4/0							
100 kVA	CU		500	300	350							2 - 350 kCM
	AL		500	500	500							
167 kVA	CU				350							3 - 350 kCM
	AL				500							
250 kVA	CU					500						4 - 350 kCM
	AL					500						

120/240-VOLT SINGLE-PHASE UNDERGROUND RESIDENTIAL DISTRIBUTION COMPACT PADMOUNT TRANSFORMERS												
CPS Energy Standard Padmount Transformer	Maximum Allowable Number and Size in KCM of Conductors Per Phase that Customer May Install in the CPS Energy Padmount Transformer Shown by kVA Rating at Left-Most Column. Note: If These Values Are Exceeded or if Customer's Design Requires Splitting of Load at Transformer, Customer Shall Furnish and Install an Approved Cable Tapbox.											Conductors Per Phase CPS Energy Will Install if a Tapbox is Required
120/240V 1-Phase	Wire Type	1	2	3	4	5	6	7	8	9	10	(Note 5)
250 kVA	CU						500					4 - 350 kCM
	AL						500					
333 kVA	CU						500					6 - 350 kCM
	AL						500					
500 kVA	CU						750					6 - 500 kCM
	AL						750					

Note 1: Customer shall furnish and install approved cable lugs in their tap box to receive CPS Energy 90 degrees C, conductors from CPS Energy Transformer (Refer to Figure 1000.1).

Note 2: Customer shall submit tap box shop drawings to CPS Energy's Electric Service Standards Section for review and approval prior to installation.

Note 3: Tap box shall be installed in accordance with Section 1000 and serve as the point of delivery.

Note 4: Cables will exceed the bottom of the URD transformer in accordance with Article 1205.5 (1).

Note 5: Refer to Table 1000.2 for cable wireway size for all 120/240-Volt Single-Phase Compact Transformers.

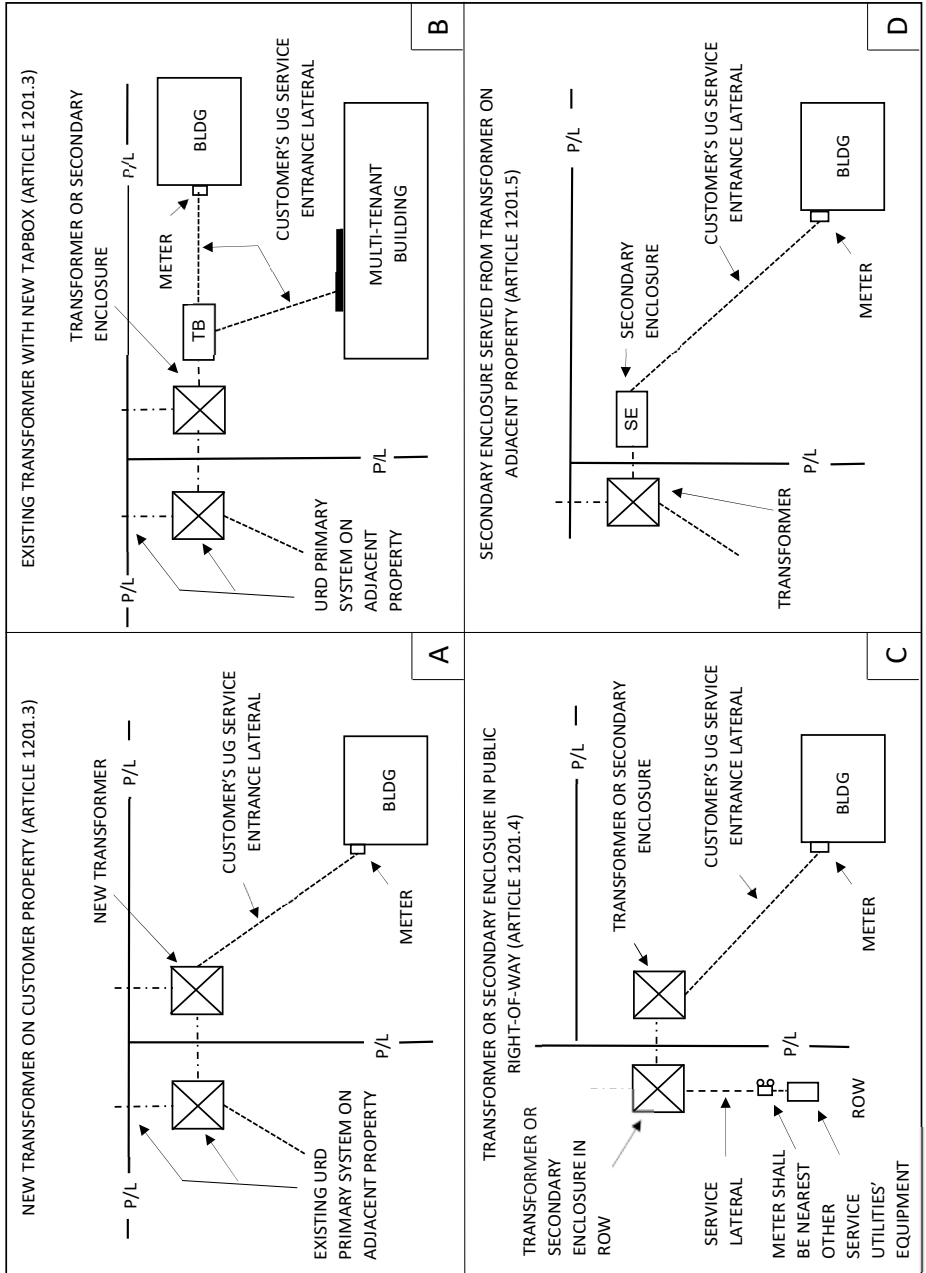

SECTION 1300

PRIMARY VOLTAGE SERVICE



1301 General:

CPS Energy offers either an overhead primary voltage service or an underground primary voltage service.

Standard overhead primary voltage service typically consists of a four-wire wye, three-phase voltage source supplied by CPS Energy from a distribution circuit to primary meter pole. The load-side of the primary current transformer (CT) bushing shall be considered the point of delivery (POD).

Standard underground primary voltage service typically consists of a four-wire wye, three-phase voltage source supplied by CPS Energy from a distribution circuit to an underground primary metering cabinet or dedicated primary metering compartment within Customer furnished and maintained primary switchgear. The load-side of primary current transformer (CT) bushing shall be considered the point of delivery (POD).

The three-phase, primary voltage service listed below may only be supplied with approval by CPS Energy. Where Customer requires a primary voltage service, they must contact the CPS Energy Customer Service Representative for proper coordination.

1302 Three-Phase Primary Voltage Service:

The following nominal primary voltages may be supplied by CPS Energy with prior approval and meeting minimum Customer load requirements:

- (1) 4160Y/2400-volt, four-wire, (minimum load required, 60 kVA)
- (2) 13200Y/7620-volt, four-wire, (minimum load required, 200 kVA)
- (3) 34500Y/19920-volt, four-wire, (minimum load required, 500 kVA)

Note: *The 4160Y/2400-volt or 13200Y/7620-volt services when approved by CPS Energy may require a step-down transformer to be installed on Customer premise which will affect the Point of Delivery (Refer to Definition of "Point of Delivery").*

1303 Multiple Primary Voltage Services (Primary Circuits):

Where CPS Energy approves additional services, Customer's equipment design and operational logic shall prevent any tie between multiple services at primary voltage.

1304 Overhead Voltage Service:

1304.1 CPS Energy Overhead Distribution Line:

CPS Energy will extend the overhead distribution line and terminate on a primary meter pole that shall be installed on Customer's premises at a readily accessible location.

1304.2 Customer's Overhead Electrical System:

Customer shall be responsible for furnishing and installing overhead service conductors from their first pole to CPS Energy's primary meter pole (POD). Customer's first pole shall be located between 50 and 100 feet from CPS Energy's primary meter pole. Customer shall provide sufficient conductor length for termination at CPS Energy's primary meter pole. Customer shall

be responsible for the installation, operation, and maintenance of their overhead electrical system.

Note: *At no time will Customer be permitted to accept overhead to underground primary service from CPS Energy's primary meter pole.*

1304.3 Customer's Service Equipment:

Customer shall install on their terminal pole suitable equipment for disconnecting their service and providing overcurrent protection. Customer's overcurrent device must be coordinated with that of CPS Energy. The highest rating or setting for the overcurrent protection device must be approved by CPS Energy.

1304.4 Lightning Surge Protection:

Lightning surge protection by Customer is not permitted to be installed on CPS Energy's primary meter pole. All lightning surge protection shall be installed in accordance with applicable codes.

1304.5 Multiple Services at Primary Voltage:

Where CPS Energy approves additional services, Customer's equipment design and operational logic shall prevent any tie between multiple services at primary voltage.

1304.6 Primary Metering:

The standard overhead installation for primary metering equipment shall be rack mounted and installed on primary meter pole. All overhead primary metering equipment shall be installed by CPS Energy.

Where Customer elects padmount primary metering equipment for 13200Y/7620-volt service or 34500Y/19900-volt service, then Customer will be required to install a primary ductbank and slab per CPS Energy specifications. CPS Energy will furnish and install primary voltage conductors and primary metering equipment (Refer to Article 1309).

1305 Underground Voltage Service:

1305.1 CPS Energy Primary Voltage Ductline and Primary Voltage Cable:

Customer shall furnish and install primary voltage ductline per CPS Energy specifications. Where serving a primary metering cabinet, Customer shall be responsible for the construction of the slab for the primary metering cabinet in addition to the primary ductbank. Where serving a dedicated primary metering compartment within Customer's switchgear, Customer shall terminate primary ductbank to this dedicated compartment.

CPS Energy will furnish and install the primary voltage cable and make all necessary terminations. Customer shall provide the necessary terminals and be responsible for terminating the primary voltage cables to Customer owned switchgear.

1305.2 CPS Energy Primary Voltage Ductline Entering Buildings or Other Structures:

Where CPS Energy owned primary voltage cable must enter a building to terminate in a Customer furnished primary metering switchgear compartment, the conductors shall be installed in a manner that will render them to be

considered outside of the building. Customer will be responsible for meeting this requirement and for the maintenance of that portion of the ductline within their slab and building (Refer to Definition of "Conductors Considered Outside of Building").

Two inspections are required for concrete encased ductlines. A CPS Energy inspector shall inspect and approve all primary ductlines and manholes before the conduits within the underground ductline are encased in concrete and a second inspection is required before the trench is backfilled. City inspectors or other AHJ inspectors do not perform these inspections. To schedule an inspection, Customer may contact the CPS Energy Customer Service Representative or refer to "Helpful Numbers" listed on the inside front cover page.

Note: *CPS Energy reserves the right to require Customer to remove any or all of the backfill and concrete if an inspection was not performed as required.*

1305.3 Step-Down Transformers:

Where CPS Energy approves Customer's request for primary voltage service of 4160Y/2400-volt or 13200Y/7620-volt, CPS Energy may require that a step-down transformer be installed on Customer's premises.

Customer shall furnish and install primary voltage ductline (line-side) and transformer slab in accordance with CPS Energy specifications. Where transformer supplies CPS Energy primary metering cabinet, Customer shall be responsible for furnishing and installing load-side conduits, and primary metering cabinet slabs. CPS Energy will furnish, install, and terminate primary voltage cables between step-down transformer and primary metering cabinet.

Customer shall be responsible for all load-side conduits and conductors including terminals.

- (1) Where a step-down transformer is used to provide 4160Y/2400-volt service, the POD shall be at load-side of CT bushing installed at CPS Energy transformer.
- (2) Where a step-down transformer is used to provide 13200Y/7620-volt service, the POD shall be at secondary spade of step-down transformer when supplying a primary metering compartment located in Customer's switchgear. Where supplying CPS Energy furnished padmount primary metering cabinet, the cabinet must be located outside on Customer's premise and the POD shall be at the load-side of CT bushing installed at the primary metering cabinet.

Note 1: *Customer installed ductline shall be in accordance with Section 1000.*

Note 2: *CPS Energy will terminate Customer load-side conductors at transformer secondary. CPS Energy will furnish and install the line-side, primary voltage cable and make all terminations at CPS Energy transformer.*

Note 3: *Two inspections are required for transformer slabs. A CPS Energy inspector shall inspect the slab after forms, reinforcing steel, primary and secondary conduits, metering conduit(s) and ground rods are in place, and the installation is ready for concrete pouring. A second inspection is required after the concrete has been poured and all forms have been removed. City inspectors or other AHJ inspectors do not perform these inspections. To schedule an inspection, Customer may contact a CPS Energy Customer Service Representative or refer to "Helpful Numbers" listed on the inside front cover page.*

Note 4: *CPS Energy reserves the right to require Customer to remove any or all of the concrete and surrounding fill to expose reinforcing steel, footings, etc. when a slab inspection was not obtained prior to it being poured.*

1305.4 Customer's Service Equipment:

Customer shall provide the necessary service equipment disconnecting means and overcurrent protection equipment. Customer's overcurrent device must be coordinated with that of CPS Energy. The highest rating or setting for the overcurrent protection device must be approved by CPS Energy. Customer shall submit switchgear drawings for approval to the CPS Energy Customer Service Representative (Refer to Section 1800).

1305.5 Primary Metering:

Primary metering equipment may either be installed in transformer secondary compartment (4 kV only), in primary metering cabinet or in Customer's furnished primary switchgear. If primary metering cabinet option is selected by Customer, CPS Energy will furnish and install the primary metering cabinet at Customer's expense. Customer must furnish a concrete slab as specified by CPS Energy (Refer to Article 1305 Note 3 for inspection requirements). Where Customer furnished primary switchgear option is selected, Customer shall provide a dedicated metering compartment in their switchgear and coordinate with CPS Energy to have primary metering equipment shipped to and installed in primary switchgear by manufacturer prior to delivery (Refer to Section 1800).

SECTION 1400

SERVICE TO CUSTOMER OWNED METER POLE



1401 General:

Where Customer requests electric service and is not allowed to or chooses not to have their meter loop installed on their building or structure, they may install a meter pole in accordance with the provisions herein on their premises.

Note: *CPS Energy will not provide or install transformers or primary voltage conductors on a Customer owned meter pole.*

1401.1 Services Requiring Meter Pole:

A meter pole (if overhead service is taken) is a requirement for receiving service to a manufactured home, temporary or portable building, and/or other structures deemed by CPS Energy not to be suitable for direct supply by CPS Energy owned and maintained service drops.

1401.2 Customer Owned and Maintained:

Where a Customer meter pole is utilized, it shall be owned and maintained by Customer in a safe condition as determined by CPS Energy (Refer to Figures 1400.1 and 1400.2 for typical installations).

Note: *Customer load conductors may leave the meter pole either underground or overhead.*

1401.3 Location of Meter Pole:

The meter pole shall be located on Customer's premises in a readily accessible area. Installation of meter poles under CPS Energy primary distribution lines or in a CPS Energy electric easement is prohibited. Customer shall coordinate with the CPS Energy Customer Service Representative.

1401.4 Approved Types of Poles:

The meter pole structure shall be a chemically treated wood pole, steel I-beam, pipe or equivalent. A wood pole shall not be less than 5 inches in diameter at the top and it shall be tall enough to satisfy the clearances of service drops and drip loops as specified in Section 500 and shown in Figure 500.1.

Steel I-beam, pipe, or equivalent may be used by Customer where specifications and design are first approved by CPS Energy. A pipe shall be a minimum of 4 inches in diameter while I-beam must be a minimum 4 inches by 4 inches. The meter pole shall provide adequate anchorage to the service conductors and all equipment it supports.

Note: *In situations where CPS Energy provides underground supply, a meter pedestal approved by CPS Energy's Electric Service and Metering Standards Section may be installed (Refer to Definition of "Meter Pedestal" and Figure 1500.1).*

1402 Installation of Meter Pole:

Customer may install their own chemically treated meter pole, but its type and installation must meet CPS Energy standards and in no case be less than 6 feet deep into the ground. Upon Customer request, CPS Energy will install a chemically treated wood pole for Customer at their expense.

(A) Steel I-Beam or Pipe Type:

Steel I-beam or pipe must be installed by Customer and it shall be set in concrete to a minimum depth of 48 inches. Steel I-beams or pipe shall provide adequate contact points for service conductors as required and acceptable by the CPS Energy Customer Service Representative. A 5/8-inch hole for anchorage shall be pre-drilled 12 inches above the service head and not less than 12-inches below the top of the pole as shown in Figure 1400.1.

(B) Damaged/Deteriorated Poles:

Rotted wood poles, deteriorated steel poles or I-beams, or poorly set meter poles, that are deemed unsafe by CPS Energy shall be repaired or replaced by Customer. Failure to remedy the unsafe situation may be cause for disconnection of service.

1403 Service Equipment:

Customer's service equipment shall be installed in accordance with NEC and other applicable codes including Sections 400 and 1800 of these Standards. Customer service equipment shall be located on the meter pole as shown in Figure 1400.1 and 1400.2.

(A) Service Drop:

The service drop shall satisfy the clearances specified in Section 500 and shown in Figure 500.1 and shall be attached on meter pole at no more than 12 inches from the service head of Customer's service raceway (Refer to Figure 1400.1 and 1400.2).

(B) Customer Load Conductors:

Where Customer elects to leave meter pole with overhead load conductors, the point of attachment for Customer's overhead load wires shall be 36 inches minimum, below the service head. Customer will be responsible for providing all load-side clearances for secondary conductors as required by the NEC and other applicable codes.

Note 1: *At no time will Customer be allowed to rely on a CPS Energy primary fuse disconnect to protect service-entrance conductors on a meter pole or other services.*

Note 2: *Customer's grounding electrode shall be located at the service equipment and be installed as per NEC and Section 1700.*

1404 Metering Equipment:

Metering enclosures shall be positioned so that the meter will face toward the street. Metering instrument transformer enclosures, including transockets, shall not be mounted on meter pole.

Where approved for use by CPS Energy, meter racks may be installed to support equipment that does not properly fit on pole. Customer shall furnish and install rack in accordance with CPS Energy specifications (Refer to Figure 1400.2).

1405 Other Equipment Not Permitted on Meter Pole:

Devices other than service and load conductors, metering equipment, and service equipment shall not be placed on the meter pole. Security lights may be installed on Customer's meter pole where first approved by the CPS Energy

SECTION 1400 - SERVICE TO CUSTOMER OWNED METER POLE

Customer Service Representative and after proper clearance (36 inches) to the service drop conductors and drip loop is maintained.

Exception: Where meter pole is used for telecommunication systems in accordance with Section 1900.

FIGURE 1400.1
OVERHEAD SERVICE, SELF-CONTAINED METER(S) ON CUSTOMER-OWNED METER POLE

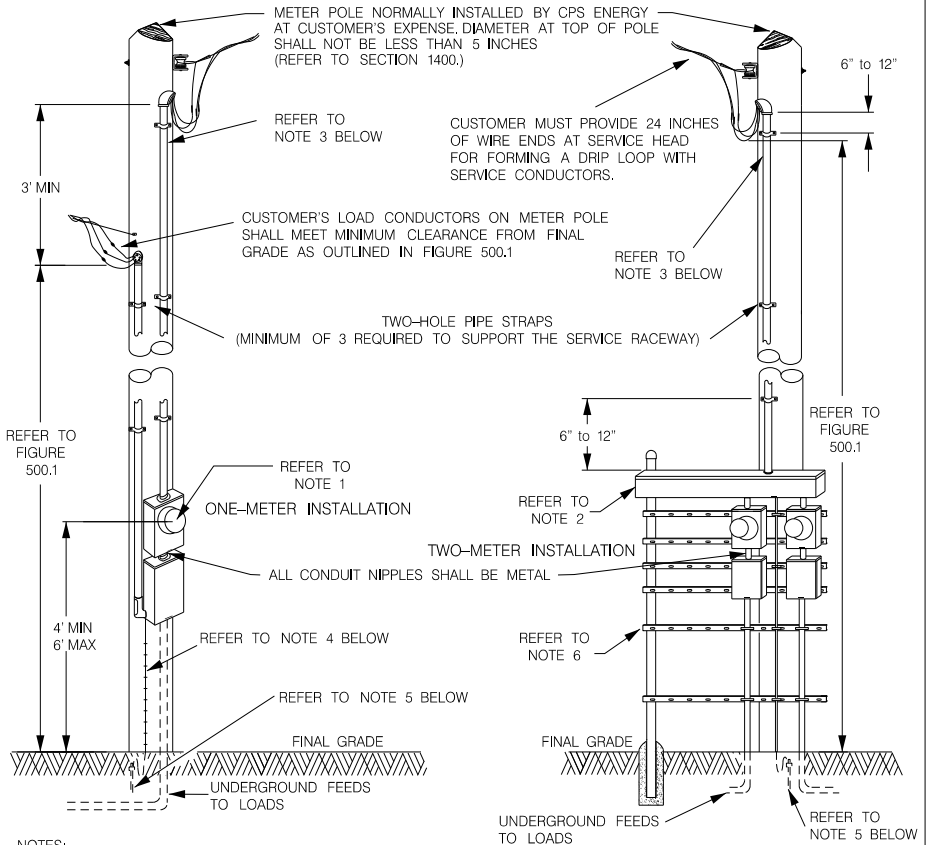

NOTES:

1. CPS ENERGY APPROVED SINGLE-PHASE SELF-CONTAINED METER SOCKET WITH BOLT-ON HUB FURNISHED AND INSTALLED BY CUSTOMER REFER TO FIGURE 1800.1, METER SOCKET, ETC. MUST BE MOUNTED DIRECTLY TO POLE OR TO METAL BRACES; WOODEN BACKERS ARE NOT PERMITTED. METERS MUST BE MOUNTED SO THAT THEY WILL FACE THE STREET.
2. METER GUTTER WITH WEATHERPROOF CONDUIT HUB FURNISHED AND INSTALLED BY CUSTOMER. CUSTOMER MAKES ALL CONNECTIONS IN GUTTER. SIZING OF GUTTERS SHALL BE AS PER NEC BUT IN NO CASE LESS THAN 8 INCHES HIGH WITH 3/0 AWG CONDUCTORS OR SMALLER AND NOT LESS THAN 10 INCHES HIGH WITH CONDUCTORS LARGER THAN 3/0 AWG OR ANY COMBINATION OF PARALLELED CONDUCTORS.
3. SERVICE RACEWAYS FURNISHED AND INSTALLED BY CUSTOMER SHALL NOT BE LESS THAN 1 1/4-INCHES AND SHALL BE EITHER IMC, RIGID OR EMT.
4. COPPER GROUNDING ELECTRODE CONDUCTOR (FURNISHED AND INSTALLED BY CUSTOMER, SIZE AND INSTALLATION IN ACCORDANCE WITH NEC, CONDUCTORS SMALLER THAN NO. 6 MUST BE ENCLOSED IN CONDUIT OR CABLE ARMOR.)
5. GROUNDING ELECTRODE SYSTEM INSTALLED AS PER NEC TO INCLUDE 5/8-INCH X 8-FOOT GROUND ROD AS REQUIRED BY CPS ENERGY AT ALL CUSTOMER SERVICE LOCATIONS (REFER TO SECTION 1700)
6. EQUIPMENT RACK USED IN CONJUNCTION WITH METER POLE FOR SUPPORT OF EQUIPMENT MUST BE CONSTRUCTED IN ACCORDANCE WITH FIGURE 1800.20.

FIGURE 1400.2
OVERHEAD SERVICE, WEATHERPROOF CT'S ON CUSTOMER-OWNED METER POLE

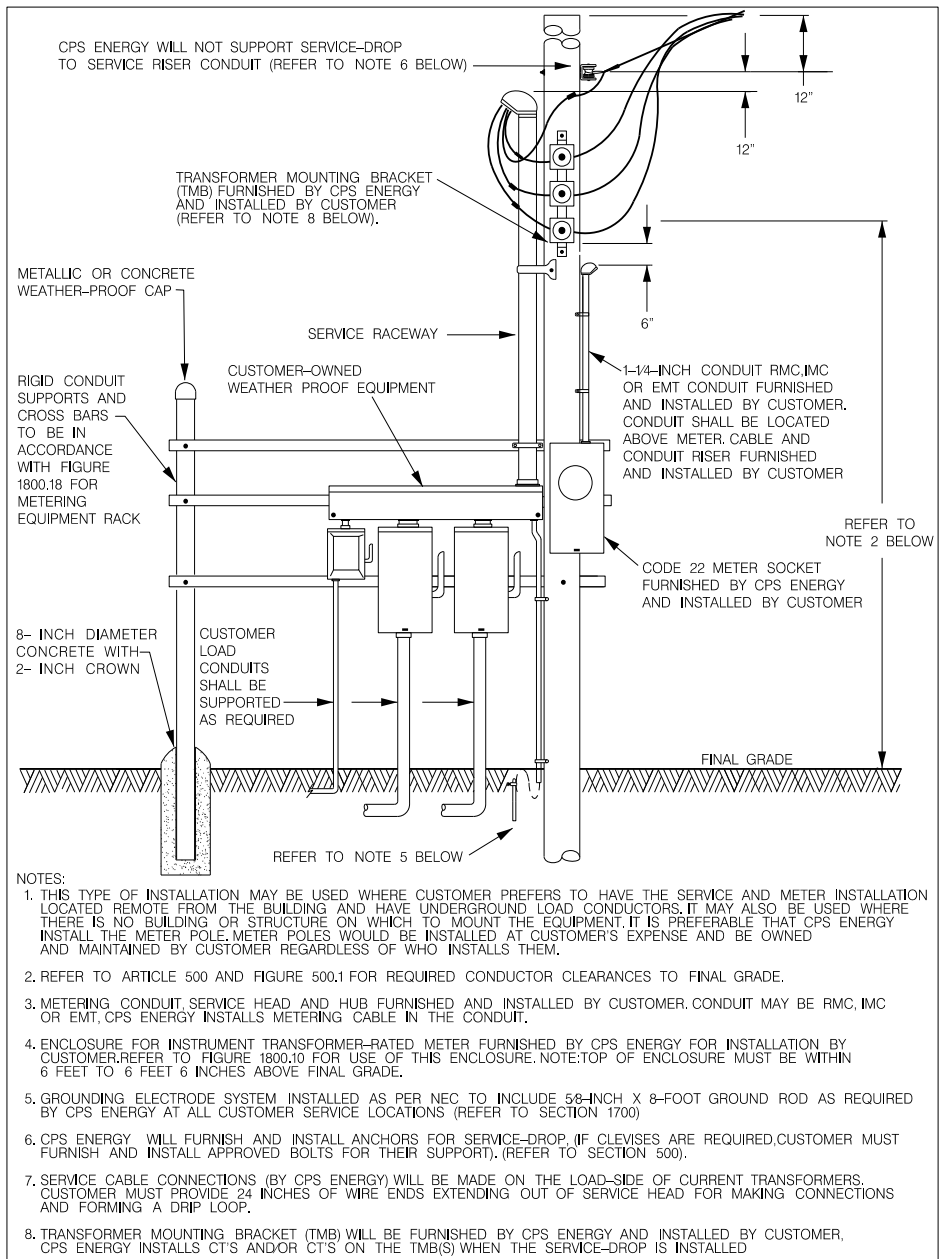

SECTION 1500

**SERVICE IN MANUFACTURED
HOME COMMUNITIES**

SERVICE IN MANUFACTURED
HOME COMMUNITIES





1501 General:

Service to manufactured homes within a Manufactured Home Community may be supplied from an underground or an overhead distribution system. Customer may request service from either type of system with the CPS Energy Customer Service Representative (Refer to "Helpful Numbers" listed on the inside front cover page).

1501.1 Final Grades Provided by Customer:

Customer is responsible for providing finished grades before CPS Energy installs transformers and trenches for primary voltage ducts and secondary laterals. In cases where the final grades are changed after CPS Energy has begun the installation of the infrastructure, the re-design and construction charges associated with the changes will be the Customer's responsibility. Customer shall identify all property lines as required by CPS Energy.

1501.2 Easements for CPS Energy Facilities:

CPS Energy facilities such as overhead and underground primary voltage cable, transformers, secondary laterals, secondary enclosures, service laterals, and service drops, may be installed in rear lot, front lot, or other dedicated easements. CPS Energy facilities may also be installed in alleys, streets, or other public right-of-way as deemed necessary. If transformers are installed in rear lot or dedicated easements, transformers shall be installed adjacent to a drivable surface.

(A) Restricted Use of Easements:

Customer shall not permit any structure(s) such as: storage buildings, swimming pools, spas, decks, patios, car ports, garages, concrete walks, and drives or equipment to be temporarily or permanently positioned over electric and/or gas lines or in their easements.

Note: While easements are not required for routing of URD service laterals and conduits, CPS Energy will not permit temporary or permanent structures to be placed in a manner that will obstruct CPS Energy access for maintenance or repair to service laterals and conduits.

(B) Call Before Digging:

Texas law requires anyone, including homeowners, who plan to excavate to notify 1(800) Dig Toss or 811 "One Call" for location of underground facilities at least two working days in advance so that the utilities' lines can be located and marked for safety (Refer to "Helpful Numbers" listed on the inside front cover page).

1501.3 CPS Energy Facilities and Maintenance:

CPS Energy will own, operate, and maintain transformer installations, primary and secondary cables, conduits, secondary enclosures, service laterals, and kWh meters. CPS Energy may perform maintenance as required to meter sockets.

1502 Underground Residential Distribution System (URD):

URD Systems for Mobile Home Communities shall be installed in accordance with Section 700 of these Standards, with the following exceptions:

- (1) The service lateral trench and conduits shall be furnished and installed by CPS Energy. Customer shall furnish and install trench and conduit for all other installations.

Note: *Customer shall not stub-up conduits into energized pedestals or transformers.*

- (2) CPS Energy will furnish and install the service lateral from the transformer terminals or secondary enclosure directly into a metering pedestal that is furnished and installed by the Customer (Refer to Section 1800 and Figure 1500.1).
- (3) Surface type meter mounting pedestals furnished and installed by Customer. Customer's weatherproof service equipment and power outlet may be mounted on the pedestal. Meter pedestals shall be mounted on or concrete embedded in a minimum 18-inch diameter by 20-inch depth concrete base. Meter pedestals shall meet all specifications and be approved by CPS Energy prior to installation (Refer to Figure 1500.1). Customer shall install the pedestal as specified in Section 1800 and Shown in Figure 1500.1. Customer must notify CPS Energy in advance as to the type of pedestal to be used.

Note: Only one meter per pedestal shall be permitted by CPS Energy.

- (4) Where Customer elects not to use a meter pedestal they may construct and utilize metering equipment rack approved by CPS Energy for the mounting of single-position meter sockets and Customer's service equipment (Refer to Definition of "Metering Equipment Rack" and Figure 1800.20). The CPS Energy Customer Service Representative will review and approve proposed equipment installation design. Design submittal must include the number of meters, the size and rating of service equipment, conductor sizes, and estimated demand load requirements.
- (5) Meter sockets shall not be mounted on manufactured homes.
- (6) Meter pedestals/meter equipment rack shall be permanently labeled with the address and where necessary with a description of the equipment or structure it supplies.

1503 Overhead Distribution System:

A standard installation will typically consist of the basic equipment and steps listed in (1) through (5) below. Customer shall review the referenced articles for more specific information and requirements.

- (1) Main-line poles, primary voltage lines, overhead distribution transformers, and secondary lines furnished and installed by CPS Energy in easements furnished by Customer.
- (2) Service drops furnished and installed by CPS Energy as required. The cable will run from the pole mounted transformer terminals directly to the service-entrance (drip loop) conductors provided by Customer at CPS Energy approved Customer meter pole.
- (3) Meter poles shall be in accordance with Section 1400.
- (4) CPS Energy approved single-phase, self-contained meter sockets furnished and installed by Customer.

SECTION 1500 - SERVICE IN MANUFACTURED HOME COMMUNITIES

(5) Meter sockets shall not be mounted on manufactured homes.

Note 1: *All applicable parts of Section 500 for overhead services will apply to overhead systems in manufactured home communities.*

Note 2: *CPS Energy shall make all connections to service drop conductors.*

Note 3: *Overhead to underground service installations shall meet the requirements for URD installations as outlined in Article 1502 for the exception that the Customer will be responsible for furnishing and installing the service lateral conduit from transformer pole to meter pedestal.*

FIGURE 1500.1
STANDARD METER PEDESTAL INSTALLATION

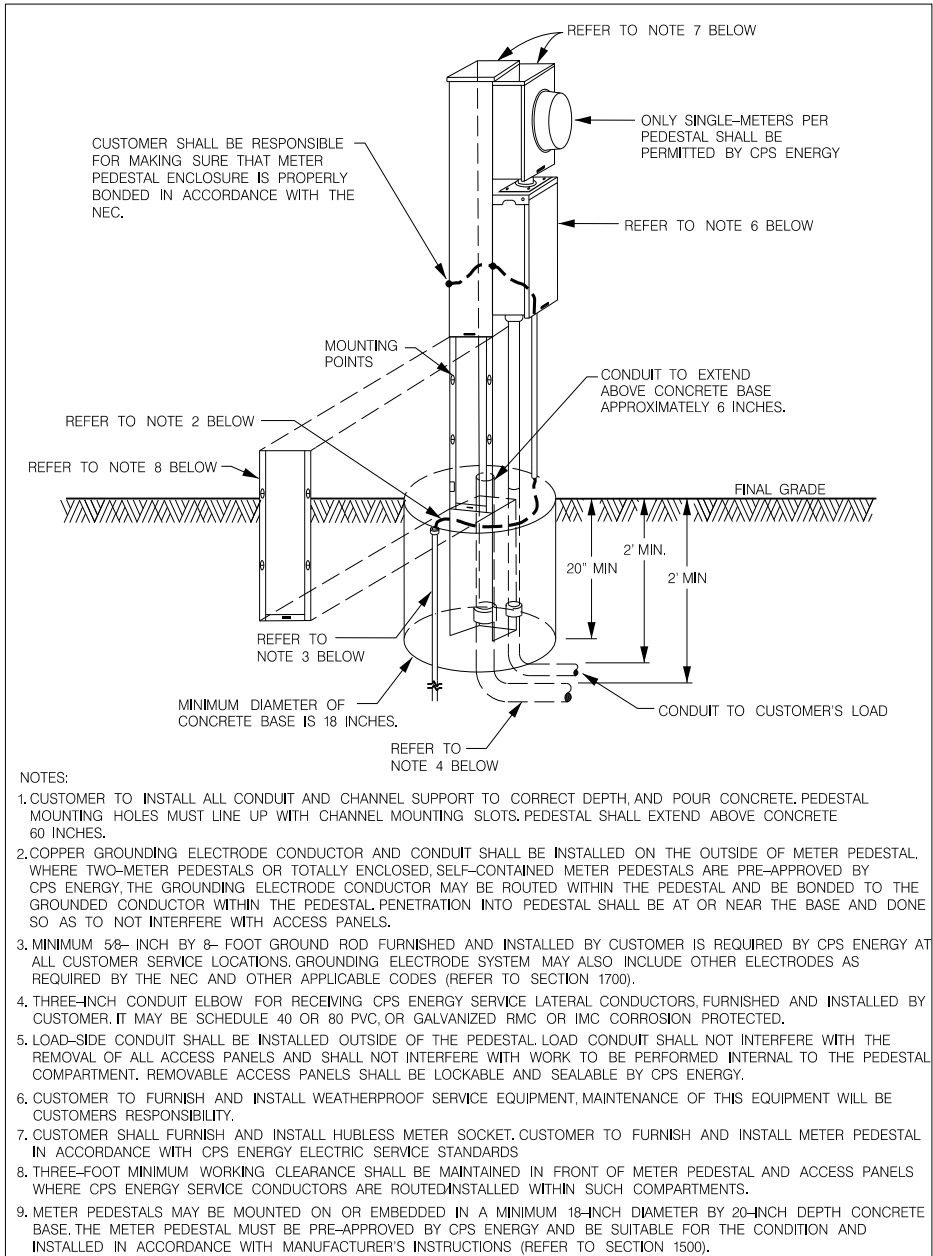

SECTION 1600

TEMPORARY SERVICE



1601 General:

CPS Energy will supply power for a temporary service that is to be used for construction power, provided an approved structure with a meter loop is installed by Customer. A stand-alone temporary meter structure (temporary meter loop) meeting construction provisions outlined herein is required (Refer to Figures 1600.1 and 1600.2).

Before CPS Energy energizes the temporary service, Customer must satisfy permitting requirements with the authority having jurisdiction (AHJ), and the AHJ must release these permits. The street address must be legibly and permanently marked or attached on the temporary structure, but not on the meter socket cover. Temporary structures shall not be moved while energized.

Note: *CPS Energy will not supply electric service to any meter loop located on or attached to portable type structures or buildings (Refer to Definition of "Portable").*

1602 Construction of Temporary Meter Structure:

The temporary structure must be of sound construction. A minimum of 4-inch x 4-inch wooden mast shall be set a minimum of 2 feet in the ground and be supported by a minimum of three 2-inch x 4-inch braces and stakes. Top braces are to be secured to temporary structure within 18 inches from top of structure for URD services or 18 inches below service head for Overhead services (Refer to Figures 1600.1 and 1600.2).

Note: *Where temporary three-phase services are requested, a Customer owned meter pole in accordance with Section 1400 shall be installed for overhead services and where supplied from an overhead to underground or underground service, then Customer shall be required to construct a metering equipment rack in accordance with Figure 1800.20.*

1603 Temporary Service Laterals in URD Areas:

Service laterals furnished and installed by Customer from CPS Energy padmount transformers or secondary enclosures may supply Customer's service on temporary meter structures in URD areas. The standard method will be from padmount transformers (Refer to Definition of "Service Lateral").

Note: *All applicable Articles of Section 700 for URD systems will apply to temporary service installations in URD areas.*

1603.1 Location of Temporary Meter Structure:

The structure shall be located within 2 feet and in line with the rear of the supplying transformer's pad. It shall be constructed with the meter positioned to face the street or alley. Transformer lid padlock is always located on the front of the transformer (Refer to Figure 1600.1).

Where transformer is located on an adjacent property and the property owner objects to the temporary meter loop, it may be moved to adjoining undeveloped property utilizing CPS Energy's easement, but as close to transformer as possible. The temporary meter loop shall face towards the street or alley.

Note 1: *Where a secondary enclosure supplies a temporary meter loop, such loop shall not be installed closer than 3 feet to secondary enclosure.*

Note 2: *Where installing a ground rod at the temporary meter structure location, Customer shall not drive ground rod at an angle toward the side of the transformer or toward the front side of transformer. Customer shall be responsible for ensuring that ground rod installation will not cause damage to CPS Energy underground infrastructure.*

1603.2 Service Lateral and Conduits:

Customer shall furnish and install service lateral conduits and conductors for temporary meter loops from transformer or secondary enclosure. The conduit(s) for the lateral conductors shall be installed in accordance with (1) through (4) below:

Note 1: *Customer shall not dig under CPS Energy transformers or secondary enclosures. CPS Energy will connect the service lateral conductors to the transformer in a manner that will not leave any portion of the conductors exposed.*

Note 2: *Customer shall backfill trench immediately after placement of conduit(s) and shall provide marking on surface along trench route so as to identify its location. Marking shall be such that it will stay for the duration of temporary service usage.*

- (1) Conduits shall be 1 1/4 inches minimum size unless otherwise specified by the CPS Energy Customer Service Representative.
- (2) Conduits shall be a type approved for direct burial and be rigid metal conduit (RMC), intermediate metal conduit (IMC), schedule 40 or 80 PVC conduit, or flexible nonmetallic liquid tight conduit. Where flexible nonmetallic conduit is used, it shall be left long enough to extend into transformer or secondary enclosure.
- (3) Conduits shall be buried with not less than 12 inches of cover to the top of conduits from final grade and be provided with marker warning tape to warn excavators and to prevent damage or personal injury.
- (4) Conduits shall be continuous from the connection at the Customer metering enclosure to a point in the trench that is within 6 to 12 inches from CPS Energy's transformer or secondary enclosure (Refer to Figure 1600.1).

Exception: *For residential use of temporary meter structures only RMC, IMC or Schedule 80 PVC conduits may be run above ground where not crossing property lines, not over 10 feet, and not subjected to physical damage or vehicular traffic including construction related equipment. Conduits must be anchored sufficiently to prevent them from pulling away from transformer and temporary meter structure. CPS Energy shall make final determination on the conduits being subjected to physical damage.*

1604 Temporary Service Drops in Overhead Areas:

A temporary service drop will be installed by CPS Energy to a temporary structure approved by CPS Energy that is provided with a meter loop; both structure and meter loop installed by Customer. All temporary services shall be inspected and approved by the respective AHJ.

Note: All applicable Articles of Section 500 for Overhead systems will apply to temporary service in overhead areas.

1604.1 Location of Temporary Meter Structure:

The structure shall be located within the Customer's premises at a minimum distance of 15 feet and a maximum distance of 100 feet from CPS Energy's main-line pole with a maximum load of 25 kVA. Working clearances about temporary meter loop equipment shall be in accordance with Section 1800.

1604.2 Service-Entrance Conductors (Service Raceway):

Customer shall provide and install the temporary service-entrance conductors and service raceway from CPS Energy's service drop conductors to metering equipment (Refer to Definition of "Service-Entrance Conductors"). Customer shall be responsible for installing conductors in accordance with (1) through (3) below:

- (1) Customer shall provide a minimum of 24 inches of free conductor for connection to service drop by CPS Energy.
- (2) Conductors shall be installed in approved raceways of RMC, IMC or EMT. Service raceway shall be a minimum of 1 1/4 inches and be securely supported to Customer's temporary meter structure.
- (3) Drip loop conductors and service drop conductors shall be installed so as to maintain the minimum vertical clearance requirements outlined in Section 500 and shown in Figure 500.1.

FIGURE 1600.2
 TEMPORARY METER INSTALLATION, OVERHEAD SERVICE

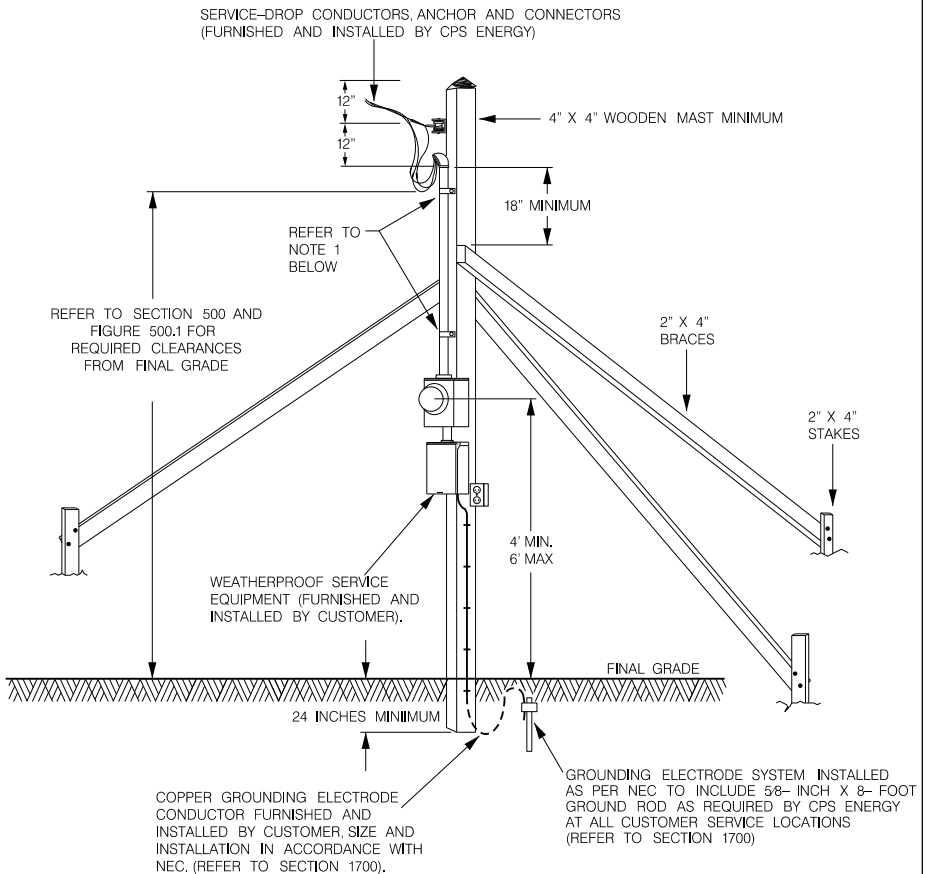

NOTES:

1. SERVICE RACEWAY SHALL BE SUPPORTED WITH 2- HOLE STRAPS ATTACHED WITH SCREWS AND INSTALLED WITHIN 6 - 12 INCHES OF SERVICE HEAD AND OF METER ENCLOSURE.
2. 125- AMPERE METER SOCKET WITH 1 1/4- INCH HUB FURNISHED, INSTALLED AND WIRED BY CUSTOMER. REFER TO FIGURE 1800.1.
3. SERVICE RACEWAY SHALL BE FURNISHED AND INSTALLED BY CUSTOMER. RACEWAY SHALL BE EMT, RMC OR IMC. MINIMUM SIZE OF SERVICE RACEWAY IS 1 1/4 INCH.
4. CUSTOMER SHALL CONSTRUCT THE TEMPORARY SERVICE INSTALLATION AS SHOWN ABOVE AND MAINTAIN IT IN A SAFE CONDITION THROUGHOUT ITS PERIOD OF USE. CPS ENERGY RESERVES THE RIGHT TO DISCONNECT DAMAGED OR UNSAFE T.M.S.
5. THE TEMPORARY SERVICE INSTALLATION MUST BE IDENTIFIED WITH A PROPER SERVICE ADDRESS BEFORE CPS ENERGY WILL CONNECT AND INSTALL A METER.
6. WHERE TEMPORARY THREE-PHASE SERVICES ARE REQUESTED, A CUSTOMER-OWNED METER POLE IN ACCORDANCE WITH SECTION 1400 SHALL BE INSTALLED FOR OVERHEAD SERVICES AND WHERE SUPPLIED FROM AN OVERHEAD TO UNDERGROUND OR UNDERGROUND SERVICE, THEN CUSTOMER SHALL BE REQUIRED TO CONSTRUCT A METERING EQUIPMENT RACK IN ACCORDANCE WITH FIGURE 1800.20.

SECTION 1700

GROUNDING OF SERVICES



1701 General:

The purpose of this Section is to summarize practical methods of grounding from the National Electrical Code (NEC) and the National Electrical Safety Code (NECS) as one of the means of safeguarding employees and the public from injury that may be caused by electrical potential.

Note 1: *Sound engineering standards and policies developed by CPS Energy along with the National Electric Safety Code (NECS) are used for grounding and bonding the electric distribution system by CPS Energy.*

Note 2: *CPS Energy shall make all grounding and bonding connections on supply facilities under the exclusive control of CPS Energy unless otherwise specified by CPS Energy.*

1702 Services Supplied by CPS Energy:

Each service supplied by CPS Energy shall be grounded and connected to earth by Customer in accordance with the provisions of the NEC and other applicable codes. The connection to earth shall be in a manner that will limit the voltage imposed by lightning, line surges or unintentional contact with higher voltage lines and that will stabilize the voltage to earth during normal operation.

Note: *For the purpose of this section, where a main disconnect is installed ahead of grouped CPS Energy meters, the Customer disconnects on the load-side of meters shall be considered service disconnects and the conductors supplying them shall be considered service conductors.*

1703 Grounded (Neutral) Conductor Brought To Service Equipment:

Where an AC system operates at less than 1000 volts and is supplied by CPS Energy as a grounded system, the grounded conductor shall be run to each service disconnecting means. The grounded conductor shall be connected to each service disconnecting means grounded conductor terminal or bus. A main bonding jumper shall connect the grounded conductor to the service disconnecting means enclosure.

1704 Grounding Electrode System:

As part of the grounding electrode system, a ground rod electrode shall be furnished and installed by Customer at each service location. This ground rod electrode shall be in addition to other electrodes that are required to be used to comprise the grounding electrode system. The grounding electrodes and grounding electrode system shall be installed in accordance with the NEC and other applicable codes including the provisions herein (Refer to Figure 1700.1).

Note: *CPS Energy does not permit bonding or grounding connections of any kind to line-side gas piping of gas meters.*

1704.1 Ground Rod Electrodes:

Ground rods shall be 5/8 inches by 8 feet and consist of a steel core with a molten welded exterior layer of pure copper. CPS Energy does not permit the use of aluminum electrodes or electrodes made of pipe or conduit.

Rods shall be driven vertically their entire length. Where encountering rock, ground rods may be driven at an angle of 45 degrees from the vertical

or shall be buried in a trench that is not less than 30 inches deep (Refer to Figure 1700.1).

1704.2 Grounding Electrode Conductor:

The NEC and other applicable codes shall determine the size of the grounding electrode conductor, but in no case shall it be smaller than No. 8 AWG copper. The grounding electrode conductor shall be in accordance with (1) through (3) below:

- (1) Conductor shall be copper (aluminum or copper-clad wire is not acceptable).
- (2) Bare copper grounding electrode conductors shall not be in aluminum conduit unless suitably coated or plated to resist corrosion.
- (3) Grounding electrode conductors shall be protected where subjected to physical damage in accordance with the NEC.

(A) Attachment to Electrode:

The grounding electrode conductor shall be attached to the ground rod electrode by means of an approved high strength corrosion resistant copper alloy clamp. Water pipe type clamps shall not be used on ground rod electrodes.

Metal raceways for grounding electrode conductors shall be electrically continuous from the point of attachment to cabinets or equipment without splice or joint to the grounding electrode, and shall be securely fastened (or bonded) to the ground clamp or fitting as per NEC.

(B) Attachment to Service Equipment:

Customer's grounding electrode conductor may be connected to the grounded conductor of the wiring system at any convenient point on the supply side of their service disconnecting means, except it shall not be terminated in or routed through meter sockets, meter disconnects or CT enclosures.

Where a main disconnect is installed ahead of grouped meters, the connection to the grounding electrode conductor shall be made in that device. Where no main disconnect is required, the connection may be made within an auxiliary wire or step-buss gutter.

1705 Customer's Equipment Grounding Conductor:

Customer's equipment grounding conductors shall be sized and installed in accordance with the NEC and other applicable codes. Equipment grounding conductors shall not be terminated or routed through meter sockets, meter enclosures, meter disconnects, instrument transformer enclosures or CPS Energy transformers.

Exception: Photovoltaic (PV) meter sockets on load-side of Customer's service equipment may have equipment grounding conductor terminated within.

1706 Bonding of Service Equipment:

The normally non-current carrying metal parts of equipment indicated in (1) and (2) below shall be bonded together:

- (1) All raceways, cable trays, cable bus framework, auxiliary gutters or service cable armor or sheaths that enclose, contain or support service conductors.
- (2) All enclosures containing service conductors, including metering equipment, boxes, or the like, introduced in the service raceway or armor.

1706.1 Method of Bonding at the Service:

Bonding jumpers meeting the requirements of the NEC shall be used around impaired connections, such as reducing washers or oversized, concentric, or eccentric knockouts. Standard locknuts or bushings shall not be the only means for the bonding required by this section but shall be permitted to be installed to make a mechanical connection of the raceway(s).

Electrical continuity at service equipment, service raceways, and other service conductor enclosures shall be ensured by one of the following methods:

- (1) Bonding equipment to the grounded service conductor in a manner permitted by the NEC.
- (2) Connections utilizing threaded couplings or threaded hubs on enclosures where made up wrench tight.
- (3) Threadless couplings and connectors where made up wrench-tight for metal raceways.
- (4) Other listed devices, such as bonding type locknuts, bushings, or bushings with bonding jumpers.

Exception 1: *CPS Energy requires the bonding of single-position, self-contained meter sockets in accordance with method (1) described above.*

Exception 2: *On all other metering and instrument transformer enclosures, Customer shall be responsible for this bonding requirement, but shall not use bushings or other listed devices that utilize bonding jumpers for accomplishing the required bonding of this equipment.*

1707 Bonding for Other Systems (Intersystem Bonding):

The intersystem bonding termination for connecting intersystem bonding and grounding conductors required for other systems such as cable TV, telephone, etc. shall be provided external to enclosures at the service equipment and at the disconnecting means for any additional buildings or structures.

Exception: *Such termination devices "shall not" be installed in or on any metering or instrument transformer enclosures.*

1708 Grounding of CPS Energy Service Drops and Laterals:

CPS Energy will ground its service drops and service laterals at the source of supply. This ground shall not serve as Customer's grounding source. On overhead or underground services, Customer shall not extend their equipment grounding conductor back to the source of supply (CPS Energy transformer terminals).

FIGURE 1700.1
TYPICAL GROUNDING ELECTRODE SYSTEM FOR SINGLE-PHASE OVERHEAD SERVICE

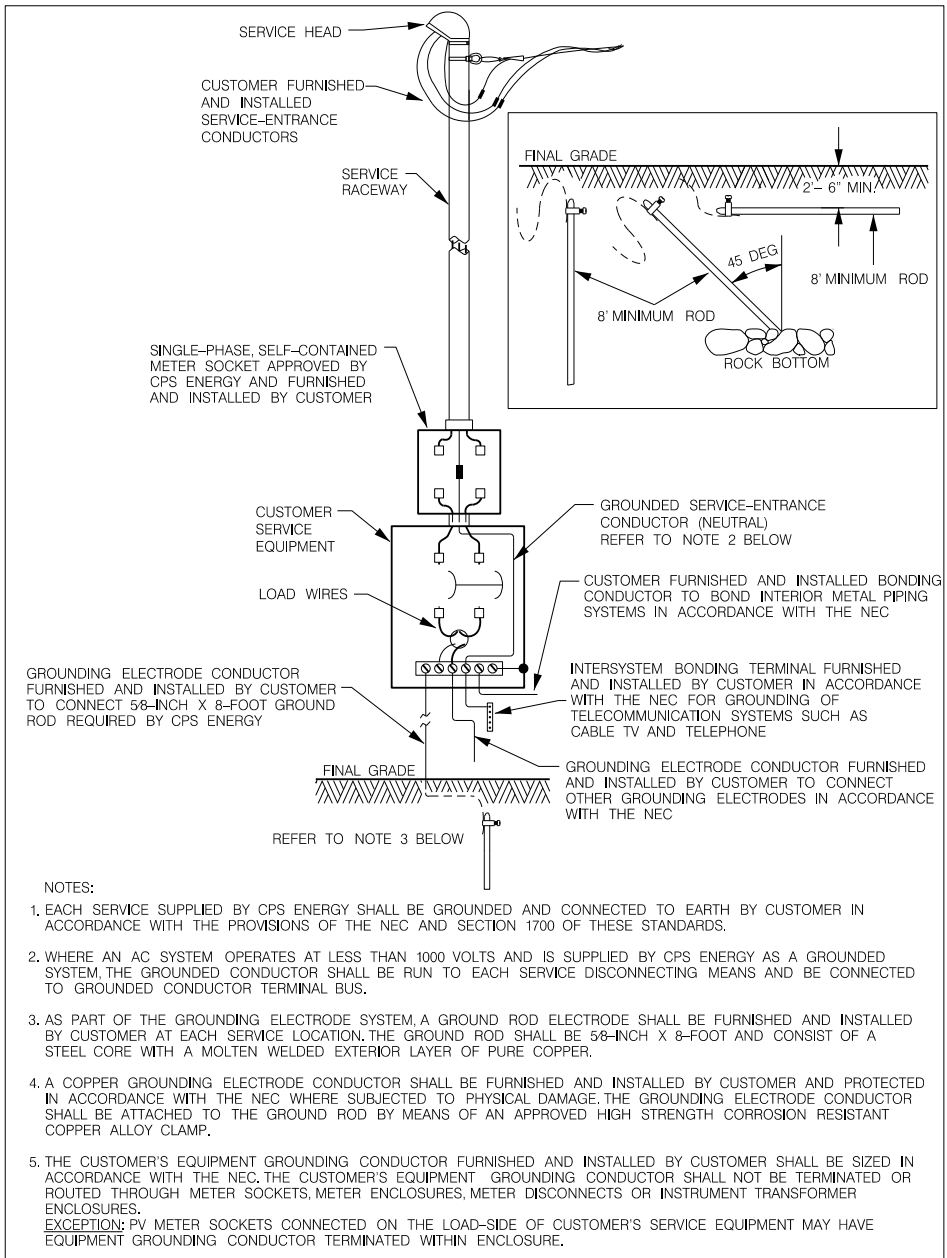

SECTION 1800

**METERING EQUIPMENT AND
ITS INSTALLATION**

METERING EQUIPMENT AND ITS INSTALLATION



1801 General:

This section will cover the application process and general installation requirements for metering equipment to include: self-contained and transformer rated meter sockets, current transformers (CT's), voltage transformers (VT's), primary metering cabinets, transockets, meter pedestals, modular metering equipment, meter disconnects, necessary enclosures, and associated support equipment as required by CPS Energy.

1801.1 Metering Equipment Space Allocation:

Customer shall allocate adequate space on the building to accommodate metering and service equipment. Customer will be responsible to assure that all subsequent work performed by contractors is installed in properly allocated spaces and in overall accordance with initial design.

1801.2 Unauthorized Handling of Metering Equipment:

Unauthorized personnel shall not handle CPS Energy metering equipment, possess seals, or break seals. Only CPS Energy personnel will handle, install, remove, rearrange, and seal/unseal electric metering equipment.

***Exception 1:** CPS Energy may authorize Customer to install instrument transformers in pre-approved enclosures/meter compartments.*

***Exception 2:** When gutters, etc. are opened or unsealed by CPS Energy for Customer work, Customer is responsible for providing a one-time lock to safely secure meter covers, gutters, etc. (Refer to Article 1808.7).*

CPS Energy will remove one-time lock and inspect all work before installing approved lock and/or seal.

1802 Applications:

Customer requesting an electric service from CPS Energy shall first complete the appropriate application. The Customer may request assistance from the CPS Energy Customer Service Representative (Refer to "Helpful Numbers" listed on the inside front cover page).

1802.1 Permits Required by Authority Having Jurisdiction (AHJ):

Customer shall obtain permits as required by the AHJ of the respective jurisdiction before CPS Energy will release metering equipment.

1802.2 Customer Request for Metering Equipment

Requests for metering equipment shall be made to the CPS Energy Customer Service Representative. An internal "CABINET REQUEST" work order will then be initiated and a work request number assigned. Applicant must furnish the following data:

- (1) Electrical contractor's name and telephone number.
- (2) Street and legal address(es) for the job site.
- (3) Electrical permit number if applicable.
- (4) Class of service such as residential or commercial.

- (5) Type of job such as new construction, remodeling or adding load, with amount of added load given.
- (6) Single-phase or three-phase.
- (7) Service voltage.
- (8) Switch or circuit breaker ampere rating for each meter.
- (9) Wire size and type in meter socket or CT enclosure.
- (10) Service type, e.g. Overhead Service Drop, Underground from Overhead System, Padmount Transformer, etc.

1802.3 Work Request Number Assigned:

Customer will receive a Work Request number that shall be used when requesting the status of the meter cabinet order. For CPS Energy issued metering equipment, CPS Energy will release the Work Request for all residential or commercial metering equipment only after the CPS Energy Customer Service Representative has received an approved meter loop drawing and verified that an electrical permit has been issued by the AHJ, where applicable.

1802.4 Equipment Pick Up:

Customer must pick up CPS Energy issued metering equipment at the CPS Energy facility located at 511 S. Salado St. between the hours of 8:00 AM to 11:00 AM and 12:00 PM to 2:00 PM Monday through Friday. Customer must, before CPS Energy issues material, be prepared to furnish the necessary work request number and present personal identification.

Note: Where metering equipment is issued by CPS Energy, the meter sockets and enclosures for 'one meter' installations will be issued on the same job.

1803 CPS Energy Furnished Metering Equipment and General Installation Requirements:

On all commercial installations CPS Energy will furnish necessary metering equipment to include self-contained and transformer rated equipment. On residential installations, CPS Energy will furnish instrument transformer rated metering equipment as required.

CPS Energy will furnish the standard metering equipment outlined in Table 1800.1 and Figure 1800.1 for commercial applications. This article covers typical applications of this metering equipment along with their general installation requirements.

Note: Customer shall be responsible for furnishing and installing residential single-phase, self-contained meter sockets. CPS Energy does not furnish this metering equipment. The general installation requirements outlined herein for self-contained meter sockets shall be applicable.

1803.1 Single-Position, Self-Contained, Meter Sockets:

Single-position, self-contained, meter sockets furnished by CPS Energy can be used for overhead and/or underground service installations.

Where Customer calculated loads exceed the load limitations outlined in Table 1800.2, or when Customer service-entrance conductor size exceeds the meter

socket specifications, Customer will be required to design their service to use transformer rated metering equipment as outlined in this Section.

(A) Overhead and Underground Service Installations:

Single-position, self-contained, meter sockets furnished by CPS Energy are designed to be used with either overhead or underground services.

These type sockets may also be used in multiple (grouped) metering schemes where sockets are installed below auxiliary (meter) gutters. Sockets shall not be installed both above and below the same auxiliary (meter) gutter (Refer to Figures 1800.5 and 1800.9).

Note: The meter socket issued by CPS Energy will be based on the load to be metered and the service-entrance conductor size (Refer to Table 1800.2 for calculated load limitations).

(B) Conductor Size Limitations:

Conductor sizes permitted in self-contained meter sockets shall be as outlined in Figures 1800.1 and 1800.2

Where Customer is responsible for furnishing and installing both line and load conductors within a meter socket, conductors shall be sized the same and must be of the same material and ampacity rating.

(C) Wiring of Single-Position, Self-Contained Meter Sockets:

Customer shall furnish and terminate all conductors within single-position, self-contained meter sockets.

Exception No. 1: Where CPS Energy service lateral conductors enter a meter socket, CPS Energy will make the terminations of these conductors.

Exception No. 2: Where 5th terminals are required on three-wire 120/208-volt meters, CPS Energy will make the necessary terminations on the 5th terminal (Refer to Figure 1800.5).

Note: In no case will Customer be authorized to bypass a meter socket or other metering equipment to provide unmetered service.

(1) Conductor Identification:

Customer line and load conductors must be identified at their terminations in accordance with Section 400 of these Standards. Terminals so identified will be evidence of Customer's intended phase sequence, "hi-leg" position, plus position of other phase conductors and the neutral conductor. Meter loops lacking proper conductor identification will not receive a CPS Energy meter. Customer assumes all responsibility for conductors that are improperly identified or terminated.

- (a) Particular attention must be paid to identification and placement of the "hi-leg" conductor in sockets being wired for 240Δ/120-volt, 4-wire services (Refer to Figure 1800.8). The "hi-leg" conductor has 208 volts to neutral and shall, for proper metering equipment operation, be in the farthest right-hand position (C-phase position) facing the meter socket; however, NEC rules require that the "hi-leg" conductor occupy a center position in Customer's service equipment and be identified as "B" phase.

- (b) The "hi-leg" conductor must be identified orange in color. CPS Energy may, for its operations, identify the "hi-leg" at its transformer, service, or other location as a phase other than "B".

(2) Line and Load Conductors and Connections:

All meter sockets must have the line-side (source) conductors connected to their top terminals. Load-side conductors must connect to the bottom terminals of the meter socket. Refer to Figures 1800.3 through 1800.9 for proper conductor terminations in standard, single-position, self-contained meter sockets.

Exception: Photovoltaic (PV) meter sockets shall have conductors from the solar installation side connected to the top terminals as the solar production becomes the "source" (the PV meter is a non-billing relevant meter).

- (a) Meter socket terminals are designed to accept either copper or aluminum conductors, but where aluminum conductors are installed, wire ends must be wire brush cleaned and have grit filled joint compound applied to them and the terminals before terminal screws are made tight.
- (b) Customer must observe the terminal screw torque requirements that are labeled in each socket. Poor connections may be the result if the recommended torque is either reduced or exceeded.
- (c) No more than one conductor per phase or neutral shall be terminated within a meter socket with the exception of the Code 31 and Code 32 meter sockets.
- (d) Conductors formed within the socket's enclosure must not be allowed to rest on or press against other terminals.
- (e) Where metering equipment is connected using paralleled conductors, such conductors shall be installed in individual raceways and in the same manner on both line and load of equipment.

1803.2 Instrument Transformer Rated Metering Equipment:

Instrument transformer rated metering equipment is installed when either the Customer's calculated load or service-entrance conductor size exceed the maximum ratings/specifications of single-position, self-contained meter sockets. CPS Energy furnishes the standard instrument transformer rated metering equipment outlined in Table 1800.1 of this Section. There are various methods of installing instrument transformer rated metering equipment that depend on the service voltage, type of service, etc. This article covers typical applications of this type of metering equipment along with its general installation requirements.

Instrument transformer rated metering and enclosures may be installed outdoors, in a standard weatherproof enclosure, in a switchboard or switchgear, or within the secondary compartment of CPS Energy's padmount transformer. All jobs requiring instrument transformers must be closely coordinated with CPS Energy's Customer Service Representative.

(A) Customer's Calculated Load and Service Conductor Criteria:

The use of instrument transformer rated metering equipment will be determined by CPS Energy and will depend on the calculated load to be supplied and the service conductors to be installed. Customer shall determine calculated load and service conductor sizes in accordance with the NEC (Refer to Definition of "Calculated Load").

Where Customer's calculated load exceeds the values outlined in Table 1800.2, instrument transformer rated metering equipment must be installed.

Where Customer's service conductor size exceeds the maximum allowable specifications outlined in Figure 1800.1 or Figure 1800.2 for self-contained meter sockets, instrument transformer rated metering equipment must be installed.

(B) Instrument Transformers (Current Transformers/Voltage Transformers):

CPS Energy furnishes and installs the necessary current transformers (CT's) and voltage transformers (VT's) that are required for service installations. CPS Energy also furnishes and installs the metering control cables from the instrument transformers to the transformer rated meter socket. Most CT's are window type (donut-type), with the service conductor passing through the CT opening and serving as the primary winding (Refer to Definition of "Instrument Transformer" and Figure 1800.13).

Exception: *Customer installs instrument transformers where they are to be installed within Customer furnished metering enclosures, switchgear, or switchboard or in other cases where directed by CPS Energy.*

(C) Standard Instrument Transformer Enclosures:

CPS Energy furnishes the following standard weatherproof instrument transformer enclosures for installation by the Customer. CPS Energy will work with electrical contractor on installation of instrument transformers so as to facilitate the installation of service conductors and eliminate unnecessary splices within enclosure (Refer to Table 1800.1 and Figure 1800.11).

- (1) Code 10, 26 inches (H) x 30 inches (W) x 9 inches (D), for 2-250 KCM/Phase or equivalent KCM in fewer conductors.
- (2) Code 11, 50 inches (H) x 32 inches (W) x 14 inches (D), for 3-500 KCM/Phase or equivalent KCM in fewer conductors.
- (3) Code 12, 60 inches (H) x 48 inches (W) x 14 inches (D), for 4-750 KCM/Phase or equivalent KCM in fewer conductors.

Note 1: *The total KCM value of the service conductors listed for any enclosure above shall not be exceeded.*

Note 2: *Code 12 enclosure may be adapted for busbar installations, but busbars shall not have an ampacity larger than 2000 amperes or a width greater than 4 inches. All designs shall be submitted to CPS Energy for approval before installation.*

Note 3: *Where Customer's service design requires the use of a larger instrument transformer enclosure than those furnished by CPS Energy, Customer*

shall submit to CPS Energy for approval, an enclosure meeting CPS Energy's specifications and construction criteria.

(D) Standard Transockets:

Transockets are self-contained, weatherproof metering enclosures that house all required instrument transformers, test switch, metering control cable, and meter socket. CPS Energy will utilize demand diversification to Customer's calculated loads when sizing transockets. Transockets may accommodate estimated demand loads up to 800 amperes and service conductor sizes up to 2-500 KCM cables per phase.

Standard instrument transformer enclosures may be installed on an exception basis for estimated demand loads of 800 amps or less if requested by Customer. CPS Energy furnishes the following standard transocket enclosures for installation by the Customer:

<u>Type of Transocket</u>	<u>Maximum Demand Load</u>
Code 23, Overhead (400 Amperes),	(144 kVA, 208V) (333 kVA, 480V)
Code 24, Overhead (800 Amperes),	(288 kVA, 208V) (665 kVA, 480V)
Code 25, Underground (400 Amperes),	(144 kVA, 208V) (333 kVA, 480V)
Code 26, Underground (800 Amperes),	(288 kVA, 208V) (665 kVA, 480V)

It is critical that the correct transocket be installed for each service installation due to the pre-wired configuration of internal equipment. Where service is underground, the line conductors must enter the bottom of the transocket and connect to the bottom terminals. Where service is overhead, the line conductors will enter the top of the transocket and connect to the top terminals. Load conductors will always exit opposite the line conductors and conductors will not be allowed to cross inside the transocket. The conductor entrance/exit location notes must be followed (Refer to Table 1800.1 and Figures 1800.18 and 1800.19 for more specific and detailed information related to transockets).

(E) Customer Furnished and Maintained Service Conductors through CT's:

On metering installations where Customer furnishes all service conductors in instrument transformer enclosures, they shall coordinate with CPS Energy and pull their conductors through the window type CT's to their service equipment thereby avoiding connections.

(F) CPS Energy Furnished and Maintained Service Conductors through CT's:

On overhead to underground services, CPS Energy will furnish the line-side conductors. All connections must be made in the instrument transformer enclosure to establish the point of delivery (POD) (Refer to Figure 1800.13).

- (1) Where cable-to-cable connections are required, they shall be made on the load-side of window type CT's. Where aluminum service conductors are used, Customer shall furnish compression type connectors with compression tool for installation. Where copper service conductors are used, Customer shall furnish heavy duty pre-insulated connectors. The Customer will install the connectors on their service conductors and CPS

Energy will make the connection to the CPS Energy service cables. This junction then will be the POD.

(G) Location of Instrument Transformers and Enclosures:

(1) One Meter Installations:

- (a) For overhead service drops, donut type CT's/VT's will be furnished and installed by CPS Energy on a transformer mounting bracket (TMB) mounted on a service mast, meter pole or on the building or structure. Where they must be installed on building wall or structure, Customer shall install TMB's for CPS Energy. CT's/VT's will be placed on the TMB's where the service drop is installed by CPS Energy (Refer to Figures 500.5, 500.6, 500.7, and 1400.2).
- (b) When deemed necessary by CPS Energy, for overhead service drops the CT's/VT's will be installed by Customer within an enclosure furnished by CPS Energy. Enclosure may be mounted on a meter pole with a meter rack (Refer to Figure 1400.2) or directly on the building or structure (Refer to Figures 1800.11 and 1800.13).
- (c) For overhead to underground service, the CT's/VT's will be installed by Customer within an enclosure furnished by CPS Energy. Enclosure may be located on a metering equipment rack or directly on the building or structure (Refer to Figures 700.1, 1800.13 and 1800.20).
- (d) For services supplied by padmount transformers, the CT's/VT's will be located within the secondary compartment of the transformer (Refer to Figures 1000.1 and 1000.2 and Section 1000).
- (e) *Exception: On transformer installations of 300 kVA or less, CPS Energy may require the use of self-contained metering equipment on a metering equipment rack or directly on the building or structure.*
- (f) For overhead primary voltage service, the CT's/VT's will be installed on a CPS Energy owned primary meter pole (Refer to Section 1200).
- (g) For underground primary voltage service, the CT's/VT's may be located within Customer's switchgear or switchboard, or they may be located within an outdoor primary metering padmount cabinet. CPS Energy will furnish this enclosure at Customer's expense (Refer to Section 1300).
- (h) For services supplied from the Downtown Network System, CT's/VT's, will either be installed within a CPS Energy furnished instrument transformer enclosure or may be installed within a compartment specifically designed and isolated for metering equipment in Customer's switchgear or switchboard. Where CT's/VT's are to be installed in an instrument transformer enclosure, the enclosure shall be installed by Customer (Refer to Section 1100).

Exception: Where Customer's service design requires the use of a larger instrument transformer enclosure than those furnished by CPS Energy, Customer shall submit to CPS Energy for approval, an enclosure meeting CPS Energy's specifications and construction criteria.

(2) Multiple Meter Installations:

On multiple meter installations where CPS Energy instrument transformers are required in accordance with this Section, a standard instrument transformer enclosure furnished by CPS Energy will be installed by Customer on an auxiliary meter gutter.

Exception: Code 12 enclosures are not permitted to be installed directly above an auxiliary gutter.

(H) Instrument Transformer Rated Meter Sockets:

CPS Energy furnishes all transformer rated meter sockets and meters. Customer shall be responsible for installing meter sockets and the conduits necessary for the metering control cable between the meter sockets and the instrument transformer enclosures/compartments (Refer to Figure 1800.12).

(I) Primary Metering Padmount Cabinets:

CPS Energy furnishes this equipment at Customers expense (Refer to Section 1300).

1804 Customer Furnished Metering Equipment and General Installation Requirements:

This article will cover the different types of metering equipment that must be furnished and installed by Customer for use on single-phase and three-phase services. This equipment includes: 125, 200, and 320-ampere, single-phase, self-contained meter sockets, modular metering equipment, meter pedestals, free-standing metering equipment racks, and where necessary custom made instrument transformer enclosures including isolated and dedicated compartments within Customer's switchgear. General installation guidelines for this equipment are also covered in this article.

1804.1 Single-Phase, Self-Contained Meter Sockets for Residential Installations:

CPS Energy approved single-phase, self-contained meter sockets are rated at 125, 200, and 320 amperes. These sockets can be purchased by Customer at local electrical distributors or major retail hardware stores. Approved meter sockets will be identified by the CPSB stamp on the inside of socket and embossed CPSB lettering on the lower right-hand corner of the lid. Customer shall use this type of meter socket in all cases where single-phase service is supplied from CPS Energy and/or where single-phase supply is to be taken from a three-phase service. These types of meter sockets are limited to maximum calculated loads of 320 amperes (Refer to Figure 1800.1).

Note 1: All installation and wiring requirements outlined in Article 1803.1 for these types of sockets shall be applicable.

Note 2: CPS Energy furnishes single-phase self-contained sockets for commercial installations.

1804.2 Modular Metering Equipment:

Modular metering equipment consists of factory made, pre-bussed meter centers with main breaker compartments, single-position meter sockets, and individual breakers all designed to be field assembled in modular fashion. Modular metering equipment may be used after approval from CPS Energy's Electric Service and Metering Standards Section for use on multifamily dwellings

requiring 120/240-volts and/or 120/208-volts for calculated loads not exceeding 200 amperes per individual unit or house load (Refer to Figure 1800.14).

Note: *House loads exceeding 200 amperes shall have dedicated transformer rated metering equipment and shall be grouped with respective building modular metering.*

(1) Uses Not Permitted:

CPS Energy will not approve or accept modular metering equipment for commercial single-phase or three-phase applications except for cell tower sites requiring single-phase, 120/208-volts from a 208Y/120-volt three-phase service. CPS Energy neither owns nor maintains modular metering equipment. Modular metering also is not permitted where:

- (a) Service voltage is 480Y/277-volt.
- (b) Customer calculated load greater than 200 amperes is projected for any one meter (large loads must be separated in the planning stages).
- (c) Single-phase loads cannot be balanced on 208Y/120-volt services.
- (d) Modular metering equipment is not owned by one party who is responsible for its maintenance.

(2) General Requirements of Modular Metering Equipment:

Modular metering equipment must be manufactured in accordance with all applicable national standards and shall be listed. All modular metering equipment shall have written approval by CPS Energy's Electric Service and Metering Standards Section prior to making purchase. Specific requirements by CPS Energy for modular metering equipment are as follows:

- (a) Equipment must have a fault current rating exceeding fault current available at the particular installation location.
- (b) Covers on circuit breaker compartments must be removable without disturbing meters.
- (c) Non-removable durable covers must enclose unmetered incoming main bus. Metered and unmetered busbars within the metering compartments shall not be in close proximity to one another unless they are protected against tampering.
- (d) Meter socket components must be readily accessible and removable for maintenance. Spare parts must be readily available.
- (e) Meter sockets shall have bypass horns and meter guides.
- (f) Meter lids shall be ringless type and when removed shall not require removal of other lids or in any way interfere with the operation of adjacent meters.
- (g) Where 120/208-volt, three-wire, meters are required, the modular metering stacks must be equipped to receive 208Y/120-volt, four-wire

service for load balancing purposes, and they must have movable internal bus connectors to accomplish the balancing. A fifth terminal is required in each meter socket and it must be in the 9 o'clock position facing the socket. Each fifth terminal must have a connection to the neutral bus.

- (h) Single-phase 125-ampere meters must not be stacked higher than five meters, single-phase 200-ampere meters must not be stacked higher than four meters (Refer to Figure 1800.14).
- (i) Where a line-side (source) or main lug only (MLO) (required for two to six meters) is used to receive the service, its cover must have a provision for a CPS Energy padlock. Where end-bells cover bus extension outlets, the end-bells must have a provision for wire seals or be sealed with fasteners that are not externally removable. Where a main disconnect module is used; its cover must have a provision for a standard one-time padlock type seal.
- (j) Individual circuit breakers at tenant meters are required and must have independent lockable covers.

1804.3 Meter Pedestals with Single Position Meter Sockets:

A meter pedestal is a freestanding device consisting of a vertically mounted channel that supports the meter socket and service equipment, both integral to the meter pedestal. The meter pedestal may be pre-bussed, and its general design is similar to modular metering equipment described in this section. A meter pedestal may be used where approved by CPS Energy's Electric Service and Metering Standards Section (Refer to Definition of "Meter Pedestal" and Figure 1500.1).

(1) Uses Not Permitted:

CPS Energy neither owns nor maintains meter pedestal equipment. Meter pedestal equipment is not permitted where:

- (a) Three-phase service is requested.
- (b) Service voltage is 277/480-volts.
- (c) Customer calculated load greater than 200 amperes is projected for any one meter socket.
- (d) Meter pedestal is not owned by one party who is responsible for its maintenance.
- (e) There is more than one meter socket per pedestal.

(2) General Requirements of Meter Pedestal Equipment:

Meter pedestals must be manufactured in accordance with all national standards for such devices and be listed. Specific requirements by CPS Energy are as follows:

- (a) Equipment must have a fault current rating exceeding fault current available at the particular installation location.
- (b) Meter sockets must be 200 amperes rated.

SECTION 1800 - METERING EQUIPMENT AND ITS INSTALLATION

- (c) Meter socket components must be readily accessible and removable for maintenance. Spare parts must be readily available.
- (d) Meter sockets shall have bypass horns and meter guides.
- (e) Meter lids shall be ringless type and when removed shall not require removal of other lids or in any way interfere with the operation of adjacent meters.
- (f) Meter pedestals may be padmount or have an underground concrete encased mounting support. Underground portions must have sufficient strength to support the unit and be coated or otherwise protected to prevent corrosion. The underground portion shall be made rigid by pouring a minimum 20-inch thick by 18-inch diameter concrete base around the unit's stabilizing footing or other extension. Other than the footings, no part of the meter pedestal shall be installed in direct contact with the earth (Refer to Figure 1500.1).
- (g) Customer must install a 3-inch minimum schedule 40 PVC conduit and a 24-inch radius elbow at the base of the unit. The conduit shall extend 6 inches above the concrete base into the service lateral terminating compartment. The elbow shall be encased in the concrete base and extend approximately 6 inches beyond the concrete base at a depth of 24 inches below final grade.
- (h) For residential applications, the end of the elbow that extends out of the concrete base shall be plugged and face in the direction specified by the CPS Energy Representative. CPS Energy shall install trench from source to meter pedestal and furnish and install the service lateral conduit.
- (i) For commercial applications, Customer shall install trench, elbow, and service lateral conduit from source to meter pedestal in accordance with requirements specified by the CPS Energy Customer Service Representative.
- (j) The service lateral conductors furnished and installed by CPS Energy, will enter the pedestal's terminal compartment via the 3-inch conduit elbow and will be terminated by CPS Energy with Customer furnished CPS Energy approved lugs. The lugs in the terminal compartment must accommodate copper or aluminum conductors that will normally be in sizes of No. 2 AWG through No. 4/0 AWG. Lugs must be mounted on terminals that are supported by an insulating terminal block or equivalent arrangement. A pass through type bonding lug must also be provided in the terminal compartment.
- (k) Customer shall furnish and install an approved grounding electrode at each pedestal in accordance with the NEC and Section 1700. Grounding electrodes shall not be installed within meter pedestal housing.
- (l) Load-side conduit shall not be installed within the same compartment used for CPS Energy's service lateral conductors.

1804.4 Metering Equipment Rack (Meter Rack):

Customer may furnish and install a free-standing metering equipment rack that is built in accordance with CPS Energy specifications. Customer must obtain approval from CPS Energy for the metering equipment rack design prior to installation.

Submittal of meter rack design to CPS Energy for approval must include all metering and service equipment to be installed and size and rating of service equipment. Size of service conductors and calculated load information shall also be submitted for review (Refer to Definition of "Metering Equipment Rack" and Figure 1800.20 for general requirements).

Note: Stand-alone metering equipment racks are not permitted to support service drops. A meter pole installed in accordance with Section 1400 will be required (Refer to Figure 1400.1)

1804.5 Metering Instrument Transformer Compartment within Customer Switchgear:

Customer may furnish and install a dedicated and isolated metering instrument transformer compartment within their switchgear to house the metering instrument transformers. Metering instrument transformer compartment shall be in accordance with CPS Energy specifications listed within this article. Customer must obtain approval from CPS Energy for the metering instrument transformer compartment design prior to ordering.

Submittal of the metering instrument transformer compartment design shall include, but not limited to:

- (a) Manufacturer's switchgear specification sheet.
- (b) Switchgear rating in amperes.
- (c) Metering instrument transformer compartment dimensions.
- (d) Mounting provisions for metering instrument transformers.
- (e) One-line electrical diagram.
- (f) Size of switchgear bus/conductors.
- (g) Engineer's calculated load information.

(1) Customer Owned Equipment Not Permitted within Metering Instrument Transformer Compartment:

Customer owned relays, meters, instruments, instrument transformers or other equipment including Customer owned wiring shall not be installed in metering instrument transformer compartment or its panels or doors. Customer owned equipment or devices will not be permitted to be supplied from or be wired to the metering circuit or be accessed through the metering instrument transformer compartment.

(2) Installation of CPS Energy Transformer Rated Meter Socket and Conduit:

CPS Energy's transformer rated meter socket will be furnished by CPS Energy and installed by Customer external to the switchgear or switchboard. The meter socket must be located within 20 feet of the metering instrument

transformer compartment and shall not be mounted on the switchgear or switchboard (Refer to Figure 1800.12).

- (a) On indoor switchgear or switchboard, Customer may exit metering instrument transformer compartment with either above ground or underground conduit to meter socket. For above ground conduit installation, Customer may furnish and install a continuous, except for approved couplings, 1 1/4-inch rigid metal conduit (RMC) or intermediate metal conduit (IMC) from the metering instrument transformer compartment to the meter socket. For underground installations, Customer must furnish and install a 2-inch schedule 40 PVC conduit from the metering instrument transformer compartment to the meter socket. Conduit must exit through the slab and must have a minimum of 24 inches cover from final grade.
- (b) On outdoor switchgear, Customer may only exit the metering instrument transformer compartment with underground conduit to meter socket in accordance with the provisions for underground conduit in Article 1804.5 (2) (a).

(3) Metering Instrument Transformer Compartment Construction Specifications:

The Metering instrument transformer compartment must be located in a dedicated vertical compartment where the service conductors enter the switchgear or switchboard. Sufficient space in the Metering instrument transformer compartment shall be furnished to accommodate CT's/VT's, cable terminators, and stress cones where required. CPS Energy normally uses three CT's and when required, three VT's. Where practicable and when required, CT's and VT's may be in a common compartment, but on service voltages 600 volts and above the VT's must be in a separate isolated compartment located above or below the designated CT compartment.

- (a) For service voltage below 600 volts, the metering instrument transformer compartment's dimensions shall be a minimum of 30 inches (H) x 36 inches (W) x 18 inches (D) for 208Y/120-volt installations and a minimum of 42 inches (H) x 36 inches (W) x 18 inches (D) for 480Y/277-volt installations.
- (b) For service voltage above 600 volts, the metering instrument transformer compartment's dimensions shall be a minimum of 90 inches (H) x 48 inches (W) x 36 inches (D). Customer must furnish a pullout drawer or tilt-out trunnion arrangement to disconnect and effectively ground all VT primary (H1) terminals for the purposes of testing, inspection, and maintenance. Customer must maintain all Customer furnished equipment.

Exception: Service voltages of 34.5 kV will require Customer to coordinate with CPS Energy's Electric Service and Metering Standards Section prior to ordering or manufacturing of compartments due to special design considerations that need to be verified and approved by CPS Energy.

- (c) Metering instrument transformer compartment shall be constructed of same materials as switchgear cabinet to isolate the metering instrument transformer compartments from adjacent switchgear compartments. Access to the compartments through other switchgear compartments is prohibited.

- (d) Doors to the metering instrument transformer compartment(s) must be hinged type and be equipped with hasps or tongues for CPS Energy padlocks. All removable panels that may provide access to unmetereed circuits must be approved and lockable by CPS Energy.

(4) Installation of Metering Instrument Transformers within Customer Switchgear Compartment:

Metering instrument transformer description, ratio, catalog number and model numbers will be provided to Customer by CPS Energy. Customer must provide approved mounting provisions for metering instrument transformers. To facilitate construction of the metering instrument transformer compartment, CPS Energy will issue metering instrument transformers to the Customer for shipment to the switchgear fabricator. To do so, CPS Energy must receive at least 45 days advance written notice. Customer will be responsible for crating, shipment, insurance and providing CPS Energy Customer Service Representative with shipment tracking information. For service Voltage 600 Volt and below, Customer may also elect to install metering instrument transformers in the switchgear after delivery to job site in accordance with manufacturer specifications. It is the Customer's responsibility to ensure the proper fit of all metering instrument transformers. In all cases, Customer shall install the metering instrument transformers and tighten their busbars or connectors. CT's must be mounted with their primary polarity markings (white dot or H1 markings) facing the source side of the service.

- (a) Metering instrument transformers must be mounted at a height and depth to make them readily accessible from floor or slab level. Their centers may be no lower than 24 inches or higher than 72 inches from floor or slab level. Their depth must not prevent normal access from the front of the compartment. Their secondary terminal covers must be front accessible.
- (b) Voltage transformers (VT's) rated 600 volts may be mounted in the same compartment with CT's but they shall not be mounted near live busbars unless suitable insulating barriers isolate them. VT's shall be mounted on a side or bottom panel near the front of the compartment with fuse pull-out facing front opening of compartment. Customer shall ensure that VT's are tap to the line (source) side of CT's. Customer must provide taps on the busbars for VT connections. Tap connectors must be suitable for No. 12 AWG stranded copper wire. The neutral bus must pass through the metering instrument transformer compartment to accommodate the VT primary neutral connection.

Exception: *Where the neutral bar cannot pass through the metering compartment, manufacturer shall provide an insulated neutral bar capable of terminating two 6 AWG conductors.*

- (c) VT's rated above 600 volts shall have their primary (high voltage) terminals connected by Customer using suitably insulated cable. Connections must be made on the line-side of CT's. The neutral bus of the system must pass through the VT compartment to accommodate the VT primary neutral connection. VT's must have their H1 terminals connected via its disconnect/grounding devices to the three phases of the system. All H2 terminals will be bonded together and to the grounded neutral to form a ground wye system.

- (d) The secondary terminals (X1 and X2) of metering instrument transformers shall be connected to a suitable ten point terminal block furnished and installed by Customer. Terminal block must be accessible within the metering instrument transformer compartment and be located on the outside of the high voltage barrier but behind a lockable sealable door. The VT secondary wiring must allow for movement of the pullout drawer or trunnion. The ten point terminal block will contain voltage A-B-C-N and current A-B-C-N. All wiring from the metering instrument transformers to the terminal block shall be contained in the CPS Energy dedicated metering instrument transformer compartment of the switchgear. CPS Energy will install and connect the metering control cable from the CPS Energy meter to the ten point terminal block. CPS Energy will provide an electric metering wiring diagram for appropriate wiring/termination.
- (e) Where window type CT's are installed (typical for service voltage below 600 volts), Customer must provide a removable section of busbar for the opening of each CT. The CT window opening may vary from approximately 3 inches to 8 inches depending on its ampere rating. Customer's physical busbar size must be coordinated with CPS Energy's CT size.
- (f) Where cables, instead of busbars, are installed through the window type CT's, means shall be provided to disconnect the cables to facilitate replacement of CT's.
- (g) A ground bonding terminal capable of terminating two 6 AWG conductors shall be provided by the manufacturer.

1804.6 Other Types of Customer Furnished Instrument Transformer Enclosures (Custom Made):

Where Customer's service conductors exceed the maximum cable specifications for standard CPS Energy furnished instrument transformer enclosures, Customer shall furnish at their expense an enclosure for housing required instrument transformers. Enclosures shall be corrosion resistant, painted if steel, weatherproof where applicable, have removable covers which do not rely only on screws to secure them in position, be equipped with cover lifting handles as necessary for safety, and be constructed of minimum 12 gauge metal to prevent warping or bending. The enclosures must be sized in accordance with NEC and be equipped with padlock hasps or tongues and pentabolts. All custom made enclosures shall first be approved by CPS Energy's Electric Service and Metering Standards Section.

1805 Location of Metering Equipment:

Metering equipment shall be located outdoors in a readily accessible location. Where the metering equipment does not serve as the POD, it shall be located as close as possible to the POD. The metering equipment location in all cases shall either be designated or approved by CPS Energy's Customer Service Representative.

Exception 1: Metering equipment may be located on the inside of building for service designs supplied from the Downtown Network System in accordance with Section 1100.

Exception 2: Metering equipment for high-rise concept buildings may be grouped in dedicated meter rooms on various levels in accordance with Section 900.

Exception 3: *CPS Energy will review proposed designs where special circumstances may require the use of meter rooms within the building for location of multiple metering equipment. Where CPS Energy approves such designs, Customer shall be responsible for that portion of service conduits under the building or structure. Service conduits under the building or structure shall be installed as required to be considered outside of the building and shall terminate within 4 feet upon entering CPS Energy approved electric meter rooms. CPS Energy may require Customer to install spare conduits and to locate meter rooms on exterior walls as close as possible to transformer poles (Refer to Definition of "Conductors Considered Outside of Building").*

1805.1 Prohibited Locations:

Metering equipment shall not be installed in locations specified below:

- (1) Areas that may be enclosed in the future such as patios, covered porches, and/or carports.
- (2) Areas subject to vibration, fumes, corrosive vapors, etc.
- (3) Over ramps or stairways.
- (4) Extending over driveways or pedestrian sidewalks (unless specifically protected from accidental contact or physical damage).
- (5) Extending into narrow alleys or adjoining property (unless an easement is obtained).
- (6) Areas accessible only through trapdoors or hatches.
- (7) Areas accessible only by ladder.
- (8) On CPS Energy poles (except overhead primary meters).
- (9) On portable buildings or on manufactured homes or portable/temporary structures (Refer to Definition of "Portable").
- (10) Areas that expose personnel and/or metering equipment to potentially hazardous conditions.

1806 Heights of Metering Equipment:

Single-position, self-contained meter sockets and transformer rated meter sockets including transockets must be mounted so that the center of the meters will be not less than 4 feet or more than 6 feet above final grade or floor level.

Exception 1: *Where single position meter sockets are protected in meter rooms, basements or approved decorative meter enclosures, the minimum height may be reduced to 3 feet if pre-approved by CPS Energy's Customer Service Representative.*

Exception 2: *Where 480 volt self-contained meter sockets are supplied from an auxiliary bus gutter, the maximum height may be increased to 6 1/2 feet to accommodate installation of meter disconnects.*

Exception 3: Where four stack, and five stack modular metering is installed, the minimum height to the meter center of the lowest meter shall be to 3 feet and the maximum height to the center of the highest meter shall be 6 1/2 feet.
Note: Enclosures for housing instrument transformers must be mounted so that their tops will be no less than 6 feet or more than 6 1/2 feet above final grade or floor level (Refer to Figure 1800.11).

1807 Minimum Clearances and Working Space Required at Metering Equipment:
Metering equipment and associated service equipment shall be mounted in a location that provides minimum safe working clearances in accordance with the NEC and applicable codes and as specified below:

1807.1 Front Clearance:

There must be a minimum of 3 feet of unobstructed space in front of self-contained meter sockets, and 4 feet of unobstructed space in front of transformer rated meter sockets and instrument transformer enclosures measured from the front surface of the socket or enclosure. The final grade or floor in front of the metering equipment must be level and provide a stable standing surface.

1807.2 Minimum Spacing between Metering Equipment and Adjacent Equipment:

Spacing for self-contained meter sockets shall be a minimum of 1-inch on sides and 2-inches at top and bottom of socket enclosures. For transformer rated meter sockets and instrument transformer enclosures, spacing shall be a minimum of 2 inches on sides and bottom and 8 inches at top.

1807.3 Headroom Clearance at Meters:

Headroom above final grade or floor level shall not be less than 6 feet 6 inches or height of metering equipment including the minimum spacing clearances outlined in Article 1807.2 of this Section. Enclosure covers must be readily removable for complete exposure of internal equipment without being blocked by ceilings or overhead objects.

1807.4 Width of Working Space:

The width of the working space in front of the electrical equipment shall be the width of the equipment or 30 inches whichever is greater. In all cases, the workspace shall permit at least a 90-degree opening of equipment doors or hinged panels.

1807.5 Clearance from CPS Energy Gas Regulator:

Gas equipment shall not interfere with minimum clearances outlined herein for metering and service equipment and shall maintain a minimum horizontal clearance of 3 feet from the gas regulator. Measurement shall be taken from the nearest edge of the electrical equipment to the gas regulator. Additional clearances from windows, vents, and other miscellaneous openings and equipment must also be maintained from CPS Energy gas equipment (Refer to Figure 1800.21).

1807.6 Clearance from Receptacles:

A minimum of 4 feet radial distance shall be maintained between receptacle outlets and CPS Energy electric kWh meters.

1808 Grouping of Meters:

In general, where more than one meter is required at a service installation, the meters shall be grouped and supplied by one service lateral or service drop. Meters may only be grouped using one of the following methods:

- (1) Modular Metering Equipment
- (2) Auxiliary Busbar Gutter
- (3) Auxiliary Wire Gutter

1808.1 Grouping Meters with Modular Metering Equipment:

Modular metering equipment will be allowed where the general installation requirements and specifications outlined in this Section have been met and approved by CPS Energy (Refer to Figure 1800.14. The general advantages of using modular metering equipment include:

- (1) An aesthetic appearance.
- (2) Compact, thus requiring less space than field assembled metering equipment.
- (3) Pre-bussed design eliminates the need to wire individual meter sockets to a common bus and to feeder circuit breakers.

Note: CPS Energy will not approve or accept modular metering equipment for commercial single-phase or three-phase applications.

(A) New Construction:

For new construction where Customer elects to use modular metering, all metering on the project must be done using modular type equipment.

Exception 1: *For stand-alone buildings requiring single-phase or three-phase self-contained or transformer rated metering.*

Exception 2: *For individual three-phase loads where modular metering equipment is used for three-wire 120/208-volt loads*

Exception 3: *Where house loads exceed 200 amperes and instrument transformer equipment is required.*

(B) Remodel Construction:

For remodels with existing grouped single position meter sockets, Customer may elect to use modular metering equipment in place of existing metering equipment provided they use it for the entire building that is being remodeled.

Note: *Customer shall not use single position meter sockets for add-ons to modular metering equipment on new or existing installations.*

1808.2 Grouping Meters with an Auxiliary Bus Gutter:

An auxiliary bus gutter is a metal enclosure containing fixed busbars that receives conductors from the source of supply and provides supplementary space for the connection of service-entrance conductors to individual meters.

Only service conductors are allowed within gutter; load wires are not permitted. Gutter shall be furnished, installed, and maintained by Customer (Refer to Figure 1800.15).

(A) Installation:

This method of grouping meters requires that single position meter enclosures, and instrument transformer enclosures, where required, be individually mounted along with the auxiliary bus gutter. The Customer furnished and installed service-entrance conductors to the metering enclosures shall be individually connected to the busbars within the gutter using removable lugs. Customer installs tap conductors (service-entrance), lugs and makes all terminations. Customer shall be responsible for maintaining their service-entrance conductors.

- (1) Auxiliary bus gutters are required for multiple metering on commercial buildings where the supply service conductors or any one set of service-entrance conductors in the gutter exceeds 1-500 KCM or 2-350 KCM copper or aluminum conductors per phase.
- (2) Where an auxiliary bus gutter is required on a service, then all gutters for metering shall be the bus type.

(B) Service-Entrance Conductors to Busbars:

All service-entrance conductors must be connected by Customer directly to busbars in accordance with the applicable diagrams from Figures 1800.5 and 1800.10. All conductors connected within the gutter shall be color coded at their terminations in accordance with Section 400.

(C) Service Lateral (Supply) Conductors to Busbars:

Where CPS Energy owned service lateral is to be connected directly to the busbars in the gutter, CPS Energy will make connections with Customer provided lugs. This junction then will be the POD. Lugs for CPS Energy's conductors must be suitable for copper conductors unless otherwise approved by CPS Energy. At no time will Customer exit the side unless first approved by CPS Energy's Electric Service and Metering Standards Section and when approved, shall be limited to one side exit.

Note: *Where CPS Energy owns the service lateral conductors and terminates to a main disconnect ahead of gutter, such connection shall be made by Customer and this junction will be the POD.*

(D) Step-Bus Design:

All service-entrance conductors for individual meters will exit the gutter immediately above the connections on the busbars. The bus gutters will have service-entrance conductors exiting the top of the gutter; therefore, the top busbars will be closest to the back of the gutter, with the lower busbars progressively closer to the front of the gutter. Conductors shall be terminated on busbars in A-B-C-N phase order from top to bottom.

Exception: *Where bus gutters are installed overhead, all service-entrance conductors will exit the gutter immediately below the connections on the busbars. The step-bus arrangement shall have the bottom busbars closest to the back of the gutter, with the upper busbars progressively closer to the*

front of the gutter. Conductors shall still be terminated on busbars in A-B-C-N phase order from top to bottom.

(E) Construction Specifications:

Auxiliary bus gutters may be designed to suit specific installations, but their general design must be in accordance with the following requirements:

- (1) Gutter must be of corrosion resistant steel and be primed and finish painted, or it may be aluminum. Where applicable it must be weatherproof.
- (2) Gutter shall be constructed of minimum 12-gauge steel or aluminum and shall be adequate to prevent bending or warping.
- (3) Gutters must be designed to allow safe working clearance about electrical service equipment including metering equipment and shall not exceed 18 inches depth unless otherwise approved by CPS Energy's Electric Service and Metering Standards Section.
- (4) Gutter must have non-removable panels (except front covers). It shall not have conduit knockouts.
- (5) Gutter must be equipped with a padlock tongue for each cover, with tongue to extend 3/4 inches minimum outside its cover and have a 3/8-inch aperture for a CPS Energy padlock.
- (6) Covers shall not exceed 6 feet in length and each must be equipped with two lifting handles for safe removal and installation. The gutter must be designed to hold the covers in place after all cover screws are removed. When covers are mounted in place, they must not allow entry of foreign objects around their edges.
- (7) Gutter must be equipped with a grounding lug to accommodate a range of wire sizes up to No. 3/0 AWG.
- (8) Busbars must be rigidly secured on insulators and they shall be in a step-bus design and arranged to prevent wire conductors from lying on or resting against them.
- (9) Busbars must be mounted to have safe clearances between adjacent busbars, grounded parts, and gutter.
- (10) Busbars must have a sufficient number of 9/16-inch holes (non-threaded) to accommodate lugs for connecting the source and service-entrance conductors, plus future meters. Two-hole mounting lugs shall be provided and have the standard NEMA vertical and horizontal spacing of 1 3/4 inches.

Exception: *Bus gutters rated 600 amps or less shall be permitted to have single lug mounting holes on busbars.*

- (11) Busbars must have an ampacity in accordance with the NEC. They may be copper or aluminum. They should be plated to resist corrosion or oxidization at contact surfaces. Silver and tin plating is acceptable for copper and aluminum, respectively.

- (12) Space must be left between each end of the gutter and the busbars to allow for training and connecting incoming source conductors.
- (13) Customer shall furnish single-barrel, two-hole mounting lugs for termination of all conductors onto bus in gutter. Mounting holes in tongue to be 9/16 inches and vertically spaced 1 3/4 inches apart. Cable lug width shall not exceed 1 3/4 inches and height shall not exceed 2 1/4 inches.
- (14) Each lug used shall be plated to industry standards and shall be a type approved for the conductors and for connection to the busbars. When all components are aluminum (bus and lugs), only aluminum bolts and washers should be used.
- (15) Gutter shall be permanently and legibly marked with the voltage and current rating for which they are designed, and with the manufacturer's name or trademark in such a manner as to withstand the conditions. Such marking shall be located inside on the left-side panel near the front of gutter.

(F) Ganging Bus Gutters:

Ganging of bus gutters is acceptable where installed in accordance with the NEC and manufacturer's specifications (Refer to Figure 1800.15).

Note: Approval to gang or extend bus gutters must be coordinated with CPS Energy Field Representative.

1808.3 Grouping Meters with an Auxiliary Wire Gutter:

An auxiliary wire gutter is a metal enclosure used to supplement wiring spaces at meter centers, and similar points of wiring systems. The gutter receives conductors from the source of supply and provides connection points for the service-entrance conductors to individual meters. Gutter and all service-entrance conductors are furnished, installed, and maintained by Customer (Refer to Figures 800.2, 1800.16, and 1800.17.)

(A) Installation:

This method of grouping meters requires that single position meter sockets and instrument transformer enclosures, where required, be individually mounted along with the auxiliary wire gutter. Metering equipment is individually supplied by the service-entrance conductors that are connected to the supply conductors using compression or mechanical connectors suitable and listed for the conductors. Customer makes all terminations.

This type of construction may be used for multifamily type residential buildings, or for multi-occupancy commercial type buildings where any one set of service-entrance conductors in the gutter does not exceed 1-500 KCM or 2-350 KCM conductors per phase.

At no time shall Customer exit the side of the wire gutter unless first approved by CPS Energy's Electric Service and Metering Standards Section and when approved, shall be limited to one side exit.

(B) Overhead Installations:

Auxiliary wire gutters used on the line-side of CPS Energy metering equipment shall be sized as per the NEC, but not be less than 8 inches high with 3/0 AWG conductors or smaller and not less than 10 inches high with conductors larger than 3/0 AWG or any combination of paralleled conductors.

- (1) All service-entrance conductors must be connected by Customer directly to the service conductors within wire gutter in accordance with the applicable diagrams from Figures 1800.3 through 1800.10. All conductors connected within the gutter shall be color coded at their terminations in accordance with Section 400. Non-service conductors are not permitted in the gutter.

(C) Underground Installations (Junction/Pull Box):

Where a CPS Energy owned service lateral must supply directly to a wire gutter, Customer shall furnish and install a weatherproof junction box ahead of gutter in which the service lateral will be terminated. Customer's service-entrance conductors must extend from the wire gutter into the junction box where CPS Energy will terminate them to the service lateral conductors. This junction box then will be the POD (Refer to Figures 800.2 and 1800.17).

Exception: *Junction box is not required where service lateral serves duplex installations and gutters have minimum dimensions of 16 inches (H) x 8 inches (D) x appropriate length required to extend under each meter socket.*

- (1) The junction box shall be constructed of minimum 12-gauge corrosion resistant steel without knockouts, be primed and finish painted, and be equipped with a padlock tongue as described above for auxiliary wire gutters. The minimum dimensions of the junction box shall be based on the size of line-side conduit (not more than 2 conduits permitted) as shown below:
 - (a) For conduit size 2 1/2 or 3 inches: (H) 24 inches, (W) 14 inches, (D) 8 inches;
 - (b) For conduit size 3 1/2 or 4 inches: (H) 36 inches, (W) 18 inches, (D) 10 inches.
- (2) CPS Energy will not connect to more than two conductors per phase and each shall not exceed 350 KCM copper. Single conductors per phase shall not exceed 500 KCM copper. Wire ends in junction box must be 24 inches minimum in length. Where Customer elects to use more or larger conductors per phase, Customer must install an approved bus gutter.
- (3) CPS Energy will not terminate its service lateral conductors in the auxiliary wire gutter. Load wires are not permitted in the gutter or in the junction box with service conductors. The junction box shall only be used to connect the auxiliary wire gutter.
- (4) Where CPS Energy owned service lateral conductors are to be connected directly to the service-entrance conductors in the junction box, CPS Energy will make connections with Customer provided heavy duty pre-

insulated connectors designed for both copper and aluminum conductors. This junction then will be the POD.

(D) Construction Specifications:

Auxiliary wire gutters may be designed to suit specific installations and their general design must be in accordance with the following requirements:

- (1) Gutter must be of corrosion resistant steel and be primed and finish painted, or of aluminum. Where applicable it must be weatherproof.
- (2) Gutter must be constructed of minimum 12-gauge steel or aluminum and shall be adequate to prevent bending or warping.
- (3) Gutter shall be designed to allow safe working clearance about electrical service equipment including metering equipment. Gutters shall be sized in accordance with the NEC but shall not be less than 10 inches in height and not more than 18 inches in depth unless otherwise approved by CPS Energy's Electric Service and Metering Standards Section.

Exception: *CPS Energy will permit 8-inch high gutters where conductors entering are not paralleled and/or are not larger than single 3/0 AWG.*

- (4) Gutter must have non-removable panels (except front covers). It shall not have conduit knockouts.
- (5) Gutter must have hinged, or removable covers provided with locking provisions for CPS Energy.
- (6) Gutter must be equipped with a padlock tongue for each cover, tongue to extend 3/4 inches minimum outside its cover and have a 3/8-inch aperture for a CPS Energy padlock.
- (7) Covers shall not exceed 6 feet in length and be removable. The gutter must be designed to hold the covers in place after all cover screws are removed. When covers are mounted in place they must not allow entry of foreign objects around their edges.
- (8) Gutters must be equipped with a grounding lug to accommodate a range of wire sizes up to No. 3/0 AWG.
- (9) Connectors used in the wire gutter must be a type approved for the conductors. Where aluminum wire is used, grit-filled joint compound must be applied to the connections.

1808.4 Adding Meters for Fire Pumps:

Where a fire pump is required to be individually metered it shall be located adjacent to grouped meters on premise. Metering for fire pumps may consist of a self-contained or instrument transformer rated equipment sized for locked rotor (six times running load) amps.

1808.5 Adding Meters at Existing Service Installations:

Additional meters to be installed at existing service installations must be grouped and have their service-entrance conductors connected in the same manner as required for new installations. On existing commercial buildings

where auxiliary wire gutters are used to group meters, and the wire bus or gutter needs to be enlarged for more load or meters, an auxiliary bus gutter must be used if the supply conductors or any one set of service-entrance conductors in the gutter exceed 1-500 KCM or 2-350 KCM conductors per phase.

1808.6 Grouping Meters at Cell Tower Site Service Installations:

Auxiliary gutters used for cell tower site services shall be installed in accordance with Section 1900. See option 1 or 2 below:

- (1) Service may be designed with a minimum 600 ampere rated main service disconnect on the line-side of an auxiliary wire gutter containing a maximum of 2-350 KCM conductors per phase. Service shall be capable of accepting up to six individual meter loops. Auxiliary Gutter shall be sized as per NEC but in no case be less than 12 inches (H) x 10 inches (D) x 6 feet (L) (Refer to Figure 1900.1)

Note: Customer will be required to furnish and install a step-bus auxiliary gutter where service lateral conductors or any one set of service-entrance conductors are sized larger than 2-350 KCM conductors per phase.

- (2) Service may be designed with minimum 600 ampere rated modular-metering equipment. Modular metering equipment shall be capable of supplying six-meter positions. Where more than six meters are anticipated, a main disconnect shall be incorporated into the design of the modular metering equipment (Refer to Figure 1800.14).

1808.7 Identification of Grouped Metering and Service Equipment:

Where meters are grouped, Customer shall label the service equipment for each tenant with their specific service address to include suite numbers where applicable.

- (1) Where electric meter rooms are approved and used by Customer, address markings also shall be added on instrument transformer and meter enclosures to readily associate with Customer's service equipment.
- (2) Identification must be permanent and be applied by means of stencils and black paint. Use of chalk, ink, crayon, tape, labels, permanent markers, etc. is not acceptable. CPS Energy will not install meters where address identification is missing or does not meet the requirements of this article.
- (3) Where a main disconnecting device is installed in accordance with the NEC it shall be prominently marked to identify its function. The words "MAIN DISCONNECT" shall be prominently displayed (Refer to Figures 1800.14 through 1800.16).
- (4) Address markings must not be obscured when meter sockets, meter enclosures, and disconnecting devices are painted. Address markings and other identification markings must remain legible. Glass meter covers on meters and glass windows in meter enclosures shall not be painted.

- (5) Meters must be wired, and related switches addressed in the sequence shown in Figures 1800.14 through 1800.17. CPS Energy must approve exceptions.

1808.8 Locking and Sealing of Auxiliary Gutters and Enclosures:

CPS Energy will install seals or padlocks on all auxiliary gutters and enclosures that are located on the line-side of its meters. Where Customer must access these devices, they must closely coordinate their activity with CPS Energy's Customer Service Representative.

- (1) Customer shall do no wiring within, or access an auxiliary meter gutter, etc. without first notifying CPS Energy. Customer is not permitted to break or unlock the CPS Energy seals.
- (2) When gutters, etc. are opened or unsealed by CPS Energy for Customer work, Customer shall be responsible for safety of all parties, and for protection of conductors against tampering. When work is not under the direct control and supervision of Customer, then gutters, etc. shall be secured in their closed position. CPS Energy will issue to contractor a one-time lock for securing meter covers, gutters, etc.
- (3) When Customer completes work and has given CPS Energy notice, then CPS Energy will inspect the job and reseal the enclosures. Customer is not permitted to bypass any metering device for the purpose of providing electric service to a tenant.

1809 Use of Metering Equipment:

CPS Energy furnishes metering equipment only once for use on a specific job. Customer is responsible for metering equipment issued to them. Where incorrect metering equipment is issued, the Customer shall contact CPS Energy's Customer Service Representative and a new cabinet work request will be issued. Where the current work request has been closed, the incorrectly issued material must be presented for a material credit before the correct equipment is issued. Customer shall be responsible for installing metering equipment in a neat and workmanlike manner.

Note 1: CPS Energy will not re-issue equipment for the same job without charge.

Note 2: CPS Energy will not issue a material credit for metering equipment that has been damaged or used by Customer as a result of modifications or corrections to service design approved by CPS Energy.

1809.1 Installation of Conduit or Bus Duct in CPS Energy Equipment:

Penetrations in CPS Energy metering enclosures for installing conduits or bus ducts shall be neatly drilled or punched and dressed smoothly. Penetrations shall not be burned in. Conductor sizes No. 4 AWG and larger shall be protected by insulated bushings or other substantial insulating material in accordance with the NEC.

All unused openings in enclosures, sockets, gutters, etc. shall be closed using devices not externally removable. All conduit nipples on CPS Energy meter sockets and enclosures shall be rigid metal conduit (RMC) or intermediate metal conduit (IMC) and provide effective bonding in accordance with the NEC and Section 1700.

1809.2 Mounting of Meter Sockets and Enclosures:

Customer shall mount meter sockets and meter enclosures in an approved manner using good workmanship. They must be mounted plumb, level, and be fastened directly to the building or structure using removable steel fasteners that do not rely on plastic or similar non-metallic expansion mounting anchors. Wooden backers may be used when they are a permanent part of a building or structure, and where they are not exposed to the weather.

CPS Energy will not energize metering equipment installed using unacceptable mounting methods. Customer is responsible for mounting or remounting of their service equipment on building or structure. Removing or remounting of equipment containing CPS Energy metering devices must be coordinated with CPS Energy's Customer Service Representative.

1809.3 Conduit Hubs:

On one meter installations, Customer shall not use a smaller hub nor reduce the hub size furnished by CPS Energy.

Exception: *On grouped metering installations, the hub sizes may be reduced.*

Note: *Where conduit hubs are required on instrument transformer or transformer rated meter enclosures, Customer must furnish and install them. Customer must furnish and install conduit hubs or equivalent devices on auxiliary (meter) gutters. On outdoor installations all such devices must be weatherproof. Conduit hubs shall not be installed with self-tapping screws; machine bolts are required.*

1809.4 Connections to CPS Energy Metering Equipment:

Customer owned equipment such as generators or other voltage sources, load management devices, instruments, relays, etc. shall not be connected to CPS Energy meters or circuits in meter sockets or metering equipment enclosures except where specifically contracted with, and approved by CPS Energy. CPS Energy may determine the location, use, and wiring of such equipment, and where necessary for safety, service reliability, etc. The equipment may be under direct control of CPS Energy, with Customer access only as permitted by CPS Energy.

1809.5 Protection of Open Meter Sockets (All Types):

Where Customer will energize meter sockets, e.g., where sockets are energized from a hot gutter, it shall be Customer's responsibility to close meter socket openings and to secure the sockets' permanent covers in place to protect against shock hazard, tampering, and weather.

- (1) Customer must provide this protection pending the installation of meters by CPS Energy. CPS Energy will, on request by Customer, issue (on loan) socket opening cover plates for ringless meter sockets (Refer to Table 1800.1 for socket opening cover plates).
- (2) CPS Energy will issue to contractors a one-time lock for securing meter sockets, gutters, etc. when contractor's work is complete. Where sockets will not be energized, Customer may protect sockets by covering openings with heavy duty cardboard held firmly in place.

1810 Communication Provisions for Metering:

Where communication with CPS Energy metering equipment is restricted due to location of metering equipment within Customer's building, Customer shall provide meter communication provisions as outlined herein by CPS Energy. Customer shall arrange for this service with CPS Energy prior to construction, for proper coordination and design. Customer shall provide a one-line electrical diagram of the proposed installation during the planning and design stages for review and approval from CPS Energy's Electric Service and Metering Standards Section. The location and type of required communication equipment will be determined by CPS Energy, general guidelines are as follows:

1810.1: Apartment Complexes

For apartment complexes with individually metered apartment units; each grouped meter installation (i.e. meter room, modular meter center) may require provisions for a functional telephone line to be installed adjacent to metering equipment to provide dial in/out service where deemed necessary by CPS Energy.

Exception: Sites provided with ION Power Quality Meters must comply with Article 1810.2.

1810.2: SLP, ELP, and LLP Sites with Square D ION Power Quality Meters:

For these types of sites where metering has been approved by CPS Energy to be located inside a building, the following minimum provisions shall be provided by the Customer:

(A) One Ethernet cable located inside or adjacent to metering equipment, terminated with a male RJ45 plug, and tied to a 100 Mbit/s or better Ethernet network.

Note: TCP ports and additional ports to be determined by CPS Energy and shall be opened at the Customer's firewall in order to allow communications to the metering from CPS Energy software systems.

(B) RJ11 telephone line connection inside or adjacent to metering equipment.

(C) One radio antenna suitable for the cellular band of frequencies (700, 800, 850, 1700, 1900, 2100, 2300, and/or 2500 MHz), matched for 50-ohm impedance, and rated with a 3 dB gain or better.

(1) If the antenna location provides a minimum of 500 feet clear line-of-sight it shall be mounted at least 7 feet above street/ground level.

(2) If the antenna location does not provide a minimum 500-foot clear line-of-sight, then it shall be mounted a minimum of 40 feet above street/ground level

(3) The Customer shall provide the following minimum requirements:

(a) The antenna shall be accessible to CPS Energy personnel

(b) The antenna shall not be surrounded by transmission/reception interfering materials (i.e. metallic walls, cabinets, etc.).

(c) It is preferred the antenna be located on an exterior part of the building, however, if located internally the antenna shall be located as near as possible to the exterior portion of the building for best signal strength.

(4) Antenna Cabling:

(a) One RG8 coaxial cable to the metering communications box, terminated with a male mini UHF connector.

(b) The provided antenna cable shall be one of the three cable types listed below:

1. Belden Low Loss RG8/U Coaxial Cable, Product Number 9914.
2. Andrew Corp Low Lost RG8/U Coaxial Cable, Product Number CNT400.
3. Times Microwave Low Loss RG8/U Coaxial Cable, Product Number LMR400.

Note: *In the event the Customer wishes to use an alternative antenna cable brand, they must first contact CPS Energy for approval.*

(c) The antenna cable shall be installed in minimum 1 1/2-inch conduit from the antenna to each communication box.

(d) The antenna coaxial cable run shall not exceed 200 feet. Installer shall make their best effort to minimize the cable run and prevent excess cable curls and turns.

1810.3 Network Administration:

During installation and configuration of the networking equipment (i.e. routers), the Customer shall provide a network administrator contact person to assist CPS Energy in configuring ethernet communications and testing communications for the watthour meter (i.e. ION). The contact person shall be directly responsible for programming their network routers, firewalls and assigning IP addresses.

1810.4 Acceptance Testing:

Testing of the system shall be performed upon completion of the installation for CPS Energy acceptance. General testing requirements are as follows:

(A) Grounding of the Bus Work:

- (1) The bus work will be de-energized and grounded by Customer prior to acceptance testing by CPS Energy.
- (2) In order for CPS Energy's acceptance test equipment to work properly the bus work shall be grounded on only one end, either the line-side or the load-side.

(B) Work Notifications:

- (1) Customer shall provide at least 3 days (Excluding holidays and weekends) notice for acceptance tests and other work required of CPS Energy metering personnel. Customer may coordinate work requests with CPS Energy's Customer Service Representative.

TABLE 1800.1

STANDARD METERING EQUIPMENT FURNISHED BY CPS ENERGY								
Equipment Code 'No.	Equipment Description	Maximum Wire Size (Cu or Al)	Maximum Amperes	Hub Size Provisions (inches)	Drawing Figure #	Wiring Figure(s)	Max Conduit Size (inches)	Max Number of Conduits
06	Self-Contained, Meter Socket 3-Phase, OH or UG	#3/0	200	2	1800.5	1800.2 1800.6 1800.7 1800.8	2	1
07	Self-Contained Meter Socket 3-Phase, OH or UG	#500 KCM	200	3-1/2	1800.5	1800.2 1800.6 1800.7 1800.8	3-1/2	1
10	Enclosure, CT 26"x30"x9"	2- #250 KCM Per/Phase	N/A	None	1800.11	1800.9 1800.13	3	2
11	Enclosure, CT 50"x32"x14"	3-#500 KCM Per/Phase	N/A	None	1800.11	1800.9 1800.13	4	3
12	Enclosure, CT 60"x48"x14"	4-#750 KCM Per/Phase	N/A	None	1800.11	1800.9 1800.13	4	4
14	Enclosure, 30"x12-1/4"x11-1/2"	N/A	N/A	None	1800.12	1800.10	2	1
15	Enclosure, 32"x32"x11-1/2"	N/A	N/A	None	1800.12	1800.10	2	1
16	Transformer Mounting Bracket, 16", 2-Position	N/A	N/A	N/A		500.6 500.7	N/A	N/A
17	Transformer Mounting Bracket, 23", 3-Position	N/A	N/A	N/A		500.6 500.7	N/A	N/A
20	Transformer-Rated Meter Socket, 6 Terminal, 1-Phase	N/A	N/A	None	1800.12	1800.10	2	1
21	Transformer-Rated Meter Socket, 8 Terminal, 3-Phase	N/A	N/A	None	1800.12	1800.10	2	1
22	Transformer-Rated Meter Socket, 13 Terminal, 3-Phase	N/A	N/A	None	1800.12	1800.10	2	1
23	(OH) Transocket, 3-Phase 4-Wire	2-#500 KCM Per Phase	400	4	1800.18	1800.16 1800.17	4	2
24	(OH) Transocket, 3-Phase 4-Wire	2-#500 KCM Per Phase	800	4	1800.18	1800.16 1800.17	4	2
25	(UG) Transocket, 3-Phase 4-Wire	2- #500 KCM Per Phase	400	N/A	1800.18	1800.16 1800.17	4	2
26	(UG) Transocket, 3-Phase 4-Wire	2-#500 KCM Per Phase	800	N/A	1800.18	1800.16 1800.17	4	2
32	Self-Contained, Meter Socket 3-Phase, OH or UG	2-#250 KCM or 1- 500 KCM Per Phase	320	4	1800.7	1800.6 1800.7 1800.8 1800.10	4	2

TABLE 1800.2

CALCULATED LOADS AND METER SOCKET AMPACITIES			
Service Voltage	Meter Socket Ampacity (See Note 1)	Adjusted Meter Socket Ampacity for Commercial Installations (See Note 2)	Adjusted Meter Socket KVA for Commercial Installations (See Note 3)
120/240 Volts 1-Phase, 3 wire	100	88	21
	200	180	23-43
	320	288	44-69
120/208 Volts 3-Wire (see note 2)	100	88	20
	200	180	21-40
240/120 Volts 3-Phase, 4 Wire	200	180	75
208Y/120 Volts 3-Phase, 4-Wire	200	180	45-65
	320	288	66-105
480Y/277 Volts 3-Phase, 4-Wire	200	180	25-150
	320	288	151-240

Note 1: For commercial installations, the adjusted ampacity column shall be used for service designs.

Note 2: The adjusted calculated load limitations for commercial self-contained meter sockets is due to the potential of increase load that could have an impact on metering equipment.

Note 3: The KVA values matches the adjusted ampacity ratings.

FIGURE 1800.1
CUSTOMER FURNISHED, SELF-CONTAINED, SINGLE-PHASE METER SOCKETS
(CPS ENERGY APPROVED)

CODE 01

- CPS ENERGY MATERIAL NO. 1006484
- AMPACITY: 125-AMPERE
- MINIMUM ALLOWABLE CONDUCTOR SIZE: NO. 8 CU OR AL
- MAXIMUM ALLOWABLE CONDUCTOR SIZES: NO. 2 CU OR AL
- SOCKET WITH 1 1/4-INCH BOLT-ON HUB FOR OVER HEAD SERVICE.
- SOCKET WITH NO HUB (FOR AUXILIARY GUTTER APPLICATIONS)
- MINIMUM DIMENSIONS OF SOCKETS ENCLOSURES: H=10-7/8", W=7-3/4", D=3-1/4"

CODE 02

- CPS ENERGY MATERIAL NO. 1006488,
- AMPACITY: 200-AMPERE
- MINIMUM ALLOWABLE CONDUCTOR SIZE: NO. 2 CU OR AL
- MAXIMUM ALLOWABLE CONDUCTOR SIZES: NO. 3/0 CU OR 4/0 AL
- SOCKET WITH 2-INCH BOLT-ON HUB (FOR OVERHEAD SERVICE APPLICATIONS)
- SOCKET WITH NO HUB (FOR AUXILIARY GUTTER APPLICATIONS)
- MINIMUM DIMENSIONS OF SOCKETS ENCLOSURES: H=15", W=8", D=4"

CODE 27

- CPS ENERGY MATERIAL NO. 1032783
- AMPACITY: 200-AMPERE
- MINIMUM ALLOWABLE CONDUCTOR SIZE: NO. 2 CU OR AL
- MAXIMUM ALLOWABLE CONDUCTOR SIZES: NO. 4/0 CU OR AL
- SOCKET WITH NO HUB (FOR URD APPLICATIONS)
- MINIMUM DIMENSIONS OF SOCKETS ENCLOSURES: H=16", W=13", D= 6"

CODE 31

- CPS ENERGY MATERIAL NO. 1032610
- AMPACITY: 320-AMPERE
- MINIMUM ALLOWABLE CONDUCTOR SIZE: PARALLEL 1/0 OR SINGLE 4/0 CU/AL
- MAXIMUM ALLOWABLE CONDUCTOR SIZES: PARALLEL 250 OR SINGLE 500 CU/AL
- SOCKET PROVIDED WITH DUAL 4-INCH HUB PROVISIONS
- MINIMUM DIMENSIONS OF SOCKET ENCLOSURES: H=38", W=16", D=6"

METER BASES SHALL BE MECHANICALLY STAMPED OR LABELED "CPSB" IN THE UPPER LEFT HAND CORNER. LETTERS TO BE 1/2" MINIMUM IN HEIGHT.

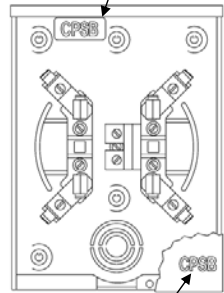

ALL METER SOCKETS SHALL BE MECHANICALLY STAMPED "CPSB" ON THE FRONT PANEL OF ENCLOSURE.

INSTALLATION OF SELF-CONTAINED METER SOCKETS:

1. CUSTOMER LINE AND LOAD CONDUCTORS IN METER SOCKETS SHALL BE SAME SIZE AND AMPACITY AND INSTALLED IN THE SAME MANNER.
2. LINE CONDUCTORS MAY ENTER THE UPPER OR LOWER PORTION OF CODE 31 SOCKETS BUT LOAD CONDUCTORS MAY ONLY EXIT THE LOWER PORTION OF THE SOCKET.
3. PARALLELED CONDUCTORS PERMITTED IN CODE 31 SOCKETS SHALL NOT BE COMBINED IN A COMMON RACEWAY OR CONDUIT.
4. MINIMUM DIMENSIONS SHOWN ABOVE MAY VARY SLIGHTLY DEPENDING ON THE MANUFACTURER.

FIGURE 1800.2
CPS ENERGY FURNISHED, SELF-CONTAINED, THREE-PHASE METER SOCKETS

CODE 06

- CPS ENERGY MATERIAL NO. 1006572
- AMPACITY: 200 AMPERES
- MINIMUM ALLOWABLE CONDUCTOR SIZES: #2 CU OR AL
- MAXIMUM ALLOWABLE CONDUCTOR SIZES: NO. 3/0 CU OR AL
- SOCKET PROVIDED WITH 2-INCH HUB PROVISION:
- DIMENSION OF SOCKET ENCLOSURE: H=18", W=9-7/8", D=4-1/2"
- SOCKET IS ONLY FOR USE ON 4-WIRE, 3-PHASE SERVICES.

CODE 07

- CPS ENERGY MATERIAL NO. 1006570
- AMPACITY: 200 AMPERES
- MINIMUM ALLOWABLE CONDUCTOR SIZE: 4/0 CU OR AL
- MAXIMUM ALLOWABLE CONDUCTOR SIZES: 500 KCM CU OR AL
- SOCKET PROVIDED WITH 3-1/2-INCH HUB PROVISION:
- DIMENSION OF SOCKET ENCLOSURE: H=26", W=12-7/8", D=4-7/8"
- SOCKET IS ONLY FOR USE ON 4-WIRE, 3-PHASE SERVICES, WHERE CONDUCTOR SIZE EXCEEDS NO. 3/0 CU OR AL.

CODE 32

- CPS ENERGY MATERIAL NO. 1042340
- AMPACITY: 320 AMPERES
- MINIMUM ALLOWABLE CONDUCTOR SIZE: PARALLEL 1/0 OR SINGLE 4/0 CU OR AL.
- MAXIMUM ALLOWABLE CONDUCTOR SIZES: PARALLEL 250 OR SINGLE 500 CU OR AL
- SOCKET PROVIDED WITH DUAL 4-INCH HUB PROVISIONS:
- DIMENSION OF SOCKET ENCLOSURE: H=40", W=20", D=6"
- SOCKET IS ONLY FOR USE ON 4-WIRE, 3-PHASE SERVICES, WHERE CALCULATED LOAD EXCEEDS 200 AMPS BUT IS NOT MORE THAN 320 AMPS.

INSTALLATION OF SELF-CONTAINED METER SOCKETS:

1. CUSTOMER INSTALLED LINE AND LOAD CONDUCTORS IN METER SOCKETS SHALL BE SAME SIZE AND AMPACITY AND INSTALLED IN THE SAME MANNER.
2. LINE CONDUCTORS MAY ENTER THE UPPER OR LOWER PORTION OF CODE 32 SOCKETS BUT LOAD CONDUCTORS MAY ONLY EXIT THE LOWER PORTION.
3. PARALLELED CONDUCTORS PERMITTED IN CODE 32 SOCKETS SHALL NOT BE COMBINED IN A COMMON RACEWAY OR CONDUIT.
4. MINIMUM DIMENSIONS SHOWN MAY VARY SLIGHTLY DEPENDING ON THE MANUFACTURER.
5. REFER TO FIGURES 1800.6, 1800.7 AND 1800.8 FOR WIRING INSTRUCTIONS.

FIGURE 1800.3
METER SOCKET WIRING FOR SINGLE-PHASE, 120/240-VOLT, 3-WIRE UNDERGROUND SERVICE

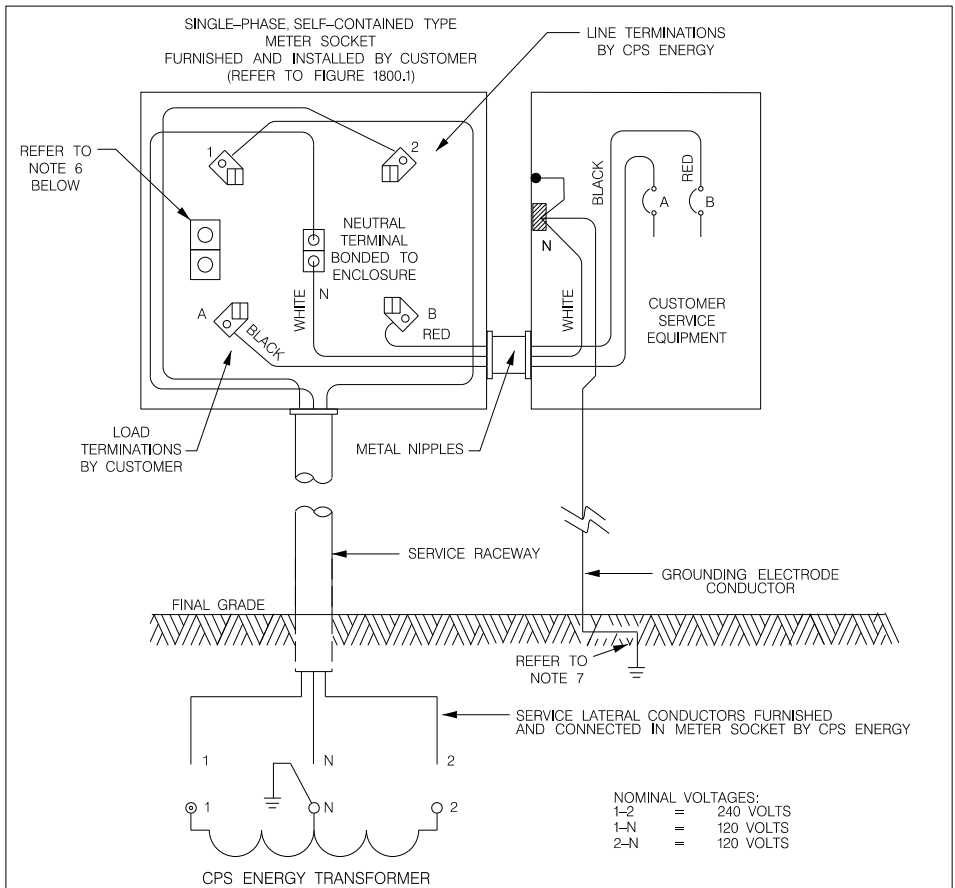

INSTALLATION NOTES:

1. METER SOCKET FURNISHED AND INSTALLED BY CUSTOMER SHALL BE EITHER 125, 200 OR 320 AMPERES AS CONNECTED LOAD REQUIRES. REFER TO FIGURE 1800.1.
2. EXCEPT FOR CPS ENERGY-OWNED SERVICE LATERAL CONDUCTORS, CUSTOMERS MAKES ALL CONNECTIONS IN METER SOCKET.
3. CONDUCTORS SHALL BE IDENTIFIED IN ACCORDANCE WITH SECTION 400.
4. GROUNDING ELECTRODE CONDUCTOR MUST TERMINATE IN SERVICE EQUIPMENT. REFER TO FIGURE 1700.1 FOR OTHER GROUNDING REQUIREMENTS.
5. CUSTOMER'S SERVICE-ENTRANCE CONDUCTORS MAY LEAVE AT TOP OF METER SOCKET. CUSTOMER SHALL FURNISH AND INSTALL CPS ENERGY APPROVED SELF-CONTAINED, SINGLE-PHASE METER SOCKET WITH CONDUIT HUB FOR THIS TYPE OF INSTALLATION (REFER TO FIGURE 1800.1).
6. ON 320-AMPERE SOCKETS THE TERMINATIONS ARE TRANSPOSED TO THE LEFT OF THE ENCLOSURE WITH THE TERMINALS IDENTIFIED FOR PROPER PHASE CONDUCTOR TERMINATIONS.
7. GROUNDING ELECTRODE SYSTEM INSTALLED AS PER NEC TO INCLUDE 5/8- INCH X 8- FOOT GROUND ROD AS REQUIRED BY CPS ENERGY AT ALL CUSTOMER SERVICE LOCATIONS (REFER TO SECTION 1700).

FIGURE 1800.4
METER SOCKET WIRING FOR SINGLE-PHASE, 120/240-VOLT, 3-WIRE OVERHEAD SERVICE

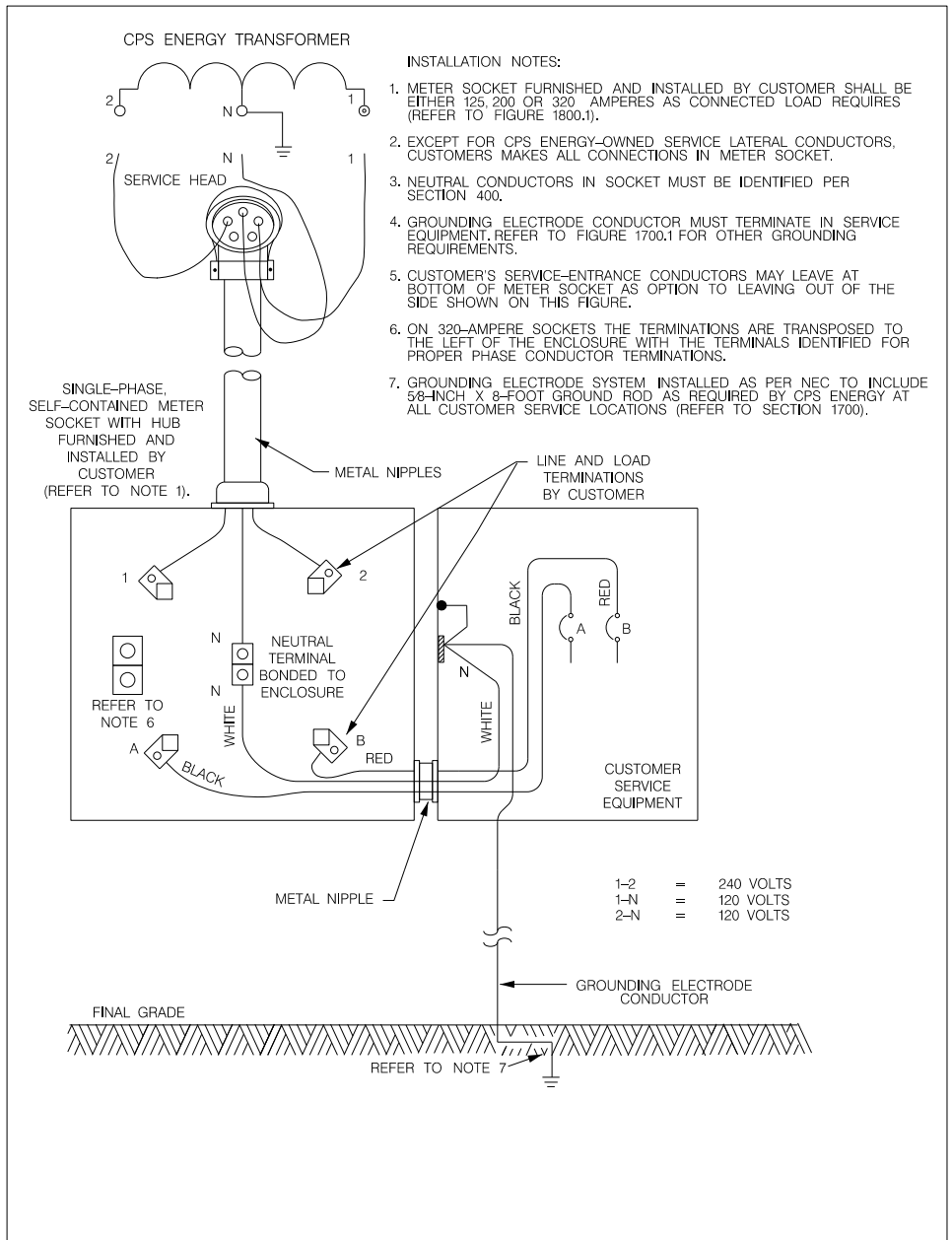
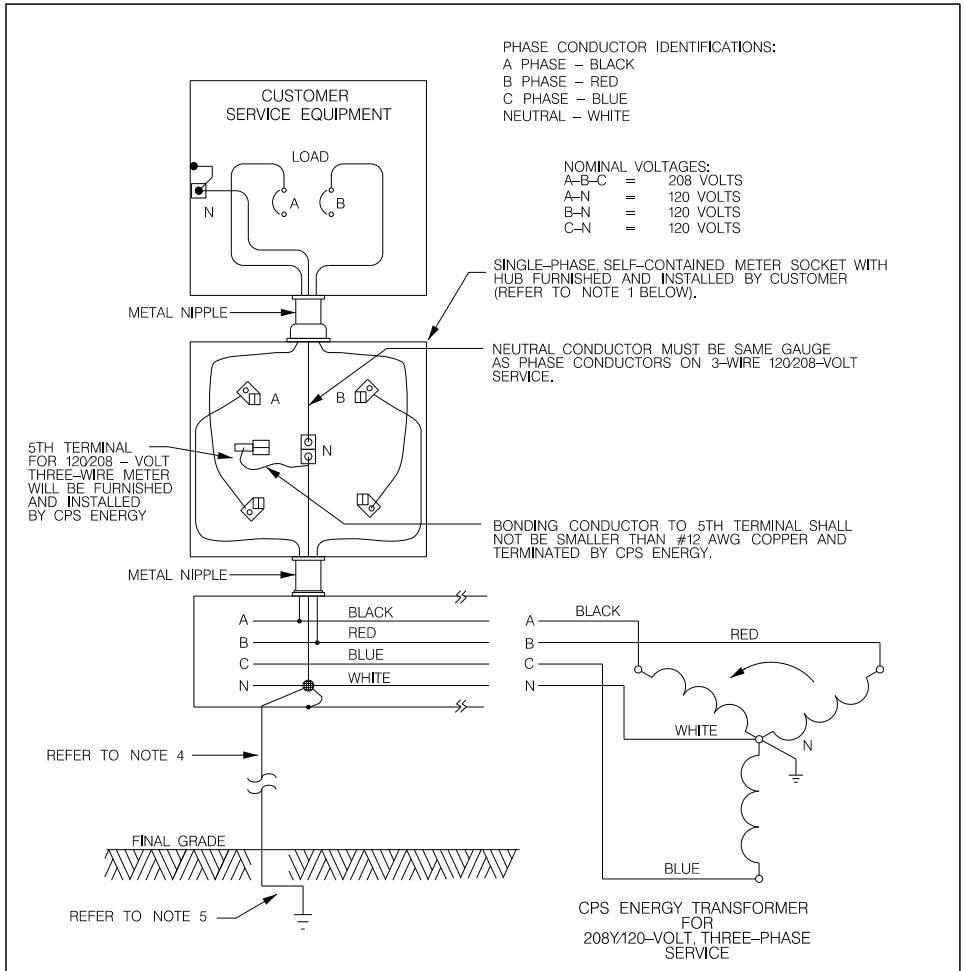

FIGURE 1800.5

METER SOCKET WIRING FOR SINGLE-PHASE, 120/208-VOLT, 3-WIRE METERS IN MULTIPLE METERING DESIGN



INSTALLATION NOTES:

1. METER SOCKET FURNISHED AND INSTALLED BY CUSTOMER SHALL BE EITHER 125 OR 200 AMPERES AS CALCULATED. LOAD REQUIRES, HEAVY-DUTY 320-AMPERE SOCKETS ARE NOT PERMITTED. REFER TO SECTION 1800 AND FIGURE 1800.1.
2. CUSTOMER MAKES ALL CONNECTIONS IN METER SOCKET EXCEPT FOR 5TH TERMINAL.
3. PHASE CONDUCTORS MUST BE ALTERNATED TO OTHER METERS TO BALANCE THE LOAD ON THE 4-WIRE WYE SERVICE. ALL PHASE CONDUCTORS MUST BE COLORED-CODED PER SECTION 400.
4. GROUNDING ELECTRODE CONDUCTOR CONNECTION TO GROUNDED CONDUCTOR IN AUXILIARY GUTTER WHEN THERE IS NO MAIN DISCONNECT AHEAD OF GUTTER AND WHEN GUTTER IS DESIGNED AND INTENDED TO SERVE TWO OR MORE INDIVIDUAL METERS.
5. GROUNDING ELECTRODE SYSTEM INSTALLED AS PER NEC TO INCLUDE 5/8-INCH X 8-FOOT GROUND ROD AS REQUIRED BY CPS ENERGY AT ALL CUSTOMER SERVICE LOCATIONS (REFER TO SECTION 1700).

FIGURE 1800.6
METER SOCKET WIRING FOR 200 AMP THREE-PHASE, 208Y/120-VOLT, 4-WIRE SERVICE

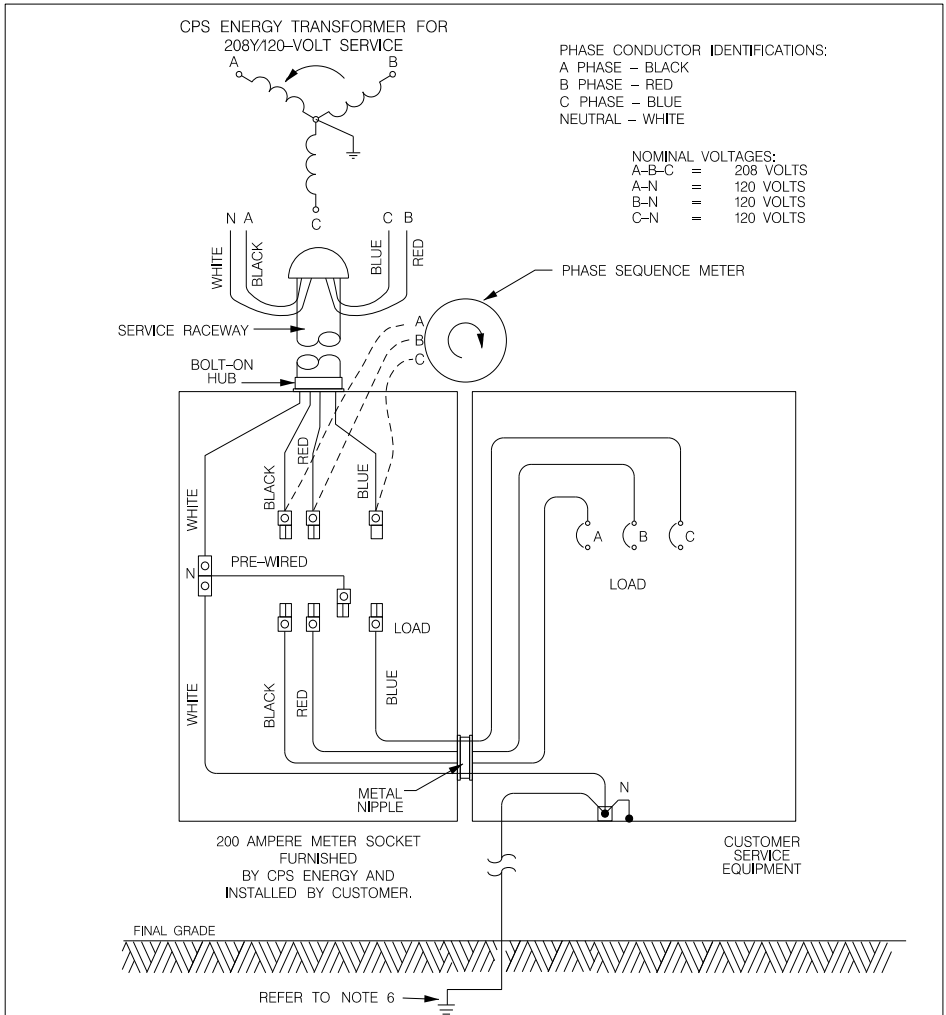

1. METER SOCKET FURNISHED BY CPS ENERGY AND INSTALLED BY CUSTOMER SHALL BE 200 AMPERES, FOR OVERHEAD OR UNDERGROUND AS REQUIRED, REFER TO SECTION 1800, TABLE 1800.1, AND FIGURE 1800.2
2. CUSTOMER MAKES ALL CONNECTIONS IN METER SOCKET, EXCEPTION: CPS ENERGY CONNECTS LINE-SIDE WHEN ITS SERVICE LATERAL ENTERS THE SOCKET.
3. NEUTRAL AND PHASE CONDUCTORS IN SOCKET AND AT SERVICE HEAD MUST BE IDENTIFIED PER SECTION 400.
4. GROUNDING ELECTRODE CONDUCTOR MUST TERMINATE TO GROUNDED CONDUCTOR IN SERVICE DISCONNECT EQUIPMENT.
5. PHASE SEQUENCE METER MUST INDICATE "A-B-C" CLOCKWISE ROTATION WHEN IT'S LEADS ARE CONNECTED A-TO-BLACK, B-TO-RED, AND C-TO-BLUE IN METER SOCKET AS SHOWN HEREIN.
6. GROUNDING ELECTRODE SYSTEM INSTALLED AS PER NEC TO INCLUDE 5/8-INCH X 8-FOOT GROUND ROD AS REQUIRED BY CPS ENERGY AT ALL CUSTOMER SERVICE LOCATIONS (REFER TO SECTION 1700).

FIGURE 1800.7
 METER SOCKET WIRING FOR 320 AMP THREE-PHASE, 208Y/120-VOLT, 4-WIRE SERVICE

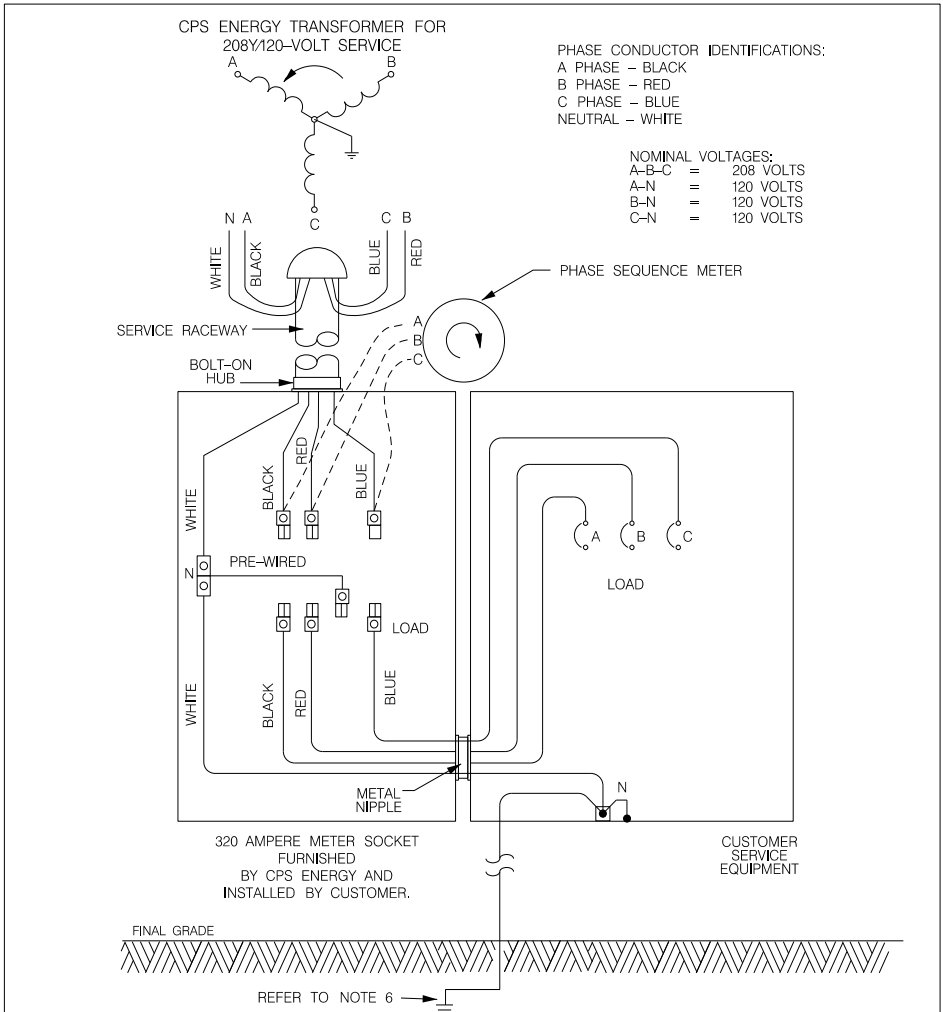

1. METER SOCKET FURNISHED BY CPS ENERGY AND INSTALLED BY CUSTOMER SHALL BE 320 AMPERES, FOR OVERHEAD OR UNDERGROUND AS REQUIRED. REFER TO SECTION 1800, TABLE 1800.1, AND FIGURE 1800.2
2. CUSTOMER MAKES ALL CONNECTIONS IN METER SOCKET, EXCEPTION: CPS ENERGY CONNECTS LINE-SIDE WHEN IT'S SERVICE LATERAL ENTERS THE SOCKET.
3. NEUTRAL AND PHASE CONDUCTORS IN SOCKET AND AT SERVICE HEAD MUST BE IDENTIFIED PER SECTION 400.
4. GROUNDING ELECTRODE CONDUCTOR MUST TERMINATE TO GROUNDING CONDUCTOR IN SERVICE DISCONNECT EQUIPMENT.
5. PHASE SEQUENCE METER MUST INDICATE "A-B-C" COUNTERCLOCKWISE ROTATION WHEN IT'S LEADS ARE CONNECTED A-TO-BLACK, B-TO-RED, AND C-TO-BLUE IN METER SOCKET AS SHOWN HEREIN.
6. GROUNDING ELECTRODE SYSTEM INSTALLED AS PER NEC TO INCLUDE 5/8-INCH X 8-FOOT GROUND ROD AS REQUIRED BY CPS ENERGY AT ALL CUSTOMER SERVICE LOCATIONS (REFER TO SECTION 1700).

FIGURE 1800.8
METER SOCKET WIRING FOR 200 AMPERE THREE-PHASE, 4-WIRE DELTA, 120/240-VOLT SERVICE

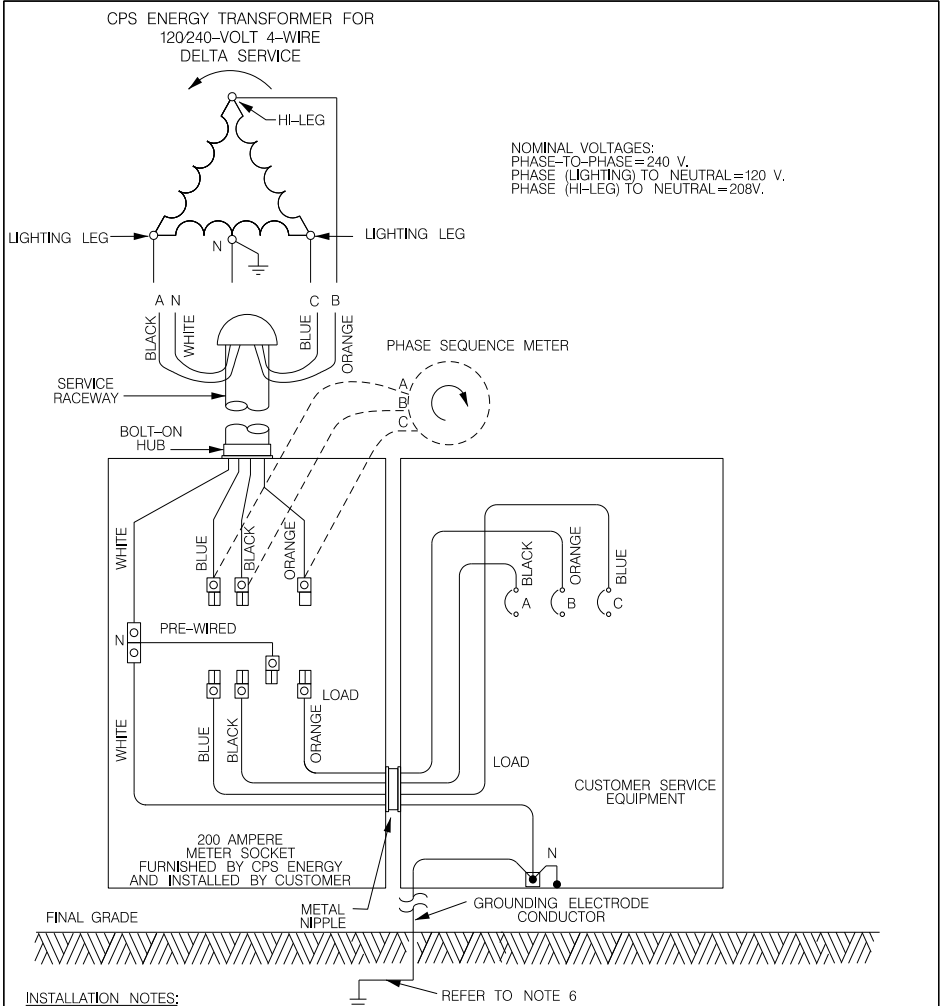

1. METER SOCKET FURNISHED BY CPS ENERGY AND INSTALLED BY CUSTOMER SHALL BE 200 AMPERES. FOR OVERHEAD OR UNDERGROUND AS REQUIRED. REFER TO SECTION 1800 , TABLE 1800.1, AND FIGURE 1800.2
2. CUSTOMER MAKES ALL CONNECTIONS IN METER SOCKET. EXCEPTION: CPS ENERGY CONNECTS LINE-SIDE WHEN IT'S SERVICE LATERAL ENTERS THE SOCKET.
3. NEUTRAL AND PHASE CONDUCTORS IN SOCKET AND AT SERVICE HEAD MUST BE IDENTIFIED PER SECTION 400.
4. GROUNDING ELECTRODE CONDUCTOR MUST TERMINATE TO GROUNDED CONDUCTOR IN SERVICE EQUIPMENT. EXCEPTION: THIS CONNECTION IS ALLOWED IN AN AUXILIARY GUTTER AHEAD OF INDIVIDUAL METERS WHEN THERE IS NOT A MAIN SERVICE DISCONNECT AND GUTTER IS DESIGNED AND INTENDED TO SERVE TWO OR MORE INDIVIDUAL METERS.
5. PHASE SEQUENCE METER MUST INDICATE "A-B-C" OR CLOCKWISE ROTATION WHEN IT'S LEADS ARE CONNECTED A-TO-BLUE, B-TO-BLACK, AND C-TO-ORANGE IN METER SOCKET.
6. GROUNDING ELECTRODE SYSTEM INSTALLED AS PER NEC TO INCLUDE 5/8-INCH X 8-FOOT GROUND ROD AS REQUIRED BY CPS ENERGY AT ALL CUSTOMER SERVICE LOCATIONS (REFER TO SECTION 1700).

FIGURE 1800.9
 METER SOCKET WIRING DIAGRAM, 480Y/277-VOLT, SELF-CONTAINED, FOUR-WIRE, THREE-PHASE,
 200 AMPERES SERVICE (FOUR-WIRE METERS IN MULTIPLE METERING DESIGN)

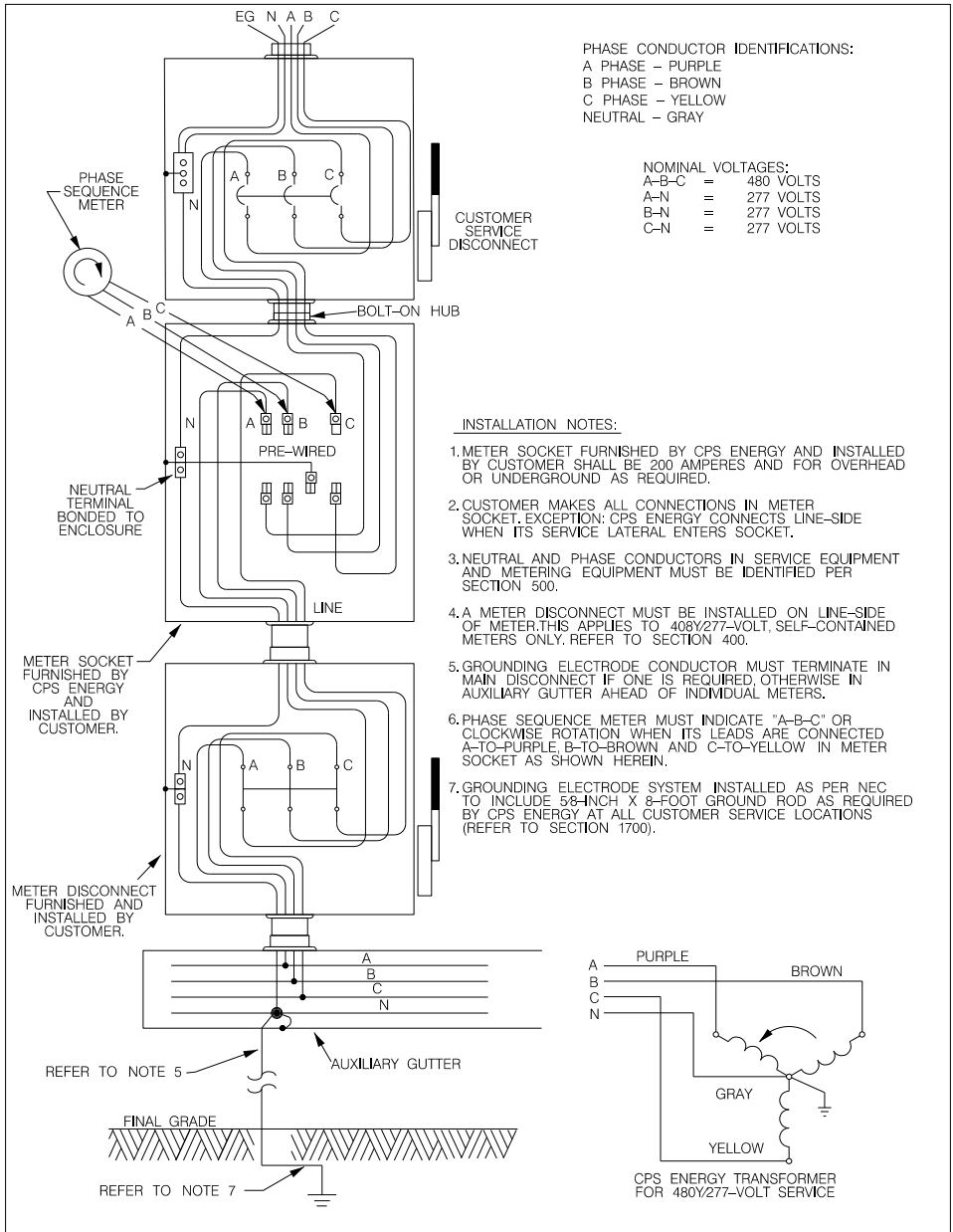

FIGURE 1800.10
 METER SOCKET WIRING DIAGRAM, 480Y/277-VOLT, SELF-CONTAINED, FOUR-WIRE, THREE-PHASE,
 320 AMPERE SERVICE (FOUR-WIRE METERS IN MULTIPLE METERING DESIGN)

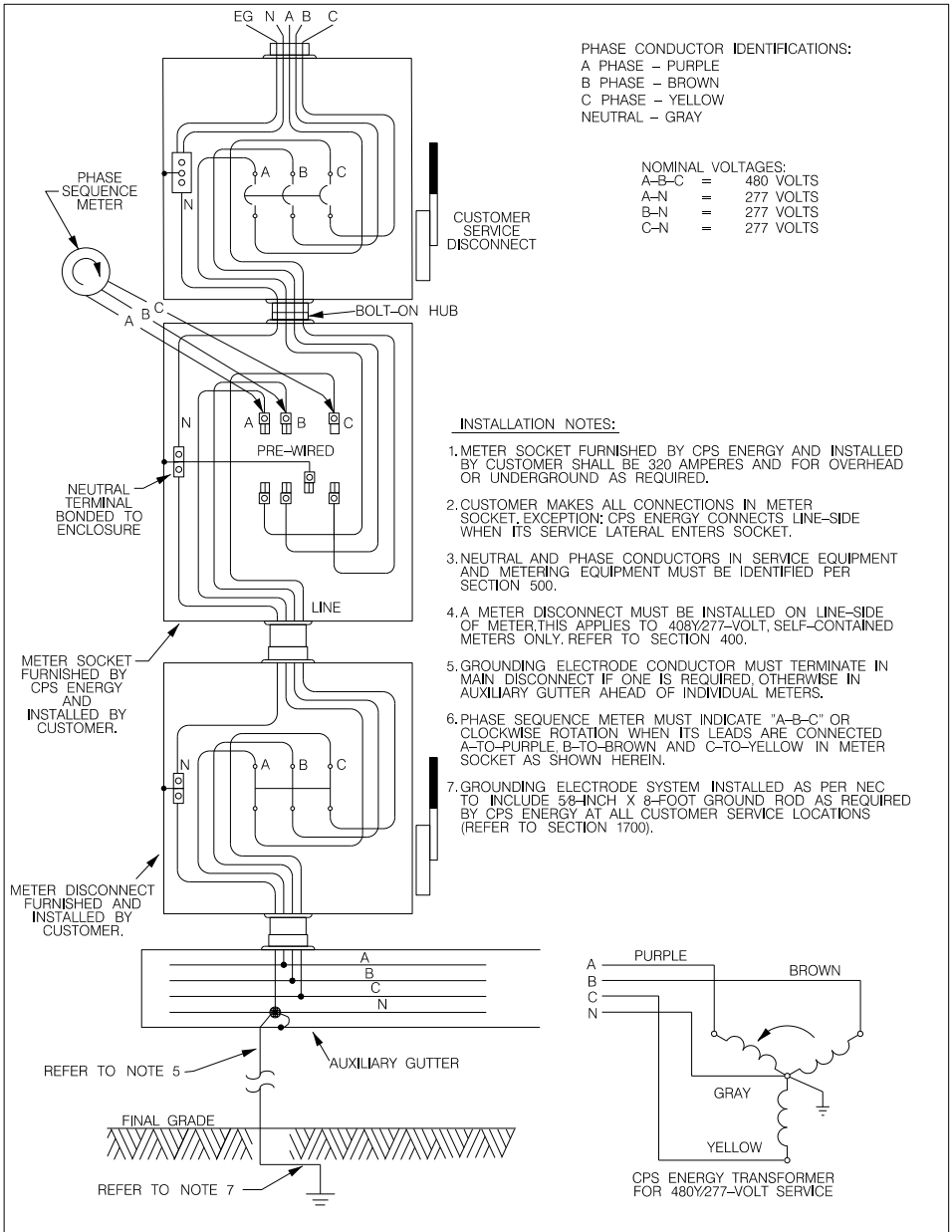
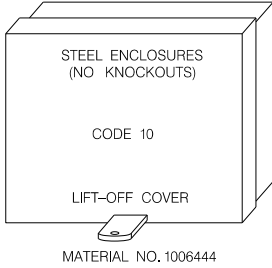
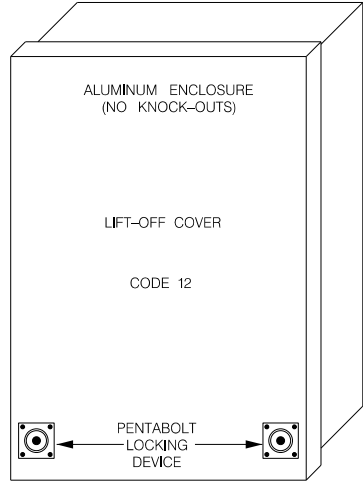

FIGURE 1800.11
WEATHERPROOF INSTRUMENT TRANSFORMER ENCLOSURES



- * MAXIMUM CABLE SIZE 2-250 KCM PER PHASE OR EQUIVALENT KCM IN FEWER CONDUCTORS.
- * MAXIMUM OF (2) 3-INCH CONDUITS PERMITTED.
- * DIMENSIONS:
26 INCHES (H) X 30 INCHES (W) X 9 INCHES (D)
- * NOT PERMITTED FOR USE WITH 480Y/277-VOLT SERVICES



- * MAXIMUM CABLE SIZE 4-750 KCM PER PHASE OR EQUIVALENT KCM IN FEWER CONDUCTORS.
- * MAXIMUM OF (4) 4-INCH CONDUITS PERMITTED.
- * DIMENSIONS:
60 INCHES (H) X 48 INCHES (W) X 14 INCHES (D)
- * MAY BE ADAPTED TO ACCEPT BUSBARS WHEN NEEDED FOR CUSTOM MADE TYPE INSTALLATIONS (REFER TO NOTE 4 BELOW)

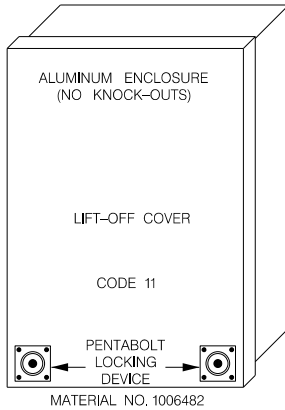

- * MAXIMUM CABLE SIZE 3-500 KCM PER PHASE OR EQUIVALENT KCM IN FEWER CONDUCTORS.
- * MAXIMUM OF (3) 4-INCH CONDUITS PERMITTED.
- * DIMENSIONS:
50 INCHES (H) X 32 INCHES (W) X 14 INCHES (D)

NOTES:

1. ABOVE ARE THE STANDARD ENCLOSURES FOR CPS ENERGY INSTRUMENT TRANSFORMERS. THEY ARE FURNISHED BY CPS ENERGY FOR INSTALLATION BY CUSTOMER.
2. CODE 12 METERING ENCLOSURE MAY BE ADAPTED TO BUSBARS, BUT THEY SHALL NOT HAVE AN AMPACITY GREATER THAN 2000 AMPERES NOR HAVE A WIDTH GREATER THAN 4 INCHES.
3. WHERE STANDARD CPS ENERGY ENCLOSURES ARE NOT SUITABLE, CUSTOMER SHALL FURNISH AND INSTALL AT THEIR EXPENSE AN APPROVED ENCLOSURE. (REFER TO SECTION 1800).
4. CUSTOMER MAY ALSO, WHEN APPROVED BY CPS ENERGY METERING SECTION, INSTALL CT'S AND/OR VT'S IN A SEPERATE COMPARTMENT WITHIN THEIR SWITCHGEAR OR SWITCHBOARD. (REFER TO SECTION 1800).

FIGURE 1800.12
ENCLOSURES/SOCKETS FOR INSTRUMENT TRANSFORMER-RATED METERS

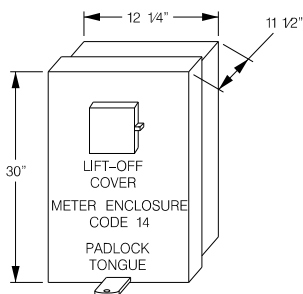

MATERIAL NO. 1006449

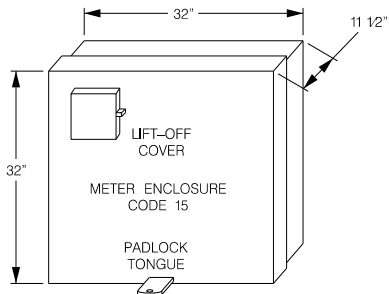

MATERIAL NO. 1006480

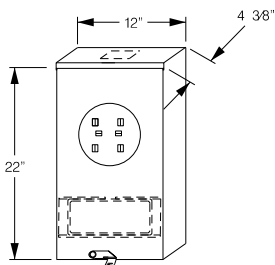

MATERIAL NO. 1033981

TRANSFORMER-RATED
METER SOCKET
CODE 20

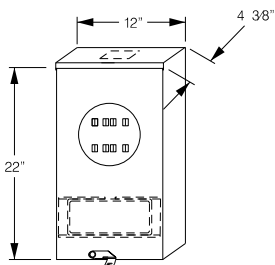

MATERIAL NO. 1033983

TRANSFORMER-RATED
METER SOCKET
CODE 21

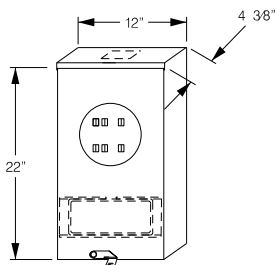

MATERIAL NO. 1033982

TRANSFORMER-RATED
METER SOCKET
CODE 22

CODE 14 OR 15:

THESE ENCLOSURES SHALL BE FURNISHED BY CPS ENERGY FOR INSTALLATION BY A CUSTOMER REQUIRING TOTALIZED METERING OR OTHER SPECIAL METERING CONSIDERATIONS. CPS ENERGY SHALL MAKE FINAL DETERMINATIONS ON METERING DESIGNS TO BE USED.

CODE 20 (SINGLE-PHASE)

THIS SOCKET SHALL BE FURNISHED BY CPS ENERGY FOR INSTALLATION BY A CUSTOMER REQUIRING SINGLE-PHASE, INSTRUMENT TRANSFORMERS (CT'S AND /OR VT'S), CALCULATED LOADS LARGER THAN 320 AMPERES ON SINGLE-PHASE 3-WIRE, 240-VOLT SERVICES, WILL REQUIRE THE USE OF CT'S AND /OR VT'S, ON OUTDOOR WEATHERPROOF CT INSTALLATIONS (AND SOME INDOOR INSTALLATIONS) CUSTOMER MUST FURNISH AND INSTALL A 1 1/4-INCH BOLT-ON HUB ON THE TOP OF THE ENCLOSURE, BUT NOT IN THE CENTER OF ENCLOSURE. HUB MUST BE WEATHERPROOF TYPE ON OUTDOOR INSTALLATIONS, CUSTOMER MUST FURNISH AND INSTALL A 1 1/4 -INCH RMC, OR IMC CONDUIT FROM THE TRANSFORMER MOUNTING BRACKET TO THE METER SOCKET. (REFER TO FIGURES 500.5 AND 500.6), THE METER SOCKET MUST BE INSTALLED WITHIN 20 FEET OF THE CT'S AND /OR VT'S.

CODE 21, CODE 22 (THREE-PHASE)

THESE SOCKETS SHALL BE FURNISHED BY CPS ENERGY FOR INSTALLATION BY CUSTOMER REQUIRING THREE-PHASE INSTRUMENT TRANSFORMERS (CT'S AND /OR VT'S), CALCULATED LOADS LARGER THAN 320 AMPERES PER PHASE WILL REQUIRE THE USE OF CT'S AND /OR VT'S, ON OUTDOOR WEATHERPROOF CT INSTALLATIONS (AND SOME INDOOR INSTALLATIONS) CUSTOMER MUST FURNISH AND INSTALL A 1 1/4-INCH BOLT-ON HUB ON THE TOP OF THE ENCLOSURE, BUT NOT IN THE CENTER OF ENCLOSURE. CUSTOMER MUST FURNISH AND INSTALL 1 1/4-INCH RMC, OR IMC CONDUIT FROM THE TRANSFORMER MOUNTING BRACKET TO THE METER ENCLOSURE. (REFER TO FIGURES 500.5 AND 500.6). THE METER ENCLOSURE MUST BE INSTALLED WITHIN 20 FEET OF THE CT'S AND /OR VT'S.

FIGURE 1800.13
 TYPICAL CURRENT TRANSFORMER INSTALLATION IN
 A STANDARD CT ENCLOSURE ON OVERHEAD TO UNDERGROUND SERVICE

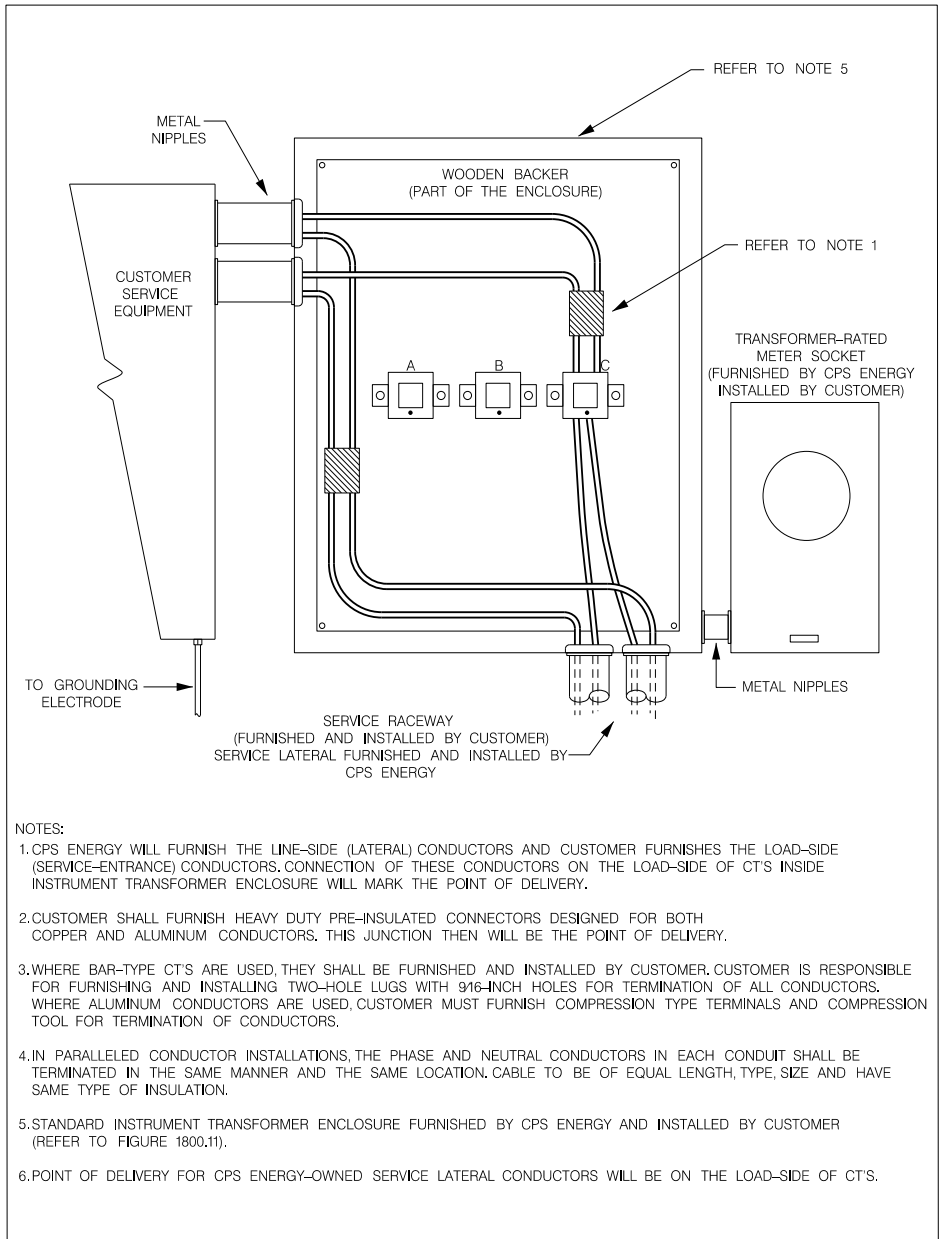

NOTES:

1. CPS ENERGY WILL FURNISH THE LINE-SIDE (LATERAL) CONDUCTORS AND CUSTOMER FURNISHES THE LOAD-SIDE (SERVICE-ENTRANCE) CONDUCTORS. CONNECTION OF THESE CONDUCTORS ON THE LOAD-SIDE OF CT'S INSIDE INSTRUMENT TRANSFORMER ENCLOSURE WILL MARK THE POINT OF DELIVERY.
2. CUSTOMER SHALL FURNISH HEAVY DUTY PRE-INSULATED CONNECTORS DESIGNED FOR BOTH COPPER AND ALUMINUM CONDUCTORS. THIS JUNCTION THEN WILL BE THE POINT OF DELIVERY.
3. WHERE BAR-TYPE CT'S ARE USED, THEY SHALL BE FURNISHED AND INSTALLED BY CUSTOMER. CUSTOMER IS RESPONSIBLE FOR FURNISHING AND INSTALLING TWO-HOLE LUGS WITH 9/16-INCH HOLES FOR TERMINATION OF ALL CONDUCTORS. WHERE ALUMINUM CONDUCTORS ARE USED, CUSTOMER MUST FURNISH COMPRESSION TYPE TERMINALS AND COMPRESSION TOOL FOR TERMINATION OF CONDUCTORS.
4. IN PARALLELED CONDUCTOR INSTALLATIONS, THE PHASE AND NEUTRAL CONDUCTORS IN EACH CONDUIT SHALL BE TERMINATED IN THE SAME MANNER AND THE SAME LOCATION. CABLE TO BE OF EQUAL LENGTH, TYPE, SIZE AND HAVE SAME TYPE OF INSULATION.
5. STANDARD INSTRUMENT TRANSFORMER ENCLOSURE FURNISHED BY CPS ENERGY AND INSTALLED BY CUSTOMER (REFER TO FIGURE 1800.11).
6. POINT OF DELIVERY FOR CPS ENERGY-OWNED SERVICE LATERAL CONDUCTORS WILL BE ON THE LOAD-SIDE OF CT'S.

FIGURE 1800.14
TYPICAL SINGLE-PHASE MODULAR METERING INSTALLATION

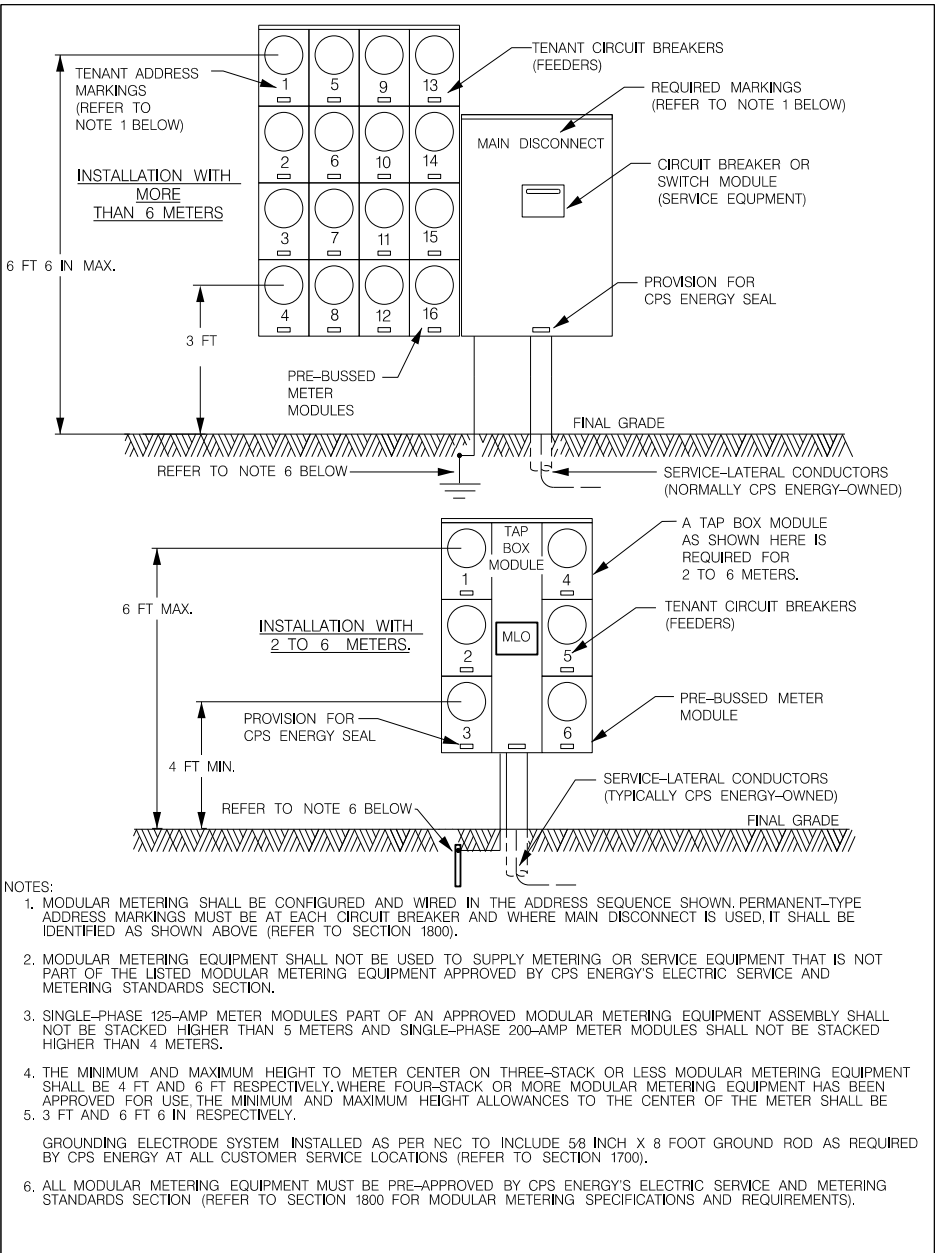

NOTES:

1. MODULAR METERING SHALL BE CONFIGURED AND WIRED IN THE ADDRESS SEQUENCE SHOWN. PERMANENT-TYPE ADDRESS MARKINGS MUST BE AT EACH CIRCUIT BREAKER AND WHERE MAIN DISCONNECT IS USED, IT SHALL BE IDENTIFIED AS SHOWN ABOVE (REFER TO SECTION 1800).
2. MODULAR METERING EQUIPMENT SHALL NOT BE USED TO SUPPLY METERING OR SERVICE EQUIPMENT THAT IS NOT PART OF THE LISTED MODULAR METERING EQUIPMENT APPROVED BY CPS ENERGY'S ELECTRIC SERVICE AND METERING STANDARDS SECTION.
3. SINGLE-PHASE 125-AMP METER MODULES PART OF AN APPROVED MODULAR METERING EQUIPMENT ASSEMBLY SHALL NOT BE STACKED HIGHER THAN 5 METERS AND SINGLE-PHASE 200-AMP METER MODULES SHALL NOT BE STACKED HIGHER THAN 4 METERS.
4. THE MINIMUM AND MAXIMUM HEIGHT TO METER CENTER ON THREE-STACK OR LESS MODULAR METERING EQUIPMENT SHALL BE 4 FT AND 6 FT RESPECTIVELY. WHERE FOUR-STACK OR MORE MODULAR METERING EQUIPMENT HAS BEEN APPROVED FOR USE, THE MINIMUM AND MAXIMUM HEIGHT ALLOWANCES TO THE CENTER OF THE METER SHALL BE 3 FT AND 6 FT 6 IN RESPECTIVELY.
5. GROUNDING ELECTRODE SYSTEM INSTALLED AS PER NEC TO INCLUDE 5/8 INCH X 8 FOOT GROUND ROD AS REQUIRED BY CPS ENERGY AT ALL CUSTOMER SERVICE LOCATIONS (REFER TO SECTION 1700).
6. ALL MODULAR METERING EQUIPMENT MUST BE PRE-APPROVED BY CPS ENERGY'S ELECTRIC SERVICE AND METERING STANDARDS SECTION (REFER TO SECTION 1800 FOR MODULAR METERING SPECIFICATIONS AND REQUIREMENTS).

FIGURE 1800.16
 AUXILIARY WIRE GUTTER WITH 7 OR MORE SELF-CONTAINED, SINGLE-PHASE METER SOCKETS
 STANDARD 120/240V SINGLE-PHASE DESIGN WITH MAIN BREAKER

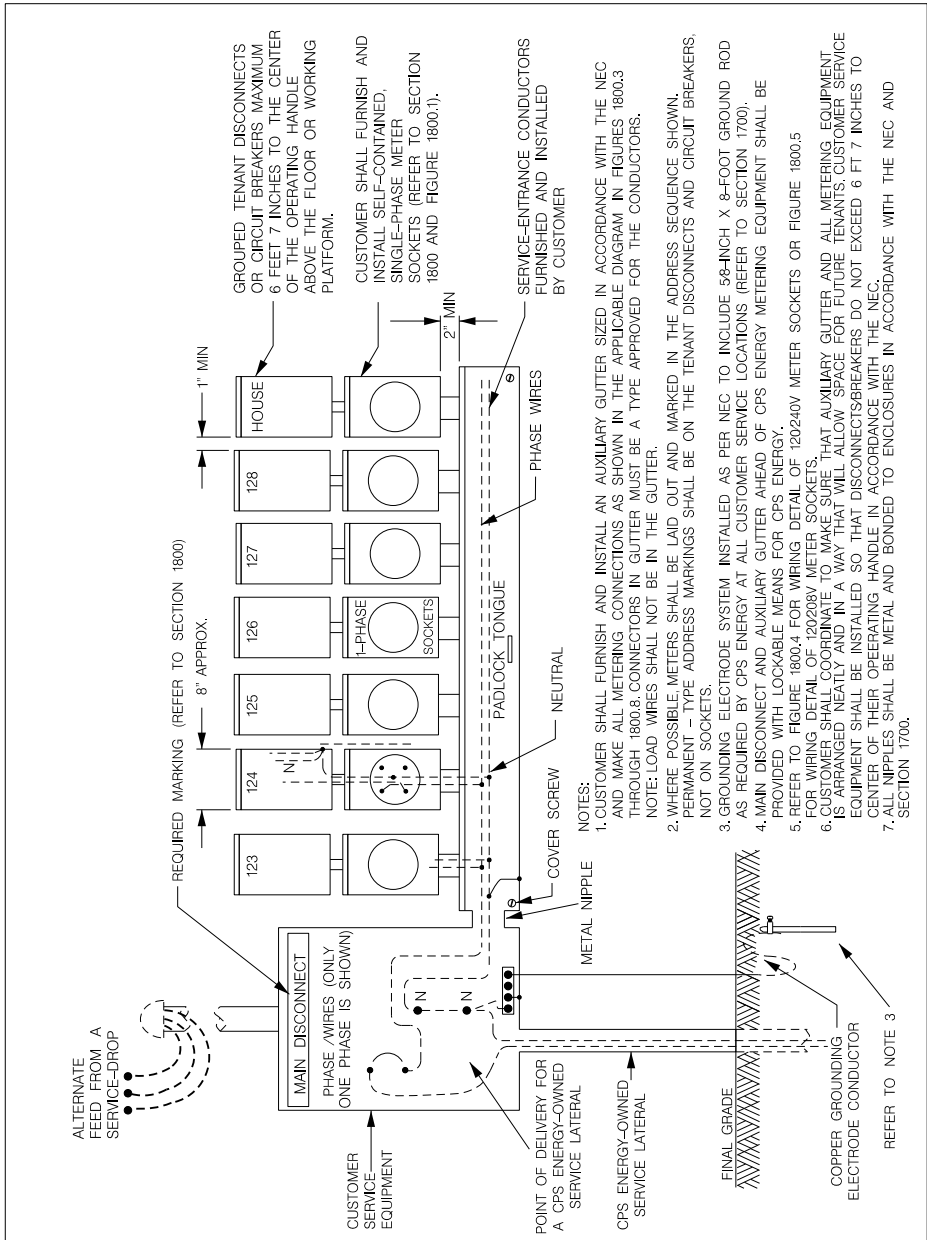

FIGURE 1800.17
 AUXILIARY WIRE GUTTER WITH SIX OR FEWER SELF-CONTAINED, SINGLE-PHASE METER SOCKETS
 STANDARD 120/240V SINGLE-PHASE DESIGN WITHOUT MAIN BREAKER

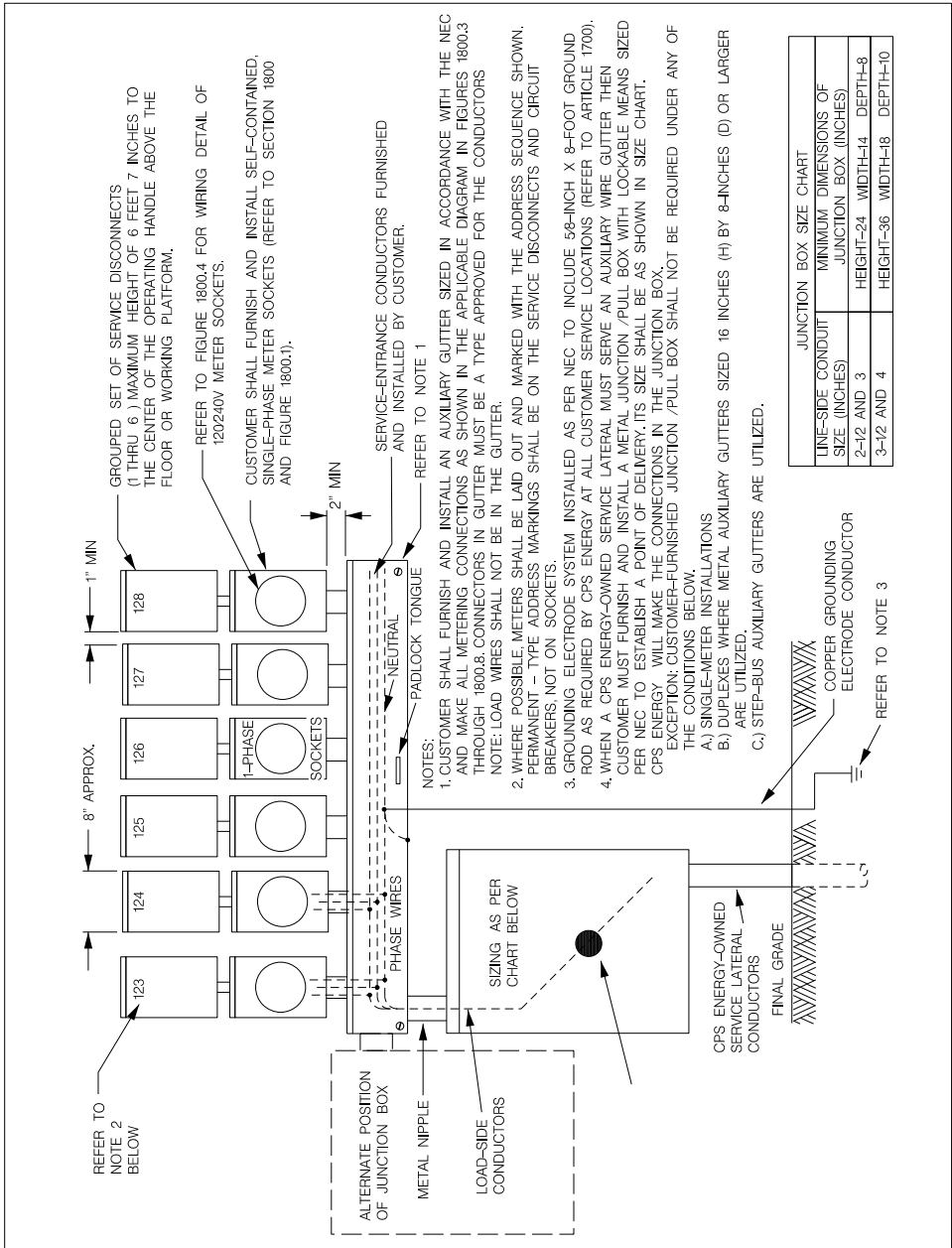
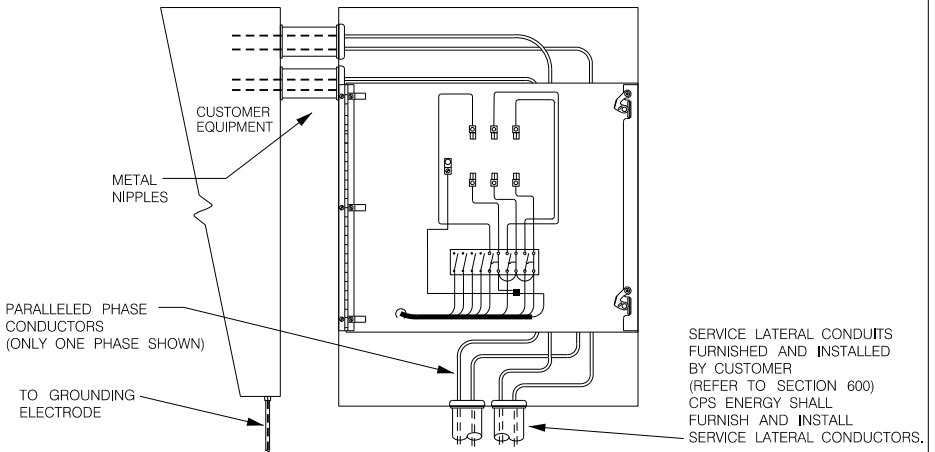
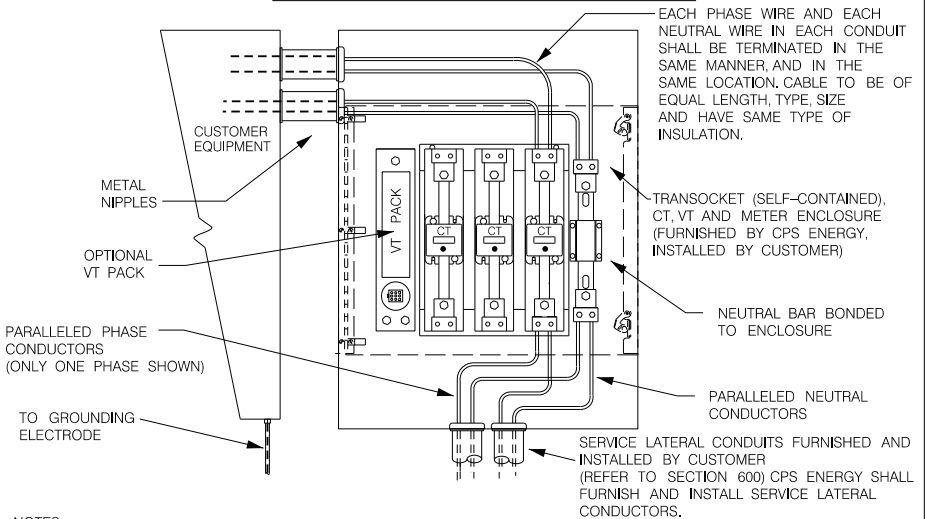

FIGURE 1800.18
 TYPICAL TRANSOCKET INSTALLATION ON OVERHEAD TO UNDERGROUND SERVICE

FRONT VIEW TRANSOCKET
 SHOWING FRONT SWING PANEL CLOSED



FRONT VIEW TRANSOCKET
 SHOWING FRONT SWING PANEL IN OPEN POSITION



NOTES:

1. CUSTOMER FURNISHES AND INSTALLS ALL SERVICE-ENTRANCE CONDUCTORS IN TRANSOCKET. POINT OF DELIVERY IS ESTABLISHED AT THE LOAD-SIDE BUS OF THE CT'S. CPS ENERGY WILL FURNISH AND MAKE CONNECTIONS AT THE CT BUS.
2. TRANSOCKETS ARE PROVIDED WHERE EXISTING OR NEW INSTALLATIONS PROVIDE LIMITED SPACE FOR STANDARD CT ENCLOSURES AND METER SOCKETS. (REFER TO TABLE 1800.1 AND FIGURE 1800.19).
3. TRANSOCKETS SHALL BE MOUNTED SO THAT THE TOP IS A MINIMUM OF 6 FT 6 IN ABOVE FINAL GRADE (REFER TO SECTION 1800).

FIGURE 1800.19
CPS ENERGY FURNISHED TRANSOCKETS

CODE 23

- CPS ENERGY MATERIAL NO. 1031227
- AMPACITY: 400-AMPERE, OVERHEAD (BALANCED)
- ALLOWABLE CONDUCTOR SIZES: 3/0 AWG THRU 500 KCM PARALLEL CU
- MAXIMUM CONDUIT SIZE: 4-INCH
- ENCLOSURE SHALL ACCOMMODATE A MAXIMUM 4-INCH HUB AND BE PROVIDED WITH ECCENTRIC KNOCKOUTS ON EACH SIDE, BOTTOM, AND LOWER BACK.
- MINIMUM DIMENSION OF SOCKET ENCLOSURE: H=36" - 40" OD, W=25" OD, D=12.5" ID
- TRANSOCKET IS ONLY FOR USE WITH 4-WIRE, 3-PHASE SERVICES WHERE SOURCE CONDUCTORS ENTER AT OR NEAR TOP OF ENCLOSURE AND LOAD CONDUCTORS EXIT AT OR NEAR BOTTOM.

CODE 24

- CPS ENERGY MATERIAL NO. 1031228
- AMPACITY: 800-AMPERE, OVERHEAD (BALANCED)
- ALLOWABLE CONDUCTOR SIZES: 350 KCM THRU 500 KCM PARALLEL CU
- MAXIMUM ALLOWABLE CONDUIT SIZE: 4-INCH
- ENCLOSURE SHALL ACCOMMODATE A MAXIMUM 4-INCH HUB AND BE PROVIDED WITH ECCENTRIC KNOCKOUTS ON EACH SIDE, BOTTOM, AND LOWER BACK.
- MINIMUM DIMENSION OF SOCKET ENCLOSURE: H=48" OD, W=25" OD, D=12.5" ID
- TRANSOCKET IS ONLY FOR USE WITH 4-WIRE, 3-PHASE SERVICES WHERE SOURCE CONDUCTORS ENTER AT OR NEAR TOP OF ENCLOSURE AND LOAD CONDUCTORS EXIT AT OR NEAR BOTTOM.

CODE 25

- CPS ENERGY MATERIAL NO. 1042400
- AMPACITY: 400-AMPERE, UNDERGROUND (BALANCED)
- ALLOWABLE CONDUCTOR SIZES: 3/0 AWG THRU 500 KCM PARALLEL CU
- MAXIMUM CONDUIT SIZE: 4-INCH
- ENCLOSURE SHALL ACCOMMODATE A MAXIMUM 4-INCH HUB AND BE PROVIDED WITH ECCENTRIC KNOCKOUTS ON EACH SIDE, BOTTOM, AND LOWER BACK.
- MINIMUM DIMENSION OF SOCKET ENCLOSURE: H=36"- 40" OD, W=25" OD, D=12.5" ID
- TRANSOCKET IS ONLY FOR USE ON 4-WIRE, 3-PHASE SERVICES, WHERE SOURCE CONDUCTORS ENTER AT OR NEAR BOTTOM OF ENCLOSURE AND LOAD CONDUCTORS EXIT AT OR NEAR TOP.

CODE 26

- CPS ENERGY MATERIAL NO. 1042401
- AMPACITY: 800-AMPERE, UNDERGROUND (BALANCED)
- ALLOWABLE CONDUCTOR SIZES: 350 KCM THRU 500 KCM PARALLEL CU
- MAXIMUM ALLOWABLE CONDUIT SIZE: 4-INCH
- ENCLOSURE SHALL ACCOMMODATE A MAXIMUM 4-INCH HUB AND BE PROVIDED WITH ECCENTRIC KNOCKOUTS ON EACH SIDE, BOTTOM, AND LOWER BACK.
- MINIMUM DIMENSION OF SOCKET ENCLOSURE: H=48" OD, W=25" OD, D=12.5" ID
- TRANSOCKET IS ONLY FOR USE ON 4-WIRE, 3-PHASE SERVICES, WHERE SOURCE CONDUCTORS ENTER AT OR NEAR BOTTOM OF ENCLOSURE AND LOAD CONDUCTORS EXIT AT OR NEAR TOP.

FIGURE 1800.20
METERING EQUIPMENT RACK WITH (CT/VT) INSTALLATION

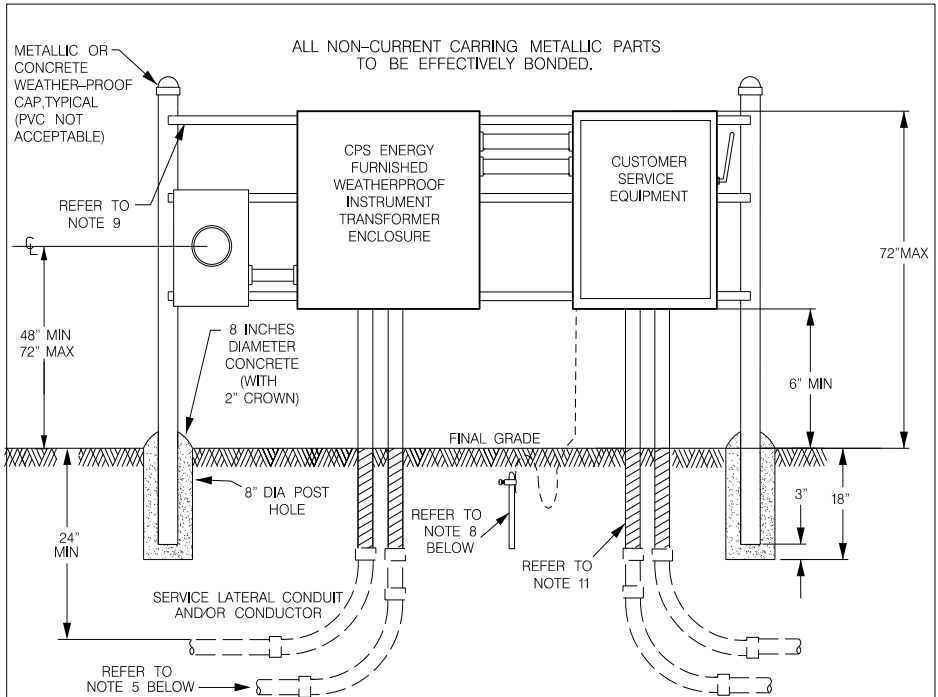

NOTES:

1. SUPPORT RACKS SPANNING 50 1/4 INCHES OR LESS AND DO NOT SUPPORT CT ENCLOSURES, TRANSOCKETS, OR CUSTOMER EQUIPMENT EQUAL OR GREATER IN SIZE SHALL REQUIRE A MINIMUM OF (TWO) 2-INCH RIGID CONDUIT SUPPORTS.
2. SUPPORT RACKS SPANNING GREATER THAN 50 1/4 INCHES OR THAT ARE USED TO SUPPORT CT ENCLOSURES, TRANSOCKETS, OR CUSTOMER EQUIPMENT EQUAL OR GREATER IN SIZE SHALL REQUIRE A MINIMUM OF (TWO) 3-INCH RIGID CONDUIT SUPPORTS.
3. AN ADDITIONAL 3-INCH RIGID CONDUIT SUPPORT SHALL BE UNIFORMLY ADDED TO THE METER RACK DESIGN WHERE THE EQUIPMENT LAYOUT REQUIRES SPANS OF MORE THAN 78 INCHES (6'-6").
4. CUSTOMER SHALL BE RESPONSIBLE FOR ASSURING THAT METERING EQUIPMENT RACK IS PROPERLY BONDED IN ACCORDANCE WITH THE NEC.
5. REFER TO APPLICABLE SECTION OF THESE STANDARDS FOR SERVICE LATERAL CONDUIT AND CONDUCTOR INSTALLATION REQUIREMENTS INCLUDING SIZE AND DEPTH OF CONDUITS (SECTION 600 - OVERHEAD TO UNDERGROUND, SECTION 700-JRD, SECTION 1000 - PADMOUNT SERVICES).
6. BOLLARDS SHOULD BE INSTALLED TO PROTECT EQUIPMENT WHEN INSTALLATION IS SUBJECTED TO VEHICULAR TRAFFIC.
7. INSTALLATION SHALL NOT VIOLATE LINE-OF-SIGHT VISIBILITY CLEARANCES.
8. GROUNDING ELECTRODE SYSTEM INSTALLED AS PER NEC TO INCLUDE 5/8-INCH BY 8-FOOT GROUND ROD AT EACH SERVICE LOCATION (REFER TO SECTION 1700).
9. CROSS BARS SHOULD BE 2" X 3/16" STRAP IRON OR GALVANIZED STEEL CHANNEL, 1 1/2" KINDORF MAY ALSO BE USED FOR CROSS BARS.
10. CUSTOMER SHALL COORDINATE WITH CPS ENERGY'S CUSTOMER SERVICE REPRESENTATIVE TO HAVE METER RACK INSPECTED BY CPS ENERGY DURING CONSTRUCTION.
11. METAL CONDUIT INSTALLED BELOW GRADE SHALL BE SUITABLY COVERED FOR CORROSION PROTECTION.

**FIGURE 1800.21
CLEARANCE REQUIREMENTS
ELECTRIC SERVICE EQUIPMENT AND GAS SERVICE EQUIPMENT**

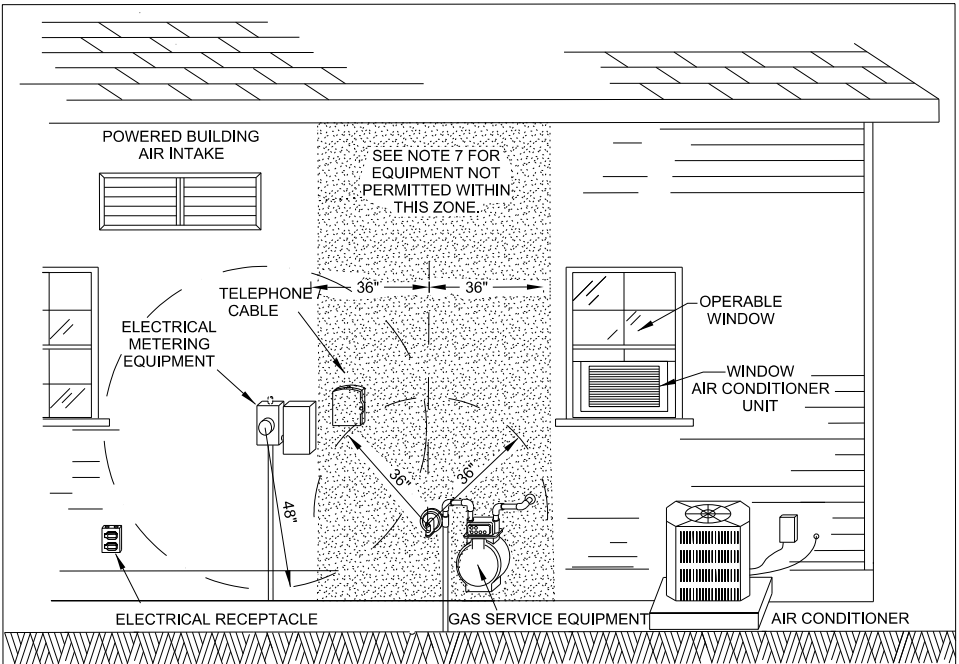

NOTES

1. A MINIMUM OF 48" RADIAL DISTANCE SHALL BE MAINTAINED BETWEEN ELECTRIC METERS AND RECEPTACLES.
2. A MINIMUM OF 36" RADIAL DISTANCE SHALL BE MAINTAINED BETWEEN THE GAS REGULATOR VENT AND ELECTRIC EQUIPMENT INCLUDING RECEPTACLES.
3. GAS METER, GAS REGULATOR, AND ASSOCIATED GAS SERVICE EQUIPMENT SHALL NOT BE LOCATED BENEATH ELECTRIC METER OR ELECTRIC SERVICE EQUIPMENT.
4. THE WORKING CLEARANCE IN FRONT OF THE SERVICE EQUIPMENT INCLUDING THE METERING EQUIPMENT SHALL NOT BE LESS THAN 3 FEET FOR SELF-CONTAINED METER SOCKETS AND NOT LESS THAN 4 FEET FOR TRANSFORMER RATED EQUIPMENT.
5. THE WIDTH OF THE WORKING SPACE IN FRONT OF THE ELECTRICAL EQUIPMENT SHALL BE THE WIDTH OF THE EQUIPMENT OR 30 INCHES WHICHEVER IS GREATER, IN ALL CASES THE SPACE SHALL PERMIT AT LEAST A 90 DEGREE OPENING OF EQUIPMENT DOORS OR HINGED PANELS.
6. THE WORK SPACE SHALL BE CLEAR AND EXTEND FROM THE GRADE, FLOOR, OR PLATFORM TO A HEIGHT OF 6 FEET 6 INCHES OR THE HEIGHT OF THE EQUIPMENT WHICHEVER IS GREATER.
7. COMBUSTION AIR INTAKES, EXHAUST FANS, VENT AND / OR OPERABLE WINDOWS AND DOORS SHALL MAINTAIN A 3 FOOT HORIZONTAL ZONE MEASURED FROM THE REGULATOR AND SUCH ZONE SHALL EXTEND VERTICALLY TO THE EAVE OF THE ROOF.
8. THE GAS METER CANNOT BE LOCATED WITHIN 3 FEET OF ANY DOOR OR UNDER AND / OR WITHIN 3 FEET OF ANY WINDOW THAT OPENS.
9. THE GAS METER CANNOT BE LOCATED WITHIN 10 FEET OF A MECHANICAL AIR INTAKE OR WINDOW INSTALLED AIR CONDITIONER.
10. IF LOCATED TO THE RIGHT OF A WINDOW, THE GAS SERVICE RISER MUST BE A MINIMUM OF 8 INCHES FROM WINDOW FRAME. IF TO THE LEFT OF THE WINDOW, THE CUSTOMER PIPING ENTERING THE STRUCTURE MUST BE A MINIMUM OF 8 INCHES TO THE LEFT OF THE WINDOW FRAME.

SECTION 1900

CELL TOWER SITE AND WIRELESS COMMUNICATION SYSTEM

CELL TOWER SITE AND WIRELESS
COMMUNICATION SYSTEM



1901 General:

This type of service is designed for cell tower sites and wireless communication systems. CPS Energy will provide one service to each cell tower site or wireless communication system location. Customer will be required to design and install a service that meets the provisions outlined in this section. The initial request for service at a cell tower or wireless communication system site by Customer will be reviewed for compliance with the provisions outlined in this section.

1902 New Service Installations for Cell Tower Sites:

Where a new service is to be installed, Customer shall design service in accordance with one of the methods described in (A) and (B) below:

(A) Main Disconnect and Auxiliary Wire Gutter:

Service may be designed with a minimum 600-ampere rated main service disconnect on the line-side of an auxiliary wire gutter containing a maximum of two 350 KCM conductors per phase. Service shall be capable of accepting up to six individual meter loops. Auxiliary Gutter shall be sized as per NEC but in no case be less than 12 inches (H) x 10 inches (D) x 6 feet (L) (Refer to Figure 1900.1)

Note: Customer will be required to furnish and install a step-bus auxiliary gutter where service lateral conductors or any one set of service-entrance conductors are sized larger than two 350 KCM conductors per phase.

(B) Modular Metering Equipment:

Service may be designed with minimum 600-ampere rated modular metering equipment. Modular metering equipment shall be capable of supplying six-meter positions. Where more than six meters are anticipated, a main disconnect shall be incorporated into the design of the modular metering equipment (Refer to Figure 1800.12).

1903 Existing Service Installations:

Where an existing service requires an upgrade or redesign in order to supply an additional tenant's meter loop(s), Customer will be required to modify service in order to comply with one of the methods described in Article 1902 for new services.

Where an existing three-phase service requires an upgrade or redesign to accommodate a single-phase tenant, the single-phase Customer will be required to modify the existing service in order to comply with Article 1902 to serve their load. Where multiple single-phase meter sockets are installed on a three-phase service, the single-phase loads shall be balanced between the three phases.

Note: It is the responsibility of the Customer requesting the upgrade or redesign of an existing service to schedule the necessary power interruption(s) with other cell site Customers while maintaining communication and coordination with CPS Energy.

1904 New Service Installations for Wireless Communication Systems:

Where a new service is to be installed, Customer shall design service in accordance with one of the methods described in (A) thru (D) below:

Note: *Installations listed below must be pre-approved by AHJ.*

(A) Overhead Service on CPS Energy Distribution Pole:

Service and metering equipment shall be designed to be installed on CPS Energy's distribution pole along with necessary communications equipment. CPS Energy distribution pole may be located either on curb side of sidewalk or non-curb side of sidewalk (*Refer to Figures 1900.3 and 1900.4*).

(B) Overhead Service on Customer Meter Pole:

Service and metering equipment shall be designed to be installed on Customer's meter pole along with necessary communications equipment. Customer meter pole shall be located at an approved location on Customer property or a pre-approved location on public right-of-way.

Note: *Pole installation shall be in accordance with Section 1400 and wireless communication equipment shall be installed in accordance with Figures 1900.3 and 1900.4 and Pole Attachment Standards (Refer to "Helpful Numbers" listed on the inside front cover page).*

(C) Underground Service on Customer Meter Pole:

Service and metering equipment shall be designed to be installed on Customer's meter pole along with necessary communications equipment. Customer meter pole shall be located at an approved location on Customer property or a pre-approved location on public right-of-way (*Refer to Figure 1900.5*).

Note 1: *Customer shall be responsible for furnishing and installing meter pole in accordance with Section 1400 but may elect to have CPS Energy install at Customer's expense.*

Note 2: *Where meter pole structures require a concrete base, the conduit riser to the meter socket shall be installed within the concrete base and line up directly under the meter socket (Refer to Figure 1900.2).*

(D) Underground Service on Customer Meter Pedestal:

Service and metering equipment shall be designed to be installed on a pre-approved Customer meter pedestal along with necessary communications equipment. Customer meter pedestal shall be located at an approved location on Customer property or a pre-approved location on public right-of-way (*Refer to Figures 1900.2 and 1900.6*).

Note: *Customer shall be responsible for furnishing and installing meter pedestal but must select one that has been pre-approved by CPS Energy.*

1905 Technical Submittal Information:

Customer shall submit the following information to CPS Energy for approval prior to equipment purchase and installation:

- (1) Meter loop drawings that indicate service disconnect ratings, conduit and wire sizes at all points, meter socket ampere ratings, gutter dimensions, and grounding electrode connections.
- (2) Site plan showing location of all equipment.

SECTION 1900 - CELL TOWER SITES AND WIRELESS COMMUNICAION SYSTEMS

- (3) Modular metering equipment specifications to include the manufacturer's name, catalog number, and equipment type designation.
- (4) Meter pedestal equipment specifications to include the manufacturer's name, catalog number, and equipment type designation. Foundation details in accordance with Section 1500 and/or Figure 1900.2 shall also be included.
- (5) Underground streetlight pole specifications to include the manufacturer's name, catalog number, and equipment type designation.

FIGURE 1900.2
METER PEDESTAL FOR WIRELESS COMMUNICATION SYSTEM

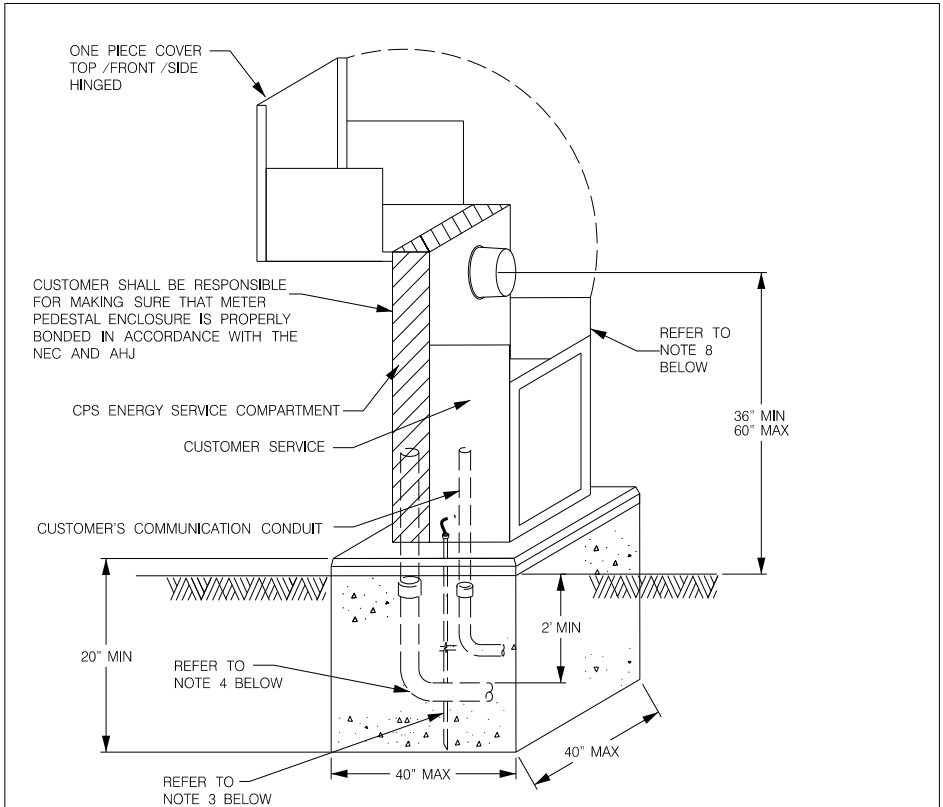

NOTES:

1. CUSTOMER TO INSTALL ALL CONDUITS AND CHANNEL SUPPORT TO CORRECT DEPTH, AND POUR CONCRETE. MOUNTING HOLES MUST LINE UP WITH CHANNEL MOUNTING SLOTS. METER PEDESTAL SHALL BE MOUNTED ON A MAXIMUM 40-INCH BY 40-INCH BY 20-INCH DEPTH CONCRETE BASE. THE METER PEDESTAL MUST BE PRE-APPROVED BY CPS ENERGY AND BE SUITABLE FOR THE CONDITION AND INSTALLED IN ACCORDANCE WITH MANUFACTURER'S INSTRUCTIONS (REFER TO SECTION 1500).
2. GROUNDING ELECTRODE MAY BE INSTALLED ON THE OUTSIDE OF THE METER PEDESTAL. THE GROUNDING ELECTRODE CONDUCTOR MAY BE ROUTED WITHIN THE PEDESTAL AND BONDED TO THE PEDESTAL'S GROUND TERMINAL. GROUNDING CONDUCTOR WITHIN THE METER PEDESTAL SHALL BE AT OR NEAR THE BASE AND ROUTED INTO THE CUSTOMER'S COMPARTMENT AND WILL NOT INTERFERE WITH ACCESS PANELS.
3. MINIMUM 5/8-INCH BY 8- FOOT GROUND ELECTRODE FURNISHED AND INSTALLED BY CUSTOMER IS REQUIRED BY CPS ENERGY AT ALL CUSTOMER SERVICE LOCATIONS.
4. THREE-INCH CONDUIT ELBOW FOR RECEIVING CPS ENERGY SERVICE LATERAL CONDUCTORS, FURNISHED AND INSTALLED BY CUSTOMER, IT MAY BE SCHEDULE 40 OR 80 PVC, OR GALVANIZED RMC OR IMC CORROSION PROTECTED.
5. METER PEDESTAL COVER SHALL BE LOCKABLE AND SEALABLE BY CPS ENERGY.
6. CUSTOMER TO FURNISH AND INSTALL WEATHERPROOF SERVICE EQUIPMENT, MAINTENANCE OF THIS EQUIPMENT WILL BE CUSTOMERS RESPONSIBILITY.
7. CUSTOMER SHALL FURNISH AND INSTALL INTERNAL HUBLESS METER SOCKET. CUSTOMER TO FURNISH AND INSTALL METER PEDESTAL IN ACCORDANCE WITH CPS ENERGY ELECTRIC SERVICE STANDARDS.
8. THREE-FOOT MINIMUM WORKING CLEARANCE SHALL BE MAINTAINED IN FRONT OF METER SOCKET AND REAR OF CPS ENERGY SERVICE COMPARTMENT.

FIGURE 1900.3
 CPS ENERGY DISTRIBUTION POLE
 OVERHEAD SERVICE, SELF-CONTAINED METER(S) FOR WIRELESS COMMUNICATION SYSTEM

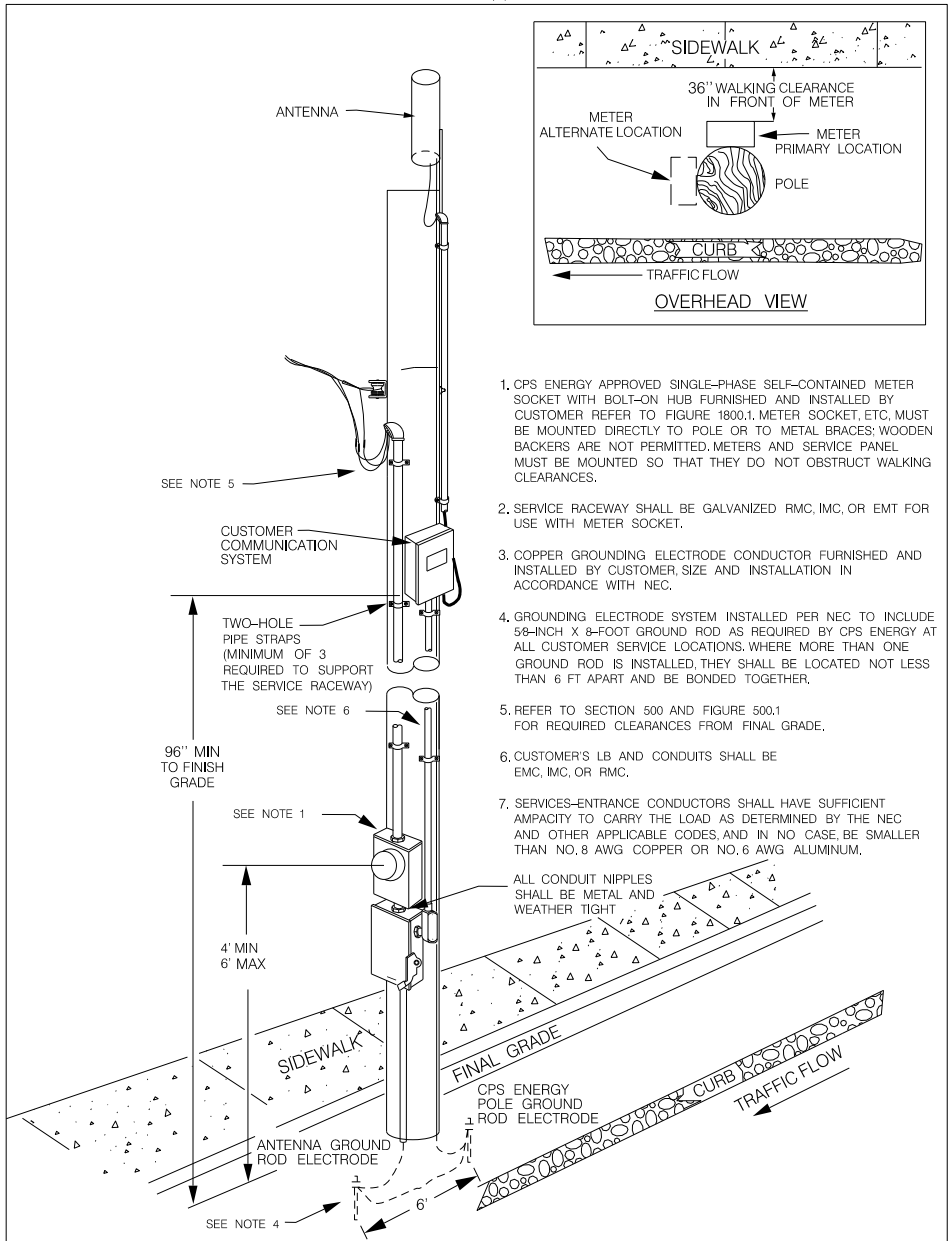
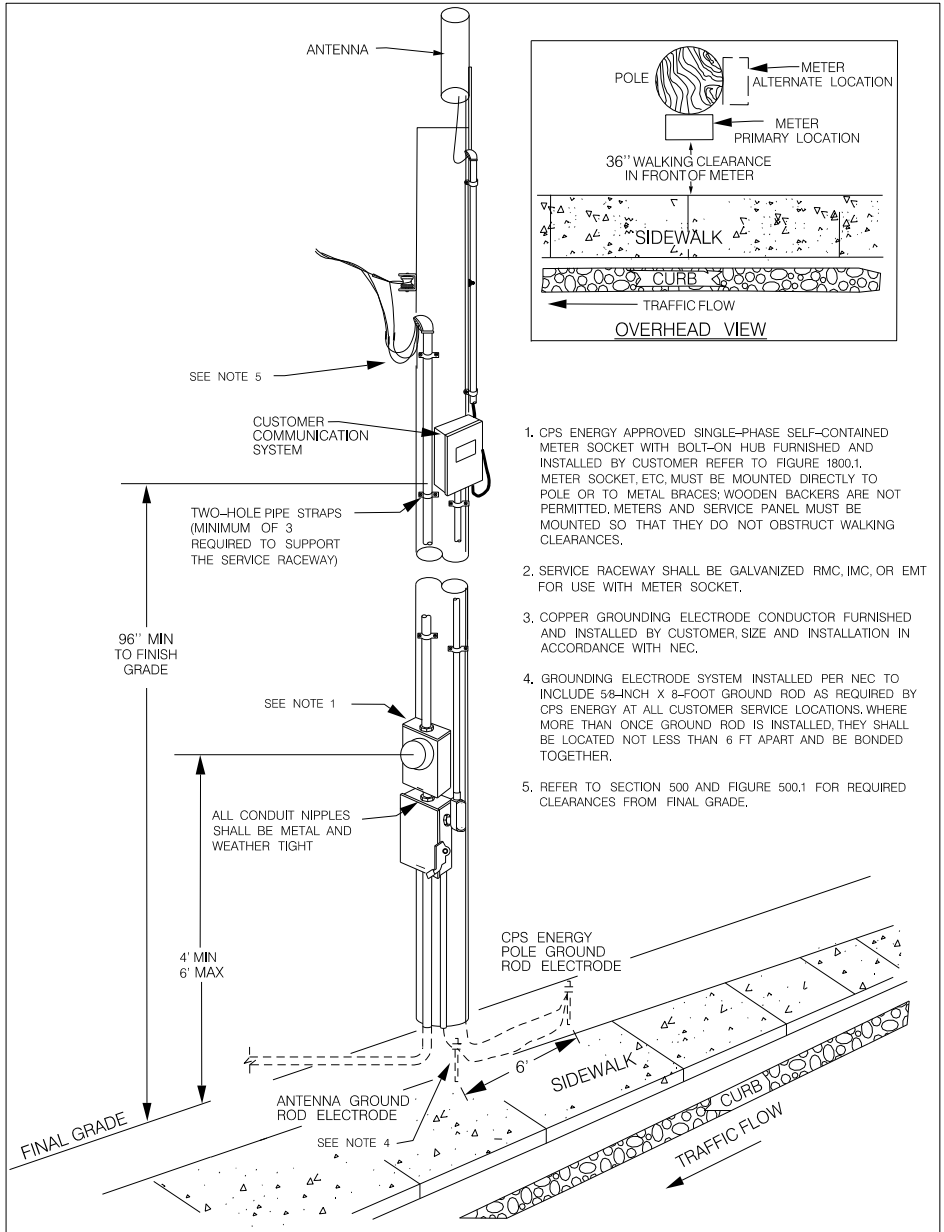

FIGURE 1900.4
 CPS ENERGY DISTRIBUTION POLE
 OVERHEAD SERVICE, SELF-CONTAINED METER(S) FOR WIRELESS COMMUNICATION SYSTEM



1. CPS ENERGY APPROVED SINGLE-PHASE SELF-CONTAINED METER SOCKET WITH BOLT-ON HUB FURNISHED AND INSTALLED BY CUSTOMER REFER TO FIGURE 1800.1, METER SOCKET, ETC, MUST BE MOUNTED DIRECTLY TO POLE OR TO METAL BRACES; WOODEN BACKERS ARE NOT PERMITTED; METERS AND SERVICE PANEL MUST BE MOUNTED SO THAT THEY DO NOT OBSTRUCT WALKING CLEARANCES.
2. SERVICE RACEWAY SHALL BE GALVANIZED RMC, IMC, OR EMT FOR USE WITH METER SOCKET.
3. COPPER GROUNDING ELECTRODE CONDUCTOR FURNISHED AND INSTALLED BY CUSTOMER, SIZE AND INSTALLATION IN ACCORDANCE WITH NEC.
4. GROUNDING ELECTRODE SYSTEM INSTALLED PER NEC TO INCLUDE 5/8-INCH X 8-FOOT GROUND ROD AS REQUIRED BY CPS ENERGY AT ALL CUSTOMER SERVICE LOCATIONS, WHERE MORE THAN ONCE GROUND ROD IS INSTALLED, THEY SHALL BE LOCATED NOT LESS THAN 6 FT APART AND BE BONDED TOGETHER.
5. REFER TO SECTION 500 AND FIGURE 500.1 FOR REQUIRED CLEARANCES FROM FINAL GRADE.

FIGURE 1900.5
 CUSTOMER METER POLE
 UNDERGROUND SERVICE, SELF-CONTAINED METER(S) FOR WIRELESS COMMUNICATION SYSTEM

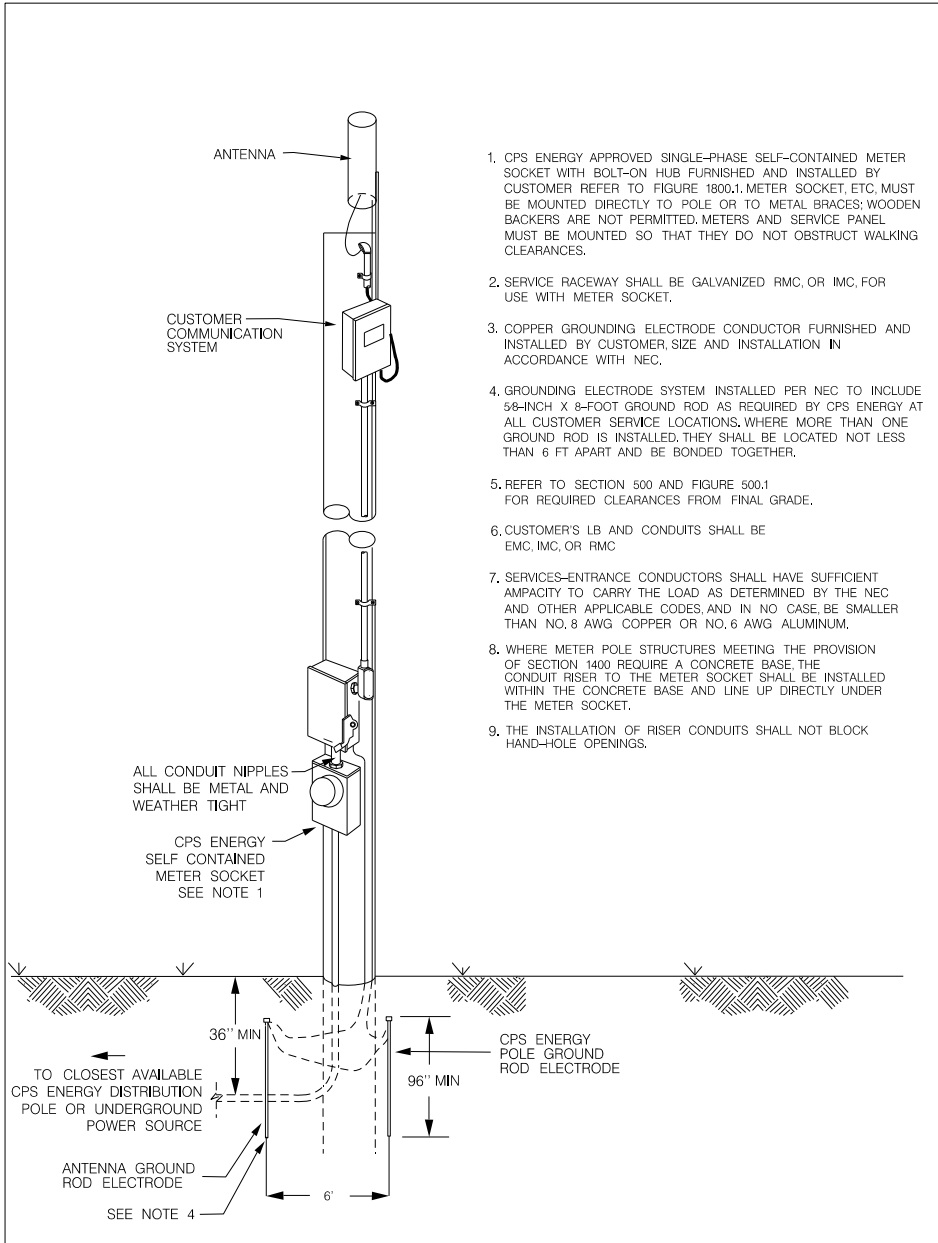
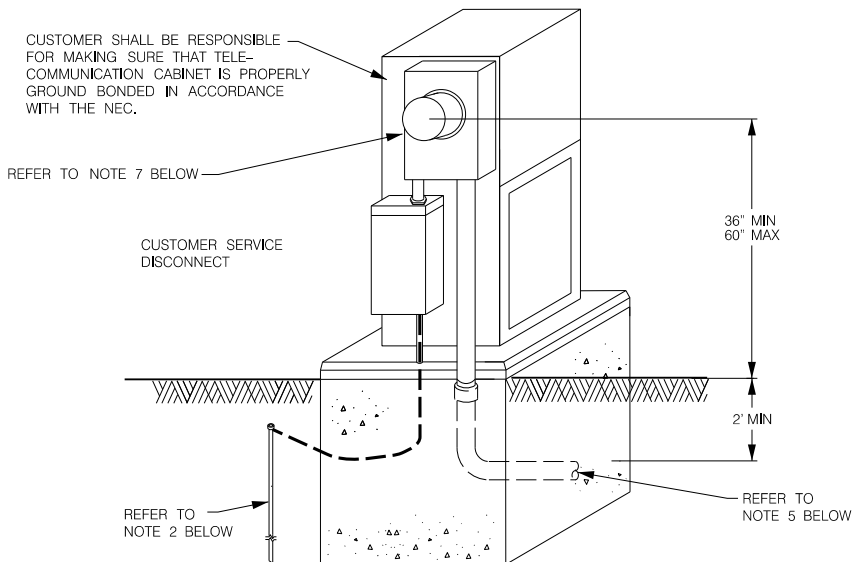

FIGURE 1900.6
METER SOCKET EXTERNALLY MOUNTED ON CUSTOMER'S TELE-COMMUNICATION CABINET



NOTES:

1. WITH PRIOR APPROVAL, METER SOCKET MAY BE EXTERNALLY MOUNTED ON THE TELE-COMMUNICATION CABINET. CUSTOMER TO INSTALL SERVICE CONDUIT AND METER SOCKET MOUNTING SUPPORT AS REQUIRED.
2. CUSTOMER TO INSTALL MINIMUM 58-INCH BY 8- FOOT COPPER GROUNDING ELECTRODE FURNISHED AND INSTALLED BY CUSTOMER AS REQUIRED BY CPS ENERGY AT ALL CUSTOMER SERVICE LOCATIONS. GROUNDING ELECTRODE CONDUCTOR AND CONDUIT INSTALLED EXTERNAL OF THE CUSTOMER'S TELECOMMUNICATION CABINET AND TERMINATE AT THE CABINET'S GROUND BONDING TERMINAL.
3. IN ACCORDANCE WITH THE NEC, AHJ, AND CPS ENERGY, THE GROUNDING ELECTRODE CONDUCTOR SHALL BE BONDED TO THE GROUND CONDUCTOR WITHIN THE TELE-COMMUNICATION CABINET. PENETRATION INTO CABINET SHALL BE AT OR NEAR THE BASE AND DONE SO AS TO NOT INTERFERE WITH ACCESS PANELS.
4. GROUNDING ELECTRODE SYSTEM MAY ALSO INCLUDE OTHER ELECTRODES AS REQUIRED BY THE NEC AND OTHER APPLICABLE CODES (REFER TO SECTION 1700).
5. THREE-INCH CONDUIT ELBOW FOR RECEIVING CPS ENERGY SERVICE LATERAL CONDUCTORS, FURNISHED, AND INSTALLED BY CUSTOMER. IT MAY BE SCHEDULE 40 OR 80 PVC, OR GALVANIZED RMC OR IMC CORROSION PROTECTED.
6. CUSTOMER TO FURNISH AND INSTALL WEATHERPROOF SERVICE EQUIPMENT. MAINTENANCE OF THIS EQUIPMENT WILL BE CUSTOMERS RESPONSIBILITY.
7. CUSTOMER SHALL FURNISH AND INSTALL HUBLESS METER SOCKET. CUSTOMER TO FURNISH AND INSTALL IN ACCORDANCE WITH CPS ENERGY ELECTRIC SERVICE STANDARDS. THREE-FOOT MINIMUM WORKING CLEARANCE SHALL BE MAINTAINED IN FRONT OF METER SOCKET.
8. MOUNTING OF THE METER SOCKET ON THE TELECOMMUNICATION CABINET MUST BE PRE-APPROVED BY CPS ENERGY AND BE SUITABLE FOR THE CONDITION AND INSTALLED IN ACCORDANCE WITH MANUFACTURER'S INSTRUCTIONS.

SECTION 2000

DISTRIBUTED GENERATION



2001 General:

Customer may operate 60 Hertz (Hz), single-phase or three-phase generating equipment in parallel with CPS Energy's electric distribution system pursuant to completing a Distributed Generation (DG) Application and submitting a design and drawings that are approved by CPS Energy. The design will need to be in accordance with this section and supporting CPS Energy documents referenced herein including the Distribution Generation (DG) Manual.

Customer shall coordinate with CPS Energy's Electric Service and Metering Standards Section for information regarding terms, conditions, and requirements for interconnection with CPS Energy facilities. Information may also be found online at www.cpsenergy.com.

Note: *No DG Facility shall be operated in parallel with CPS Energy's electric distribution system without first meeting all application, plan review, and field commissioning requirements and obtaining express written consent from CPS Energy's Distributed Planning Section.*

2002 Scope and Applicability:

While there are numerous types of DG technologies available, such as Solar Photovoltaic (PV), wind, combined heat and power, fuel cells, micro-turbines, reciprocating engines, Stirling engines, energy storage, landfill gas, and diesel, the information contained herein will concentrate on systems of 500 kW and below and give special attention to net-metered PV systems which are typically interconnected on the load-side of the Customer revenue meter. Customers wishing information on larger systems or grid-tied systems may contact CPS Energy's Electric Service and Metering Standards Section and/or reference the DG Manual which can be found online at www.cpsenergy.com.

2003 Downtown Network System Interconnection of DG:

CPS Energy's Downtown Network System presents unique challenges for interconnecting DG Facilities. Customers requesting to install DG in the Downtown area shall coordinate such requests with CPS Energy's Electric Service and Metering Standards Section and the Network Engineering Section (Refer to DG Manual).

2004 CPS Energy Facilities and System Modifications:

The installation of Customer DG Facilities may require construction of new facilities on CPS Energy's side of the Point of Delivery (POD) or modifications to existing supply facilities. The determination of the need for system modifications is made by CPS Energy during the application and design review stage.

There may be costs to the Customer as a result of CPS Energy having to make necessary arrangements for interconnection of the DG facility. *CPS Energy will own and operate all Interconnection Facilities that are installed on the CPS Energy side of the POD (Refer to Definition of "Interconnection Facilities").*

Note 1: *Where deemed necessary, CPS Energy retains the right to install at Customer's expense, communications, telemetry, and related monitoring equipment to monitor and evaluate performance of the DG Facility.*

Note 2: *While CPS Energy accepts no liability related to the installation and operation of DG Facilities, it is required that the design and installation*

utilize qualified and experienced contractors, consultants, and where required, licensed engineers and that work be performed in accordance with minimum requirements of the NEC and other applicable codes and be in accordance with industry best practices.

2005 Customer DG Facilities:

Customer will own, operate, maintain, and be responsible for DG Facilities and for the costs of any other protective facilities which CPS Energy deems necessary or prudent in order to protect CPS Energy's distribution system from disruption or damage caused by the DG Facility (Refer to Definition of "Distributed Generation Facilities").

Note: *CPS Energy will own and operate all Interconnection Facilities that are installed on the CPS Energy side of the POD (Refer to Definition of "Interconnection Facilities").*

2005.1 CPS Energy Disconnection from DG Facilities:

CPS Energy shall have the right to disconnect from DG Facilities where continuance of service to Customer will, in CPS Energy's reasonable determination, endanger persons or property. CPS Energy also reserves the right to disconnect for other cases as described in CPS Energy's DG Manual.

2005.2 Design Considerations of DG Facilities:

Customer's equipment shall be designed in accordance with but not limited to UL Standards, Institute of Electrical and Electronics Engineers (IEEE) Standards, the National Electrical Code (NEC), the National Electrical Safety Code (NESC), the Energy Reliability Council Of Texas (ERCOT) Operating Guides, CPS Energy Electric Service Standards, and any other applicable local, state, or federal codes or standards (Refer to Figures 2000.1 thru 2000.5).

(A) Protection and Coordination:

Customer's DG Facilities shall be designed with listed equipment and protective hardware and software designed to prevent connection to de-energized CPS Energy circuits.

Customer shall also be responsible for protecting DG equipment in such a manner that CPS Energy system outages, short-circuits or other disturbances including zero sequence currents and ferroresonant over-voltages do not damage the Customer's DG equipment.

Note: *Surge protection required as outlined in Figures 2000.2 and 2000.4.*

(B) Parallel Operation:

Customer's DG Facilities shall be equipped with the necessary protective hardware and software designed to prevent connection or parallel operation of DG equipment with CPS Energy's distribution system unless the CPS Energy voltage and frequency is of normal magnitude.

(C) Metering/Measuring Energy at DG Facilities:

DG Facilities shall have provisions and necessary equipment to measure both the energy produced by the DG Facility (PV Meter) and any energy provided by CPS Energy for Customer's use (PV Billing Meter) at DG sites.

CPS Energy shall review all DG designs and make final determination on metering and communications equipment required including location.

Note 1: *The PV meter shall be located immediately adjacent to the Billing meter unless otherwise approved by CPS Energy.*

Note 2: *In no case will CPS Energy permit the PV meter to be located on floor(s) other than the level that the revenue meter is located.*

(A) Prevention of Interference:

Operating requirements for DG Facilities are described in the DG Manual.

(B) Wiring of Self-Contained PV System Meter Sockets:

Customer shall furnish and terminate all conductors within self-contained meter sockets used for PV System installations.

- (1) Line and load conductors in the socket must have the same ampacity rating and not be smaller than No.8 AWG Copper for 100-amp single-phase meter sockets, not smaller than No. 6 AWG Copper for 200-amp single-phase meter sockets, and not smaller than No. 2 AWG for 200-amp three-phase meter sockets.
- (2) Line and load conductors must be identified at their terminations. Meter loops lacking properly identified conductors will not receive a CPS Energy meter. Customer assumes all responsibility for conductors that are improperly identified or terminated.
- (3) Meter sockets must have the line-side (PV Source) conductors connected to the line-side (top) of the meter socket. Load-side conductors must connect to load-side (bottom) of the meter socket (Refer to Figures 2000.2 and 2000.4).
- (4) Meter socket terminals are designed to accept either copper or aluminum conductors.
- (5) All wire ends must be wire brush cleaned. The wire brushed ends and terminals used with aluminum conductors shall have grit-filled joint compound applied to them before the terminal screws are torqued.
- (6) Customer must observe the terminal screw torque requirements.
- (7) Conductors formed within the socket's enclosure shall not rest on or press against other terminals.

Note: *In no case should Customer connect PV system in parallel with CPS Energy's source supply without first having a commissioning performed and written express consent of CPS Energy.*

(F) PV AC Meter Disconnect:

A disconnect furnished and installed by Customer is required on the load-side of inverters and before CPS Energy PV system metering equipment. The PV AC meter disconnect shall be located immediately adjacent to the PV system metering equipment and shall be readily accessible and capable of being locked in the open position (Refer to Figure 2000.2 and 2000.4).

Note: *An additional disconnect to isolate the PV meter will be required where the interconnection is made at a location remote from where the PV meter is to be located.*

(G) Labeling of Equipment:

Customer shall be responsible for all labeling of DG Facilities equipment as outlined in Figure 2000.6. Such labeling shall be in place at time of commissioning.

(H) Interconnection of PV System:

Interconnection of a PV system shall be in accordance with the NEC and other applicable codes and shall only be done on the load-side of Customer revenue metering equipment (Refer to Figures 2000.2 through 2000.5).

Raceways containing inverter output conductors shall be EMT for all above ground portions and shall not contain conduit bodies (LB's) or junction boxes unless specifically approved by CPS Energy's Electric Service and Metering Standards Section.

Exception: *Conduit underground shall be permitted to be PVC type. The portion of conduit extending above ground shall be permitted to be schedule 80 PVC provided it is supported securely and it does not extend more than 4 feet.*

- (1) Load-Side Interconnections shall be made on the load-side of the Customer's main service panel. A main breaker is required and shall be used in the bus ampere rating calculation to ensure the bus rating is not exceeded. Interconnections for residential installations shall be made at exterior panels.
- (2) Line-Side Interconnections shall be made in a junction box or auxiliary gutter ahead of the service disconnecting means. Junction box shall be suitable for the conditions, provided with locking provisions and be sized as per the NEC but not be less than 12 inches by 12 inches.

Note 1: *Conductors from junction box to PV AC Disconnect shall be treated as service-entrance conductors and shall be as short as possible; in no case shall the distance exceed 10 feet.*

(I) Rapid Shutdown of PV Systems:

Rapid shutdown shall be required in accordance with the NEC and shall be included in the design with proper labeling (Refer to Figures 2000.2 through 2000.6).

(J) Grounding of PV Systems:

Grounding shall be as permitted by the NEC and in accordance with Figures 2000.2 and 2000.4.

(K) PV System Conductors in Attic Spaces:

Where PV system DC conductors are to be installed in attic spaces, conductors shall be installed in approved metal raceways/conduits in accordance with the NEC and other applicable codes.

Where PV system AC conductors are to be installed in attic spaces, the conductors shall be installed in approved raceways/conduits with labels denoting PV AC conductors.

2006 Technical Information Required:

Customer's application, submitted materials, and drawings are reviewed by CPS Energy to identify and assist in resolution of any issues associated with the proposed DG Facilities interconnecting to the CPS Energy distribution system or terminating directly to Customer service equipment. At a minimum the following information is required for review:

- (1) Detailed operational one-line diagram for residential installations and three-line diagram for commercial installations.
- (2) Detailed site plan showing geographic orientation with location of existing and proposed service and metering equipment.
- (3) Meter loop drawing (elevation view) showing the proposed equipment layout.
- (4) Show all protective devices including rapid shut-down equipment and include as applicable size, rating, manufacturer, type, style, model, and settings.
- (5) Manufacturer specifications for inverters and solar panels.
- (6) Photos of the existing service to identify clearance issues and/or other issues that may need to be addressed as part of the DG installation.

Note 1: All sheet drawings shall be to scale in PDF format.

Note 2: For DG 25 kW and above or where specifically required by CPS Energy, sealed, and signed drawings will be required by a State of Texas licensed or registered engineer.

Note 3: Pre-existing DG installations shall be incorporated into the final design submittal and shall meet all current installation requirements. Systems with a pre-existing alternative power source shall be reflected on proposed one-line. Customer shall provide operational scheme with manual or automatic transfer switch.

2007 Commissioning of DG System:

Prior to connection of the DG Facilities to the Interconnection Facilities, CPS Energy will send a representative(s) to the DG site to inspect and perform acceptance tests on the DG Facilities to determine compliance with technical requirements and that all metering, telemetry, communications equipment, etc. associated with the DG Facilities is properly functioning and receiving and transmitting accurate information.

2008 Access to DG Site:

CPS Energy shall have reasonable access to DG sites at all times and shall provide advance notice to Customer of the need for CPS Energy presence at the respective DG site, except that no advance notice is necessary in the case of an emergency, in connection with the performance of CPS Energy obligations

imposed on it by this Agreement, or if necessary to meet CPS Energy's legal obligation to provide service to CPS Energy retail Customers.

2009 Operational Requirements for DG:

CPS Energy and the Customer share in the responsibility of having operational and maintenance of DG Facilities due to the special metering equipment required and the safety concerns with paralleling sources with CPS Energy's distribution system.

Failure by Customer to operate and maintain all wiring and apparatus associated with their DG Facilities in such condition or manner as not to endanger persons or property or to cause impairment of CPS Energy's distribution system may result in CPS Energy disconnecting the Customer from CPS Energy's distribution system.

FIGURE 2000.1
TYPICAL 120/240-VOLT, SINGLE-PHASE WHOLE HOUSE GENERATOR SYSTEM

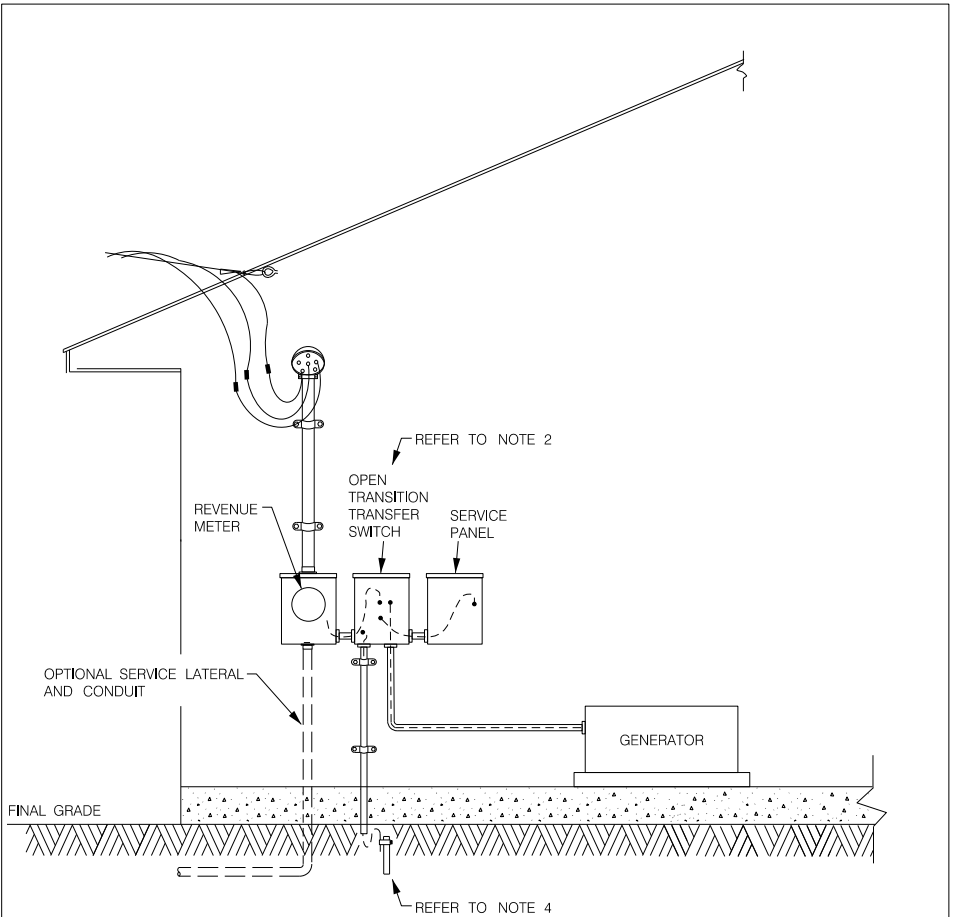

NOTES:

1. GENERATORS FOR WHOLE HOUSE BACK-UP MUST BE REVIEWED AND APPROVED BY ELECTRIC SERVICE AND METERING STANDARDS.
2. TRANSFER SWITCHES SHALL BE OPEN-TRANSITION (MAKE BEFORE BREAK) AND LISTED FOR USE AS SERVICE-ENTRANCE.
3. DG APPLICATION MUST BE COMPLETED AND SUBMITTED WITH ELECTRICAL DRAWINGS THAT INCLUDE, SITE PLAN, ELEVATION DRAWING AND ONE-LINE.
4. GROUNDING ELECTRODE SYSTEM TO BE INSTALLED IN ACCORDANCE WITH THE NATIONAL ELECTRICAL CODE AND SECTION 1700.
5. A FINAL COMMISSION MAY BE PREPARED AT CPS ENERGY'S DISCRETION.

FIGURE 2000.2
 TYPICAL PHOTOVOLTAIC (PV) SYSTEM
 120/240-VOLT SINGLE-PHASE THREE-WIRE DIAGRAM

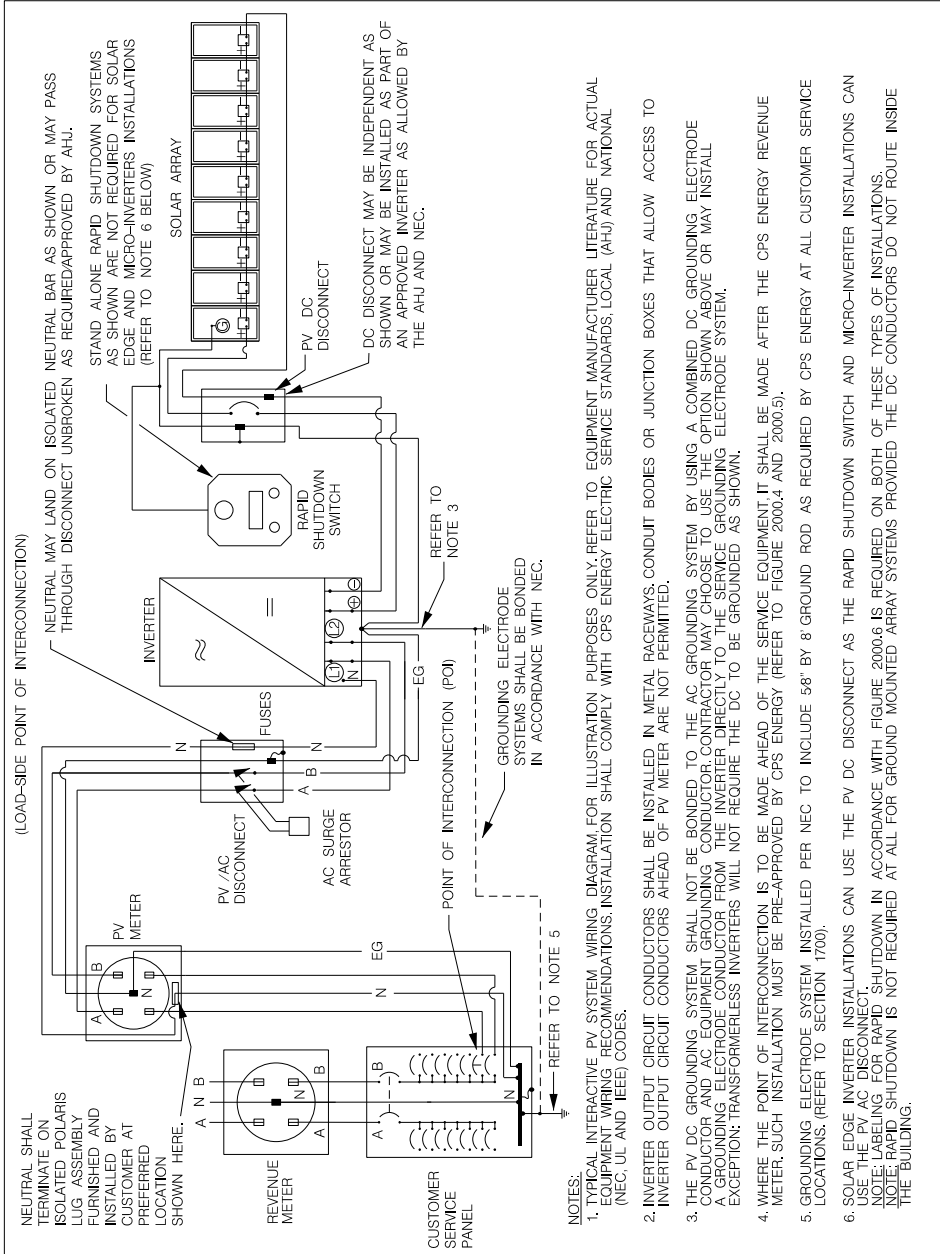
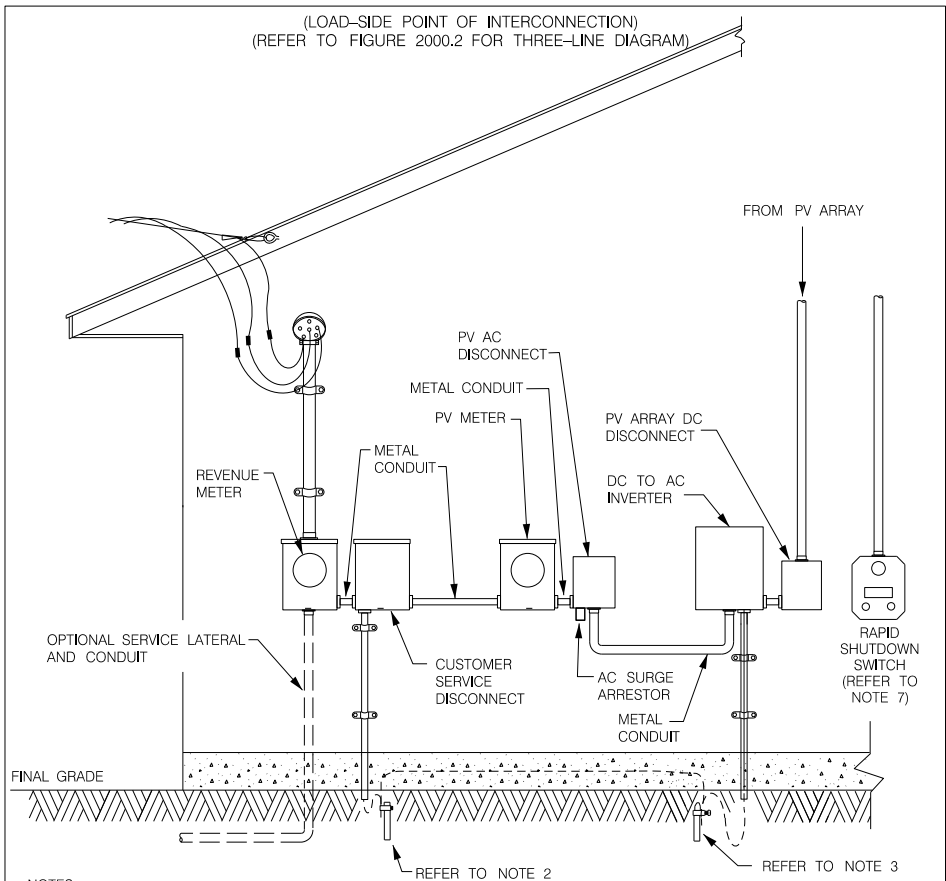

FIGURE 2000.3
TYPICAL 120/240-VOLT, SINGLE-PHASE PHOTOVOLTAIC (PV) SYSTEM



NOTES:

1. INVERTER OUTPUT CIRCUIT CONDUCTORS SHALL BE INSTALLED IN METAL RACEWAYS FROM INVERTER TO POINT OF INTERCONNECTION, CONDUIT BODIES OR JUNCTION BOXES ARE NOT PERMITTED FOR THAT PORTION OF CONDUCTORS AHEAD OF THE PV METER.
2. GROUNDING ELECTRODE SYSTEM INSTALLED AS PER NEC TO INCLUDE 5/8-INCH X 8-FOOT GROUND ROD AS REQUIRED BY CPS ENERGY AT ALL CUSTOMER SERVICE LOCATIONS (REFER TO SECTION 1700).
3. THE PV DC GROUNDING SYSTEM SHALL NOT BE BONDED TO THE AC GROUNDING SYSTEM BY USING A COMBINED DC GROUNDING ELECTRODE CONDUCTOR AND AC EQUIPMENT GROUNDING CONDUCTOR. CONTRACTOR MAY CHOOSE TO USE THE OPTION SHOWN ABOVE OR MAY INSTALL A GROUNDING ELECTRODE CONDUCTOR DIRECTLY FROM THE INVERTER GROUNDING ELECTRODE TERMINAL TO THE MAIN SERVICE GROUNDING ELECTRODE SYSTEM. EXCEPTION: TRANSFORMERLESS INVERTERS WILL NOT REQUIRE THE DC TO BE GROUNDING AS SHOWN.
4. THE PV AC DISCONNECT AND PV METER SHALL BE LOCATED IMMEDIATELY ADJACENT TO THE REVENUE METER.
5. LABELING AND IDENTIFICATION OF ALL PV RELATED EQUIPMENT SHALL BE DONE IN ACCORDANCE WITH THE NEC AND SECTION 2000 OF THESE STANDARDS (REFER TO FIGURE 2000.6).
6. WHERE THE POINT OF INTERCONNECTION IS TO BE MADE AHEAD OF THE SERVICE EQUIPMENT, IT SHALL BE MADE AFTER THE CPS ENERGY REVENUE METER. SUCH INSTALLATIONS MUST BE PRE-APPROVED. (REFER TO FIGURES 2000.4 AND 2000.5)
7. RAPID SHUTDOWN METHODS MAY VARY (PLEASE REFER TO FIGURE 2000.5)

FIGURE 2000.4
 TYPICAL PHOTOVOLTAIC (PV) SYSTEM
 120/240-VOLT SINGLE-PHASE THREE-WIRE DIAGRAM

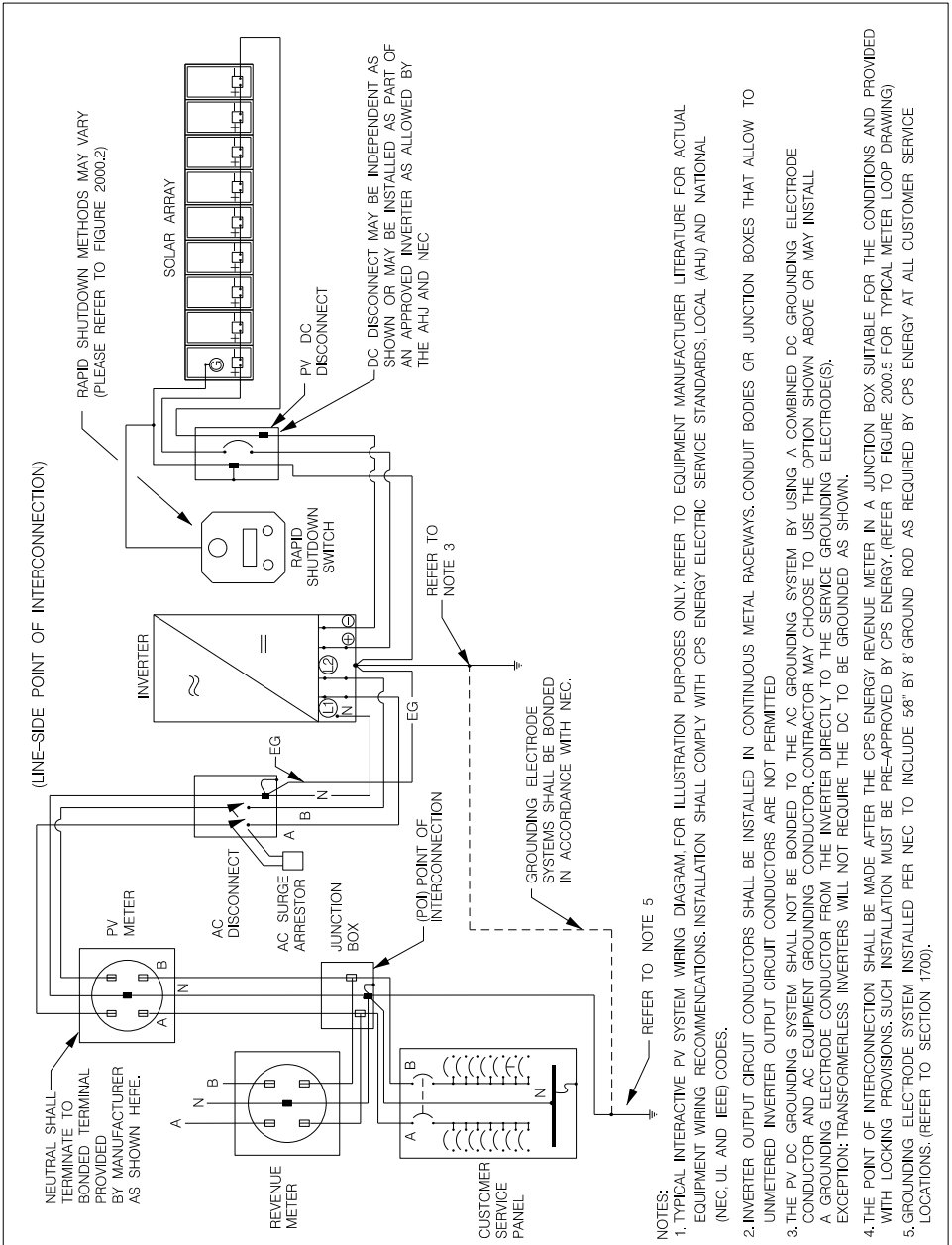

- NOTES:**
1. TYPICAL INTERACTIVE PV SYSTEM WIRING DIAGRAM FOR ILLUSTRATION PURPOSES ONLY. REFER TO EQUIPMENT MANUFACTURER LITERATURE FOR ACTUAL EQUIPMENT WIRING RECOMMENDATIONS. INSTALLATION SHALL COMPLY WITH CPS ENERGY ELECTRIC SERVICE STANDARDS, LOCAL (AHJ) AND NATIONAL (NEC, UL AND IEEE) CODES.
 2. INVERTER OUTPUT CIRCUIT CONDUCTORS SHALL BE INSTALLED IN CONTINUOUS METAL RACEWAYS, CONDUIT BODIES OR JUNCTION BOXES THAT ALLOW TO UNMETERED INVERTER OUTPUT CIRCUIT CONDUCTORS ARE NOT PERMITTED.
 3. THE PV DC GROUNDING SYSTEM SHALL NOT BE BONDED TO THE AC GROUNDING SYSTEM BY USING A COMBINED DC GROUNDING ELECTRODE CONDUCTOR AND AC EQUIPMENT GROUNDING CONDUCTOR. CONTRACTOR MAY CHOOSE TO USE THE OPTION SHOWN ABOVE OR MAY INSTALL A GROUNDING ELECTRODE CONDUCTOR FROM THE INVERTER DIRECTLY TO THE SERVICE GROUNDING ELECTRODE(S). EXCEPTION: TRANSFORMERLESS INVERTERS WILL NOT REQUIRE THE DC TO BE GROUNDING AS SHOWN.
 4. THE POINT OF INTERCONNECTION SHALL BE MADE AFTER THE CPS ENERGY REVENUE METER IN A JUNCTION BOX SUITABLE FOR THE CONDITIONS AND PROVIDED WITH LOCKING PROVISIONS. SUCH INSTALLATION MUST BE PRE-APPROVED BY CPS ENERGY. (REFER TO FIGURE 2000.5 FOR TYPICAL METER LOOP DRAWING)
 5. GROUNDING ELECTRODE SYSTEM INSTALLED PER NEC TO INCLUDE 5/8" BY 8' GROUND ROD AS REQUIRED BY CPS ENERGY AT ALL CUSTOMER SERVICE LOCATIONS. (REFER TO SECTION 17000).

FIGURE 2000.5
 TYPICAL 120/240-VOLT, SINGLE-PHASE PHOTOVOLTAIC (PV) SYSTEM

(LINE-SIDE POINT OF INTERCONNECTION)
 (REFER TO FIGURE 2000.4 FOR THREE-LINE DIAGRAM).

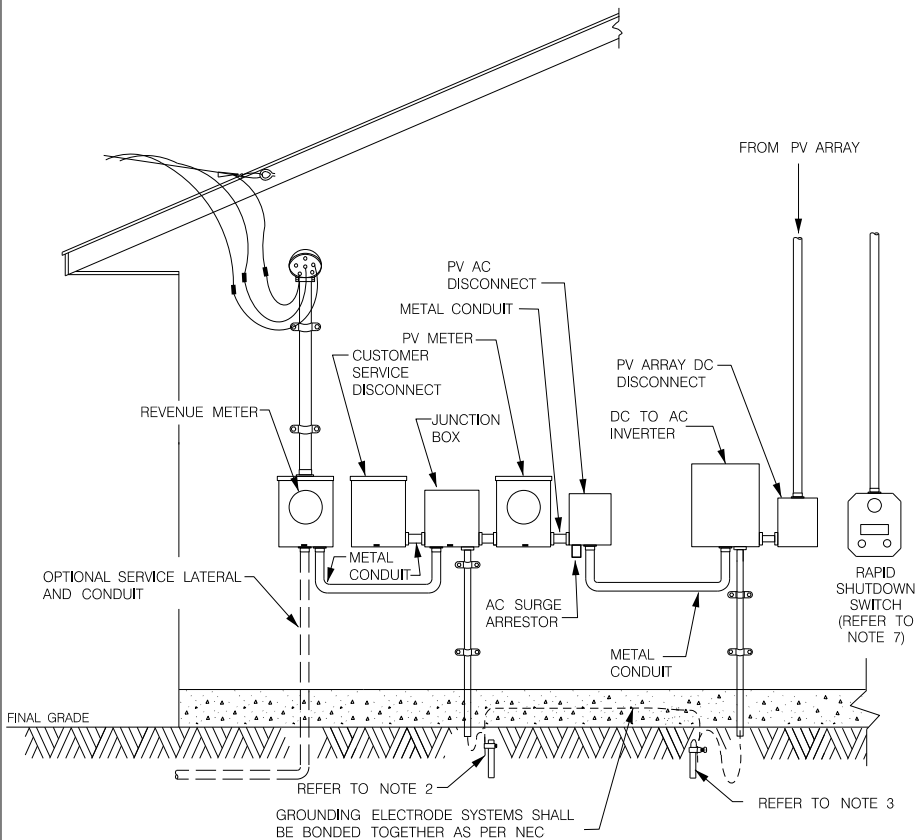

NOTES:

1. INVERTER OUTPUT CIRCUIT CONDUCTORS SHALL BE INSTALLED IN METAL RACEWAYS FROM INVERTER TO POINT OF INTERCONNECTION, CONDUIT BODIES OR JUNCTION BOXES ARE NOT PERMITTED FOR THAT PORTION OF CONDUCTORS AHEAD OF THE PV METER.
2. GROUNDING ELECTRODE SYSTEM INSTALLED AS PER NEC TO INCLUDE 5/8-INCH X 8-FOOT GROUND ROD AS REQUIRED BY CPS ENERGY AT ALL CUSTOMER SERVICE LOCATIONS (REFER TO SECTION 1700).
3. THE PV DC GROUNDING SYSTEM SHALL NOT BE BONDED TO THE AC GROUNDING SYSTEM BY USING A COMBINED DC GROUNDING ELECTRODE CONDUCTOR AND AC EQUIPMENT GROUNDING CONDUCTOR. CONTRACTOR MAY CHOOSE TO USE THE OPTION SHOWN ABOVE OR MAY INSTALL A GROUNDING ELECTRODE CONDUCTOR DIRECTLY FROM THE INVERTER GROUNDING ELECTRODE TERMINAL TO THE MAIN SERVICE GROUNDING ELECTRODE SYSTEM. EXCEPTION: TRANSFORMERLESS INVERTERS WILL NOT REQUIRE THE DC TO BE GROUND AS SHOWN.
4. THE PV AC SERVICE DISCONNECT AND PV METER SHALL BE LOCATED IMMEDIATELY ADJACENT TO THE REVENUE METER.
5. LABELING AND IDENTIFICATION OF ALL PV RELATED EQUIPMENT SHALL BE DONE IN ACCORDANCE WITH THE NEC AND SECTION 2000 OF THESE STANDARDS.
6. THE POINT OF INTERCONNECTION SHALL BE MADE AFTER THE REVENUE METER IN A JUNCTION BOX SUITABLE FOR THE CONDITIONS AND PROVIDED WITH LOCKING PROVISIONS. (REFER TO FIGURE 2000.4).
7. RAPID SHUTDOWN METHODS MAY VARY (PLEASE REFER TO FIGURE 2000.2)

FIGURE 2000.6
 LABELING REQUIREMENTS FOR TYPICAL PHOTOVOLTAIC (PV) SYSTEMS

LABELS LISTED BELOW REPRESENT BASIC LABELING ASSOCIATED WITH A TYPICAL PHOTOVOLTAIC (PV) SYSTEM INSTALLATION AND IS NOT INTENDED TO INCLUDE ALL LABELING WHICH MAY BE REQUIRED BY THE NEC AND AHJ.

PV DC DISCONNECT

(2017 NEC ARTICLES: 690.53)

PV SYSTEM DC DISCONNECT

MAXIMUM VOLTAGE: XXX
 MAXIMUM CIRCUIT CURRENT: XXX
 MAXIMUM RATED OUTPUT CURRENT OF THE CHARGE CONTROLLER OR DC TO DC CONVERTER (IF INSTALLED): XXX

PV AC DISCONNECT

(2017 NEC ARTICLE 690.13 (B))

PV SYSTEM AC DISCONNECT

RATED AC OUTPUT CURRENT: XXX
 NOMINAL OPERATING AC VOLTAGE: XXX

PV METER SOCKET

PV METER

CPS ENERGY REVENUE METER SOCKET:

REVENUE METER

NOTE: PLACARD BELOW REQUIRED ON BOTH REVENUE AND PV METER SOCKETS WHERE METERS HAVE BEEN APPROVED TO BE REMOTE FROM ONE ANOTHER.



INVERTER OUTPUT CONNECTION:

(2017 NEC ARTICLE 705.12 (B) (2) (3) (b))

WARNING: INVERTER OUTPUT CONNECTION DO NOT RELOCATE THIS OVERCURRENT DEVICE

RACEWAYS/ENCLOSURES CONTAINING DC CONDUCTORS:

WARNING: PHOTOVOLTAIC POWER SOURCE

NOTES:

- 1- LABELING SHALL BE PERMANENTLY AFFIXED AND SUITABLE FOR THE ENVIRONMENT AND IN ACCORDANCE WITH 2017 NEC, ARTICLE 110.21 (B).
- 2- PV METER SHALL BE LOCATED ADJACENT TO THE REVENUE METER UNLESS PRE-APPROVED BY CPS ENERGY TO BE LOCATED REMOTELY DUE TO SPECIAL CIRCUMSTANCES.

CUSTOMER SERVICE PANEL

DIRECTORY/PLAQUE (2017 NEC ARTICLE 705.10)

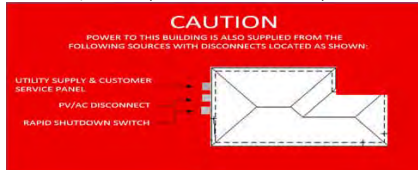

PLACED ON SERVICE PANEL AND ON SYSTEM DISCONNECTS FOR OTHER ELECTRIC POWER PRODUCTION SOURCES WHEN NOT GROUPED

RAPID SHUTDOWN PLACARD (2017 NEC ARTICLE 690.56)

SOLAR PV SYSTEM EQUIPPED WITH RAPID SHUTDOWN

TURN RAPID SHUTDOWN SWITCH TO THE "OFF" POSITION TO SHUTDOWN PV SYSTEM AND REDUCE SHOCK HAZARD IN ARRAY

PLACED ON SERVICE PANEL FOR SYSTEMS THAT SHUTDOWN THE ARRAY AND CONDUCTORS LEAVING ARRAY.

RAPID SHUTDOWN PLACARD (2017 NEC ARTICLE 690.56)

SOLAR PV SYSTEM EQUIPPED WITH RAPID SHUTDOWN

TURN RAPID SHUTDOWN SWITCH TO THE "OFF" POSITION, TO SHUTDOWN CONDUCTORS OUTSIDE THE ARRAY. CONDUCTORS WITHIN ARRAY REMAIN ENERGIZED IN SUNLIGHT

PLACED ON SERVICE PANEL FOR SYSTEMS THAT ONLY SHUT DOWN CONDUCTORS WITHIN 10 FT OF LEAVING THE ARRAY.

RAPID SHUTDOWN SWITCH:

(2017 NEC ARTICLE 690.12 (C))

RAPID SHUTDOWN SWITCH FOR SOLAR PV SYSTEM

PLACED ON INVERTER DC DISCONNECT SWITCH WHEN SWITCH SHUTS DOWN THE ARRAY AND CONDUCTORS LEAVING ARRAY

PV/AC AGGREGATE PANEL:

PV/AC AGGREGATE PANEL: DO NOT REMOVE, ADD OR RELOCATE ANY CIRCUITS FROM THIS PANEL